

**NOISE MEASUREMENTS IN WINDY
CONDITIONS**

ETSU W/13/00386/REP

Contractor

**ISVR Consultancy Services,
University of Southampton**

Prepared by

R A Davis
Dr M C Lower

The work described in this report was carried out under contract as part of the New and Renewable Energy Programme, managed by the Energy Technology Support Unit (ETSU) on behalf of the Department of Trade and Industry. The views and judgements expressed in this report are those of the contractor and do not necessarily reflect those of ETSU or the Department of Trade and Industry.

Summary

1	Introduction	1
2	Control Windscreens	3
3	Design and Fabrication of Test Windscreens	4
4	Measurement of Free Field Response Corrections	6
5	Preliminary Measurements and Development of Study Methodology	7
	5.1 General	7
	5.2 Preliminary Measurements	7
	5.3 Measurement Results	8
	5.4 Implications for Study Methodology	9
6	Exploratory Measurements in a Wind Tunnel	11
	6.1 Measurement and Analysis System	11
	6.2 Test Windscreens	12
	6.3 Test Procedure and Observations	12
	6.4 Results	12
7	Further Wind Tunnel Tests	14
	7.1 Test Results	14
	7.2 Conclusions from Wind Tunnel Measurements	15
	7.2.1 Configuration	15
	7.2.2 Dimensions	15
	7.2.3 Foam Grade	16
	7.2.4 Preferred Configuration	16
8	Outdoor Measurements	17
	8.1 Location	17
	8.2 Procedure	17
	8.3 Test Windscreens	17
	8.4 Analysis of Recordings	18
	8.5 Results	18
	8.6 Effect of Windscreens on L_{10} and L_{90} Values	19
	8.7 Observations	19
9	Overall Conclusions from Wind Tunnel and Outdoor Measurements	20
10	Effect of Water Absorption	21

Contents/Contd	Page	
11	General Discussion - Measurements in Windy Conditions	23
	11.1 Characterisation of Windscreen Performance	23
	11.2 Practical Considerations	24
12	Proposals for Further Development	25
Tables	1 - 5	
Figures	1 - 58	
Appendix A	Windscreens and Wind Noise in Microphones: A Literature Review	
Appendix B	Information on Standard Microphone Windscreens (Brüel and Kjær)	
Appendix C	One-third Octave Band Spectra Showing Effect of Windscreens on Free-field Frequency Response of 4155 Microphone (90° incidence)	

Summary

The assessment of noise from wind farms requires noise measurements to be made in mean wind speeds of up to 10 metres per second, or higher. Existing commercially-available windscreens for instrumentation microphones provide inadequate control of wind noise at such high wind speeds.

A study was carried out to develop and test a microphone windscreen which would have significantly better performance than the available designs in reducing wind noise, but which would be relatively simple to construct, suitable for use with standard noise measurement microphones without causing inaccuracy in measurements, and sufficiently inexpensive to gain wide acceptance.

Following a review of the published literature three basic designs emerged. These were

- a 'hollow' single layer of open-cell foam mounted on a frame surrounding the microphone
- a two-layer design with a 'hollow' foam layer as above surrounding a conventional commercial windscreen
- a 'solid' open-cell foam windscreen

Practical prototype windscreens of each of the above types were constructed, with sizes varying from 200 mm to 400 mm diameter, and with different grades of foam from 10 to 80 pores per inch.

The acoustic insertion loss of each prototype windscreen was first measured. Windscreens which had an insertion loss within the range ± 1 dB in any one-third octave band from 25 Hz to 10 kHz were classed as satisfactory.

A range of windscreens was then tested in a wind tunnel side by side with a commercial 'control' windscreen. The level of the wind noise at the test windscreen was compared with the noise at the control windscreen. In smooth flow there was little differences between the test prototypes and the control windscreen. When turbulence was created by placing a coarse metal grid upstream of the windscreens the prototype windscreens showed large reductions in wind noise at low frequencies whereas the control windscreen did not. The acoustic noise of the wind tunnel motor and fan prevented measurements of wind noise at middle frequencies, but the prototype windscreens could be compared at low frequencies and the most promising selected for further trials at an outdoor windy site.

Noise and wind speed measurements were made at an exposed outdoor site in winds of typically 3 to 8 m/s with an average of about 6 m/s and gusts above 12 m/s. Two prototype windscreens gave similar performance and were considered to be the

optimum. These were both two-layer designs, both with an outer layer of 45 pores per inch foam, and both enclosing a foam ball as the inner screen. The two prototypes differed in their diameter. One was a 200 mm diameter, the other a 300 mm diameter cylinder. The 300 mm diameter windscreen was slightly better than the 200 mm windscreen at reducing wind noise at low frequencies, but slightly poorer at high frequencies. Both prototype windscreens reduced wind noise by approximately 15 dB in some one-third octave bands below 250 Hz compared to the control windscreen, and both reduced the A-weighted level by approximately 6 dB.

It is recommended that one or more of the prototype windscreens, with minor modifications, be made available to interested potential users for further evaluation in field trials, preferably by direct comparison with standard windscreens.

I Introduction

This report describes work commissioned by ETSU, under Agreement No. W/13/00386/00/00, to devise and develop an 'improved' microphone windscreen for noise measurements outdoors. Outdoor noise measurements in the presence of wind are likely to be affected by pressure fluctuations already present within the turbulent air flow or generated by the flow of air over the microphone. Unless complex signal processing techniques are employed, the measurement system cannot discriminate between flow-induced pressure fluctuations (termed in this report 'wind noise') and those arising from the acoustic source(s) being measured. Windscreens to reduce wind noise are commercially available, but these devices are effective only at relatively low wind speeds.

There is a specific need to reduce the measurement uncertainty associated with outdoor noise measurements made in windy conditions, particularly in the range of mean wind speeds between 3 and 10 m/s, for the measurement of noise from wind turbines, and for measuring background noise levels in the vicinity of proposed wind farms.

The background to this study, and the outcome of a literature search on the design of microphone windscreens, were described in a preliminary report, the main part of which is reprinted here as Appendix A.

Three fundamental requirements have been identified for the 'improved' windscreen design:

- The wind noise levels shall be significantly reduced compared with commercial windscreens. The notional objective is to achieve a 10 dB(A) reduction in wind-induced noise in a mean wind speed of 10 m/s.
- The improved windscreen shall be of a simple, robust design, capable of being constructed from scratch or from a kit of parts using readily-available materials, such that consistent performance can be achieved.
- The acoustic performance of the microphone shall not be significantly impaired by the presence of the windscreen in any flow conditions.

From the literature review, three basic windscreen configurations emerged as potential candidates: hollow single-layer, hollow two-layer, and solid. These terms are explained in Section 3. In all cases, the design principle is to enclose the microphone within an envelope of porous material. The main design variables are the flow resistance of the porous layer(s), the number of layers, and the disposition of the layer(s) relative to the microphone.

The basic experimental methodology adopted in this study was to carry out side by side comparisons of the outputs from two nominally-identical microphones placed close together in an air stream. Generally, one microphone was fitted with the 'test' windscreen, the other being fitted with the 'control' or reference windscreen. These measurements were made in a low speed wind tunnel and outdoors in wind. The results have been used to select the optimum windscreen configuration.

A progress report was issued in July 1995, which covered the design and fabrication of the test windscreens, measurement of the effects of the windscreens on the microphone frequency response, and the results of preliminary tests. The contents of the progress report have been incorporated, in abbreviated form where appropriate, into this final report.

2 Control Windscreens

For the purposes of this study, two standard commercially-available windscreens have been used as control or reference windscreens for the evaluation of test windscreens. These were types manufactured by Brüel and Kjær (B&K); other manufacturers of noise measurement equipment offer similar devices. The control windscreens were:

- Type UA 0237 - A 'solid' 90 mm diameter open-cell foam ball, with a radial passage to accommodate the microphone assembly.
- Type UA 0570 - A cylindrical hollow foam screen, carried on a wire frame which is in turn supported from a plastic bush clamped to the microphone assembly. The wire frame incorporates 'bird spikes' to deter birds when the system is left unattended. This windscreen is marketed as an Outdoor Microphone System, and is supplied with a conical Rain Guard (Type UA 0393) which replaces the normal microphone grid and prevents the microphone diaphragm becoming wet during rain.

These windscreens are illustrated in Figures 1 and 2. Copies of the manufacturer's literature are attached in Appendix 1.

Measurements at various stages of the study showed that in terms of the reduction of wind noise, the two control windscreens are effectively interchangeable; within the limits of measurement uncertainty, their performance is the same. For convenience, because it can be fitted without removing the microphone grid, the UA 0237 foam ball windscreen was used as the control for the outdoor tests, whilst the UA 0570/0393 was used for the wind tunnel tests.

As described in Section 3, the control windscreen was also used as the inner component of the two-layer test windscreens. Again, the UA 0237 and UA 0570/0393 are interchangeable in this configuration. Most users would prefer the UA 0237, on grounds of simplicity and lower cost. However, for unattended measurements when rainfall might be expected, the UA 0393/0570 might be preferred because of the better protection against rain. The test windscreens were not designed to provide additional weather protection. Generally, the UA 0237 was used as the inner windscreen in two-layer test windscreens.

3 Design and Fabrication of Test Windscreens

The test windscreens and details of their construction are illustrated in Figures 3 - 9.

The windscreens have been designed to enclose a ½" condenser microphone (Brüel & Kjør 4155) and associated pre-amplifier, which is connected via an extension cable to a remote sound level meter or data logger. The microphone is mounted with the diaphragm in a horizontal plane. For simplicity of construction, the test windscreens are cylindrical.

Windscreens are constructed on a light frame made of welding rod, joined by silver-soldering. Frames are of 200, 300 and 400 mm diameter, all being approximately 400 mm high. It was concluded that windscreens larger than 400 mm diameter would be impracticable for general use, and would impose very high windage loads on the supporting tripod or stand. The outer porous covering is formed as a sleeve, joined down the seam with impact adhesive, which can be slid on to the outside of the frame. The top and bottom of hollow windscreens are foam discs, secured by sharpened pins (made from welding rod) passed through the outer sleeve.

Solid windscreens are made on the same wire frames, in 200 and 300 mm diameters only, by filling the outer sleeve with stacked foam discs which have central holes as required to accommodate the microphone, pre-amplifier and cable.

The screens are designed to be mounted directly onto the thread of a standard photographic tripod, widely used for mounting sound level meters and microphones for field measurements. The vertical members of the wire frames are pulled in at the bottom and fixed by grub screws into a circular aluminium-alloy mounting plate. This is clamped to the top of the tripod plate by the microphone holder: for this study, the microphone holder is fabricated specifically to mount the Brüel & Kjør ZC 0020, which is the detachable 'front end' of the Brüel & Kjør 2230/2231 sound level meter. The dimensions are such that the microphone is held at approximately mid-height within the screen. Minor modifications would be required to mount different microphone/pre-amplifier combinations.

Selection of the porous envelope material is influenced by cost, availability, consistency of manufacture (in terms of flow resistance), ease of fabrication, and durability. These requirements are satisfied by reticulated polyester foam, manufactured primarily for air filtration purposes. The commercial control windscreens are made of this material. Suitable foam is available in the UK from Declon Limited, in a range of thicknesses and flow resistance grades. These grades are classified by the supplier in terms of the nominal number of pores per linear inch (10, 20, 30, 45, 60 and 80 ppi). These designations are adopted in this report. For the purposes of this study, several sheets of each foam grade, of 20 mm thickness, were purchased.

Each windscreen size can be built in the six foam porosity grades. The hollow windscreens can be used alone, or with the Brüel & Kjær UA 0237 or UA 0570 fitted to the microphone to create a two-layer screen.

The full range of test windscreens is shown in Table 1.

4 Measurement of Free-Field Response Corrections

The acoustic performance of the windscreens in still air has been determined by measuring the free-field insertion loss, relative to the unscreened microphone, for sound at 90° (or grazing) incidence. These measurements were made in the large anechoic chamber at ISVR. The test microphone was positioned approximately 3.0 metres from a loudspeaker emitting 'pink' noise, and at the same height as the loudspeaker drive unit. The insertion losses were measured in one-third octave bands from 25 Hz - 10 kHz using a B&K Type 2133 frequency analyser. The measured insertion losses for all the windscreens are shown graphically in Appendix C.

It is evident that some windscreens, particularly the solid configurations, present significant attenuation at higher frequencies. Since the attenuation is frequency-dependent, it is not possible to correct site noise measurements for windscreen effects unless the frequency spectrum is measured. Some windscreen configurations can therefore be eliminated from the study at this stage, on the grounds that their attenuation characteristics would lead to unacceptable uncertainties in the measurement of A-weighted sound levels.

It has been agreed with ETSU that the acoustic effect of a windscreen can be ignored, for practical purposes, if the free-field insertion loss does not exceed 1.0 dB over the frequency range covered by the 31.5 Hz to 8 kHz octave bands. However, since A-weighted levels of wind turbine noise, or background noise in rural areas, are rarely influenced by levels in the octave bands centred at 31.5 Hz and 8 kHz bands, it may be justifiable to relax the limit to 3 dB in these bands. The test windscreens can therefore be classified as 'satisfactory', 'marginal', or 'unsatisfactory' on the basis of the data in Appendix 2. Classification of windscreens is shown in Table 1.

The effect of water absorption (such as might occur in rain) on the insertion loss of windscreens is discussed in Section 10.

On the basis of these measurements, windscreen configurations shown as 'unsatisfactory' were excluded from further evaluation. Experimental work was concentrated on the 'satisfactory' windscreens, although 'marginal' windscreens were included where test results indicate that windscreens in this category were likely to be significantly more effective in reducing wind-induced noise.

5 Preliminary Measurements and Development of Study Methodology

5.1 General

The test programme was directed towards identifying the windscreen configuration which is most effective in reducing wind noise. Initially, it was intended to carry out 'side-by-side' measurements of the output from two identical microphones fitted with the 'test' and 'control' windscreens, with the microphones located close together on outdoor sites where background noise levels are low, during windy weather. If it is assumed that the test and control microphone/windscreen combinations are exposed to the same acoustic and air flow conditions, an improvement in test windscreen performance over the control is then evident as a lower measured sound pressure level from the 'test' system. The performance of the test windscreens would be rank-ordered from the 'test vs control' measurements. Final identification of the optimum configuration would be performed by side-by-side testing of candidate test windscreens.

5.2 Preliminary Measurements

Preliminary outdoor measurements were made during January 1995 to evaluate measurement and analysis procedures. The test location, in a country park (Farley Mount) near Winchester, was on open ground and remote from sources of background noise except for occasional passing vehicles and walkers.

This study used two nominally identical UA 0237 windscreens (the control windscreens) and Type 4155 microphones. The microphones were each mounted on the preamplifier which was connected via a microphone extension lead to B&K Type 2230 sound level meter. The microphones and preamplifiers were mounted on tripods approximately 1.2 metres above the ground and approximately 2 metres apart. The signal output from each meter was recorded on a Sony TCD-D10 two-channel portable digital tape recorder. The systems were calibrated before and after use with a B&K Type 4230 calibrator, and the calibration tones were recorded onto the tape.

Recordings were made of the ambient noise for a duration of about 40 minutes. During this period, the typical wind speeds (as measured on a hand-held rotating vane anemometer) varied between 3 and 8 m/s.

For analysis, periods of the recording were selected which were free from noise 'events' such as passing cars, and which contained clearly-audible wind noise. Wind noise is clearly detectable, by the characteristic 'buffeting', when recordings are monitored using a loudspeaker or headphones). The outputs from both channels were replayed through a B&K Type 2133 dual channel analyser to measure the one-third octave band spectrum, the overall unweighted level and the A-weighted level of the wind noise of each channel simultaneously. Initially the analyser was set to output

the spectra averaged over one second periods ($L_{eq,1s}$ band levels). Following this analysis and a critical audition of the tape recording, the analysis was subsequently repeated with a five-second averaging period ($L_{eq,5s}$ band levels). Frequency spectra from the analyser were output on diskette and read into Excel for Windows spreadsheets for analysis and plotting.

5.3 Measurement Results

Figure 10 shows the noise spectra recorded from the two microphones (identified as channels A and B), averaged over a period of about 8 minutes. Although very similar, the spectra are not identical.

Figure 11 shows typical time histories, time-synchronised, of the overall unweighted noise levels measured by the two microphones; the averaging time is 1 second. The 'excursions' above the minimum level of approximately 60 dB can be assumed to be caused by the effects of wind on the microphone. Figure 12 is an expanded version of part of Figure 11, covering a shorter time period. Figure 13 covers the same time period as Figure 5.2, but shows the **difference** in level between the noise at the two microphones, on the basis of one-second averaging times. It is evident from these time histories, and from listening to the tape through stereo headphones, that noise 'bursts' resulting from wind gusts did not necessarily occur simultaneously at both microphones, and sometimes a gust affecting one microphone 'missed' the second. This was a rather surprising result: it was expected that steady and unsteady wind speed components would be well-correlated within the microphone-to-microphone distance of 2 metres.

Figure 14 shows the overall (unweighted) sound pressure level measured by the two microphones, plotted against each other. Each data point represents the noise from the same one-second period measured at the two microphones. The correlation coefficient, r , is 0.93 with 471 datapoints. The slope of the line is not 1.0, but 0.90 (with a lower 95% confidence limit 0.87 and an upper limit of 0.94). There is also a wide scatter in the data.

Figure 15 shows the overall level from one microphone plotted against the level from the other, as on Figure 14, but with an averaging time of 5 seconds. Compared with the plot of 1 second averaged data, the scatter is less and the correlation coefficient is higher, at 0.97. If the 5 second averaged time histories are plotted (Figure 16), the differences between microphones are significantly smoothed. This is confirmed by the plot of the differences between microphones with time on Figure 17, which can be compared with Figure 13 which shows the same information for 1 second averaged data. It was concluded that 5 seconds is an appropriate averaging time for comparing noise spectra measured outdoors.

Figures 10, 14 and 15 and the regression analysis show that, in addition to the differences between microphone outputs over each averaging period (one or five seconds), illustrate by the scatter about a mean line, there was a systematic difference in the noise recorded at the two microphones. This is also shown by the spectral differences on Figure 10. The two systems were nominally identical. Differences could arise through different windscreen characteristics, or through a systematic difference between wind conditions at the two microphone positions. The latter effect could be reduced by placing the microphones closer together, but this was considered undesirable because of the possibility of mutual interference.

5.4 Implications for Study Methodology

As stated above, it was originally envisaged that 'side-by-side' tests of a large number of windscreen configurations would be made over a range of wind speeds at a number of outdoor sites with low background noise levels. This approach was re-evaluated in early 1995, in the light of the pilot study and of subsequent experience in attempting to carry out further outdoor measurements.

Suitable weather conditions (moderate to fresh winds, no rain) were rarely encountered in early 1995, or were not reliably forecasted. There are also practical difficulties in mobilising staff, necessarily at short notice, on the basis of a weather forecast. It was concluded that it was not practicable to attempt to gather 'side-by-side' site data for a large number of windscreens over a wide range of wind speeds at several sites within a reasonable timescale.

As discussed in 5.2, the level and frequency spectrum of wind-induced noise is strongly dependent on the turbulence in the incoming air flow. Longer-term variations in wind speed may occur during a noise measurement interval. These airflow parameters are not controlled. Obtaining test data for each windscreen over the same range of steady and unsteady air flow conditions is unlikely to be achievable.

The pilot study demonstrated that it would be desirable to compare microphone outputs using averaging times of at least five seconds. Using longer averaging times reduces the number of data points available to correlate wind noise with mean wind speed, and requires extended measurement times. It is also desirable to exchange test and control windscreen positions halfway through the measurement period (if not more frequently), to balance out the influence of any systematic difference between acoustic or wind pressures affecting the two microphones. This also extends measurement times.

To overcome these difficulties, consideration was given to other methods of ranking the performance of windscreens in controlled air flow conditions, with the objective of reducing the number of configurations which would be tested outdoors. A possibility

which was considered was to carry out initial measurements in the discharge flow from a small wind tunnel. This was not pursued. Preliminary measurements indicated that consistent results could not be achieved because the discharge was not large enough to present uniform airflow over the surface of the larger screens.

Exploratory tests were then carried out in the 7' x 5' (2.1 x 1.5m) wind tunnel operated by the Department of Aeronautics at Southampton. This wind tunnel provides the facility to accurately control wind speed in the working section, and to create controlled turbulence by the installation of grids of various coarseness upstream of the working section. The limitation (as discussed later) is the relatively high level of mechanical and aerodynamic noise from the tunnel drive motor and fan, which exceeds flow-induced noise over a significant frequency range. However, wind tunnel measurements presented a possible means of rank-ordering the windscreens, at least provisionally, in order of effectiveness. Outdoor measurements would be required, to validate the ranking order and to optimise the design, but it was anticipated that these would be of much-reduced scope. The results of these exploratory tests, and of a further structured series of wind-tunnel tests, are described in Sections 6 and 7.

6 Exploratory Measurements in a Wind Tunnel

The objective of these exploratory measurements was to determine whether wind tunnel testing could generate useful data on the comparative performance of different windscreens. Tests were carried out on 300 mm windscreens of the three basic configurations.

6.1 Measurement and Analysis System

The measurement and analysis system for these and all subsequent wind tunnel and outdoor measurements is shown schematically in Figure 18.

The main features are as follows:

- The two B&K 4155 microphones and the associated pre-amplifiers were mounted side by side, pointing vertically such that the diaphragms were horizontal, with the line between microphones at 90° to the air flow direction. The pair of windscreens to be compared were fitted to the two microphones.
- The microphone/pre-amplifier outputs were taken to B&K 2230 sound level meters via extension cables. The meter ac outputs were recorded on two 2-channel Sony TCD-D10 portable digital Tape (DAT) recorders. The real-time clocks in the recorders were synchronised.
- Measurement and recording systems were calibrated before the tests against reference systems held by ISVR; the calibration of the reference systems is traceable to national standards. Routine calibrations were carried out using a B&K 4231 Electronic Calibrator.
- Wind speed was measured using a Vector Instruments type A100 rotating cup anemometer. This device produces a dc output proportional to wind speed. A conditioning unit was developed to provide a 1 kHz square wave output, amplitude modulated by the dc signal from the anemometer, to enable wind speed data to be reliably recorded on the DAT recorders, in parallel with noise data.
- Microphone and anemometer outputs were analysed into one-third octave frequency bands using a B&K 2133 dual channel real-time analyser. This analyser permits on-screen comparison of measured or stored spectra to be performed. Data from the analyser was exported to spreadsheet (Microsoft Excel) for further manipulation.

6.2 Test Windscreens

The windscreens tested are given in Table 2.

6.3 Test Procedure and Observations

The microphones were mounted on tripods 1200 mm apart, at mid-height in the working section, with the anemometer between, as shown in Figure 19. At this stage, the anemometer was installed so it could be tested and calibrated prior to outdoor measurements. Velocities in the tunnel were measured using the calibrated pitot-static tube in the working section.

Measurements were made at air speeds of 2.5, 5, 7.5, 10 and 12.5 m/s. The output from the anemometer was recorded to check the calibration and linearity of this device. At various stages, test and control windscreens were exchanged to confirm that measurements were not affected by any non-uniformity in flow conditions or in the noise field in the working section.

Tripods were restrained by light rope fixed to iron weights. The windscreens showed some deflection at 12.5 m/s air speed, indicating that some stiffening, or guy lines fixed to the windscreen frames, may be necessary to avoid damage outdoors in gusty conditions.

Measurements were initially made in nominally smooth flow. Turbulence was then introduced, in an ad hoc manner, by the introduction of a person standing approximately 2 metres upstream of the microphones with arms outstretched. It was confirmed, by exchanging the positions of test and control microphones, that similar flow conditions were presented to each microphone.

6.4 Results

Results for an air speed of 10 m/s are shown in Figures 20 to 32.

Figures 20 and 21 compare the noise level measured using the Brüel & Kjær UA 0237 and UA 0570 windscreens with levels derived from manufacturer's data for wind-induced noise. These data were calculated from the '40 km/h' data, corrected to 10 m/s (36 km/h) by subtracting 2.3 dB, assuming sound power to be proportional to V^3 , where V is the wind speed.

Figures 22 - 32 compare one-third octave spectra of noise measured at the test and control microphones in smooth and turbulent flow.

The following conclusions can be drawn:

- In smooth flow, measured noise levels in the tunnel are dominated by background noise from the tunnel except at low and high frequencies, where wind-induced noise is a contributory factor. (Figures 20 and 21). In these conditions, the test windscreens demonstrate only minor performance differences relative to the controls.
- The 30 ppi hollow screen, in single- or two-layer configuration, produces the greatest noise reduction of the screens tested at both low and high frequencies (Figures 22 and 23).
- The 10 ppi hollow screen increases noise levels at frequencies above 2 kHz, even with the UA 0237 inner windscreen fitted. It can be deduced that this is a result of noise being generated by flow through the outer layer (Figures 24 and 25).
- The introduction of turbulence causes noise levels at the control microphone to increase by up to 15 dB at low frequencies (below 125 Hz) and up to 5 dB at high frequencies (Figure 27).
- In turbulent flow, all the test windscreens have the effect of reducing noise at low frequencies. The 30 ppi hollow windscreen appears to be the most effective: this screen reduces low-frequency noise by up to 15 dB, and also reduces high-frequency noise (above 1 kHz) by 2 - 4 dB (Figure 28). The addition of the UA 0237 inner screen to create a two-layer windscreen appears to confer no benefit (Figure 29).
- The 10 ppi solid windscreen is effective at low frequencies, but provides no noise reduction at high frequencies (Figure 32).
- As in smooth flow, in turbulent flow the 10 ppi hollow windscreen is less effective at low frequencies than the 30 ppi screen, and noise levels at high frequencies are increased, compared with the control windscreen, even with the UA 0237 fitted as an inner screen, presumably because of noise generated by flow through the envelope (Figures 30 and 31).

These exploratory tests provided confidence that wind tunnel measurements could provide a basis for rank-ordering windscreens in terms of their effectiveness, in controlled conditions, and for selecting candidate windscreens for outdoor testing. An extended series of wind tunnel tests was therefore undertaken.

7 Further Wind Tunnel Tests

A further series of tests was performed in the wind tunnel in July and August 1995, using a metal grid at the inlet to the working section to create turbulence of an arbitrary intensity and frequency spectrum. The grid size and position relative to the microphones were optimised to produce the greatest increase in wind noise, as measured at the control microphone, compared with the smooth flow measurements, with the objective of allowing the test windscreens to demonstrate their potential.

The tests were directed towards determining the influence of the key variables - configuration, envelope porosity and diameter - on levels of wind noise at the microphone. Not all of the windscreens identified in Table 1 as 'satisfactory' or 'marginal' were tested. After evaluating early results, attention was concentrated on one configuration, the two-layer screen using the UA 0237 or UA 0570/0393 as the inner component, in preference to single-layer and solid screens. This decision was based on two factors:

- For practical reasons, it was considered that a two-layer design was preferable to a single-layer design, although measurements indicated that a single layer could be as effective. The two-layer type uses the control windscreen, mounted directly on the microphone pre-amplifier, as the inner component. This will provide useful additional protection to the microphone against rain, and against mechanical damage if the microphone stand were to be accidentally knocked over, which might cause the wire frame of the outer windscreen to be bent and forced into contact with the microphone.
- All preliminary measurements had shown that hollow screens were more effective than solid screens, which are necessarily built using low porosity (10 or 20ppi) foam to limit the acoustic insertion loss.

7.1 Test Results

Test results are shown in Figures 33 - 42. These figures refer to an air speed of 10 m/s only, for clarity, although tests were carried out at speeds of 5, 7.5, 10 and 12.5 m/s for most windscreens.

Figure 33 shows comparative one-third octave band noise spectra measured in the tunnel at 10m/s, for each test windscreen and the control; the control spectrum is an average of all measurements. It can be assumed that differences between the test and control microphones are the result of differences in levels of wind noise, since both microphones are exposed to the same acoustic field. The positions of test and control microphones in the tunnel were exchanged, to confirm that flow and noise conditions

across the working section were uniform. Although individual data points cannot be easily identified, this plot shows that all the test windscreens provided significant reduction of wind noise at frequencies below 250Hz. From 250Hz - 1 kHz, the test windscreens showed no advantage over the control, although it is possible that any effect in this frequency range is being masked by 'acoustic' noise in the wind tunnel. Most windscreens provided a modest reduction in noise at frequencies above 1 kHz.

The relative performance of different windscreens of different types can be seen more clearly on Figures 34 - 37. The upper plots on each figure show the differences between noise spectra measured at the test microphones and the mean levels measured at the control microphone. A point below the zero line represents a reduction in wind noise by the test windscreen compared to the control. The lower plots show the variations in the levels measured at the control microphone, relative to the mean of these measurements. The control measurements were very repeatable, except for some scatter at 4-5 kHz. The scatter should be taken into account when the significance of small differences in windscreen performance is being assessed.

Figure 38 shows the comparative performance of single and two-layer windscreens, both of 300 mm diameter with 45ppi outer covers.

For the two-layer screens, the basic trends in performance with the main variables (diameter and the porosity of the outer cover) are shown in Figures 39 - 42. These plots are based on measured noise levels in the at 63 Hz and 6.3 kHz one-third octave bands: examination of data indicates that the differences between windscreens in these frequency bands is a measure of their relative effectiveness in reducing wind noise at low and high frequencies.

7.2 Conclusions from Wind Tunnel Measurements

The following conclusions can be drawn from the wind tunnel tests:

7.2.1 Configuration

Taking into account performance and practical aspects, the two-layer windscreen, using the control windscreen as the inner component, is the preferred configuration. This conclusion confirms those of previous studies, described in Appendix A.

7.2.2 Dimensions

For two-layer windscreens at low frequencies, wind noise levels are generally reduced by increasing the windscreen diameter, independent of foam grade, although the slope of the noise reduction/diameter relationship is small (Figure 39).

At high frequencies, wind noise increases with windscreen diameter, independent of foam grade (Figure 40). Again, the slope of the noise-reduction/foam grade relationship is small.

7.2.3 Foam Grade

At low frequencies, 30 and 45 ppi foams produce similar results, 10 and 20 ppi foams are generally inferior (Figure 41).

At high frequencies, 10 and 20 ppi foam windscreens generate higher noise levels than the control windscreen, presumably due to noise generated by flow through the outer screen (Figure 42).

7.2.4 Preferred Configuration

The results of the wind tunnel tests, and consideration of practical aspects, lead to the conclusion that a two-layer windscreen, using a 30 or 45 ppi foam outer cover, was the most effective windscreen configuration. A series of outdoor measurements was then devised, to confirm the validity of results from wind-tunnel measurements, and to identify the optimum diameter and foam grade combination.

8 Outdoor Measurements

8.1 Location

The outdoor tests were carried out at Farley Mount (OS ref SU403291) near Winchester during October 1995. The site is relatively exposed to wind, is some distance from local roads, and vehicle access for the public is restricted, reducing interruptions. Some interference was experienced over a 45 minute period with military helicopters on training flights. Background noise levels were generally low, although there was some noise generated by wind in grass and small trees.

During the tests, the weather was dry, with the wind from the south. Wind speeds were generally between 3 and 8 m/s with occasional lulls, and gusts above 12 m/s.

8.2 Procedure

The measurement set-up was the same as that used for wind tunnel tests, as shown schematically in Figure 18. Sound recordings were made from two windscreens at a time, with simultaneous recording of the output of the anemometer, using two DAT recorders. The internal clocks of the DAT recorders were synchronised before the measurements started, and maintained synchronism throughout the day.

The windscreens under test were placed over B&K Type 4155 microphones on the removable preamplifiers from B&K Type 2230 sound level meters mounted on tripods approximately 2 metres apart, with the anemometer halfway between. Figure 43 shows the site and the arrangement of test windscreens.

Recordings of approximately 40 to 60 minutes' duration were made for each combination of windscreens. The windscreens were exchanged between the two microphones midway through the measurement period to minimise the effect of systematic differences between air flows at the two positions. In the event of interference from extraneous noise sources, the measurement periods were extended to ensure that at least 15 minutes of 'uncontaminated' data was recorded with each windscreen in each position.

8.3 Test Windscreens

Following the wind tunnel tests, outdoor tests were restricted to evaluating the performance of two-layer windscreens. The windscreen comparisons which were carried out are detailed in Table 4.

8.4 Analysis of Recordings

Sound recordings were analysed using a B&K Type 2133 dual channel analyser at 1/3 octave band resolution. A five-second averaging time was selected for the main analysis of the sound recordings, so that a one-third octave band noise spectrum was obtained for each windscreen every five seconds, averaged over the preceding five seconds ($L_{eq,5s}$). The choice of averaging time was based on the findings of the pilot experiment.

The frequency analyser was also used to obtain the wind speeds (via anemometer output voltage) from the tape recordings, and a five-second averaging time was also used so that the wind speed could be obtained for each five-second wind noise sample.

Data for five-second periods containing audible aircraft noise or other disturbances were discarded. Data for 5-second periods were also discarded if the analyzer overloaded during the period.

8.5 Results

Results are presented on Figures 44 - 52.

The upper plots on Figures 44 - 49 show comparative one-third octave noise spectra over the measurement period for each pair of windscreens; the spectra are averaged over the full measurement period (excluding extraneous noise, see 8.4 above). There are two spectra for each windscreen, corresponding to the two measurement periods, the windscreens' positions being exchanged between these measurements. Minimum, maximum and average wind speeds, from the anemometer output averaged over five seconds, are also shown.

The lower plots on Figures 44 - 49 show the differences between the average spectra for each pair of windscreens.

The relative performance of windscreens can also be compared by plotting the levels measured by each microphone in each 5 second averaging period against the other, to generate a scatter diagram. Such plots, for the 63 Hz and 1 kHz octave bands only, for illustration, are shown on Figures 50 - 52. These cover the following comparative tests:

- 200 mm/45 ppi windscreen - v - UA 0237
- 300 mm/45 ppi windscreen - v - UA 0237
- 300 mm/45 ppi windscreen - v - 200 mm/45 ppi windscreen

8.6 Effect of Windscreens on L_{10} and L_{90} Values

Further analysis was carried out by replaying selected tape recordings to a sound level meter (B&K Type 2236) in order to obtain L_{10} and L_{90} noise levels, ie the levels exceeded for 10% and 90% of the measurement time with time-weighting 'F' (formerly 'fast' response) and frequency-weighting 'A'. The recordings analysed were of the

200 mm/45 ppi windscreen - v - UA 0237

300 mm/45 ppi windscreen - v - UA 0237

The measurement period was 10 minutes from the start of each recording. The measured levels are given in Table 5. The L_{eq} values for the same recordings as previously measured with the frequency analyser are also given. Note that these values are given as an illustration only, and will be dependent upon the wind conditions and local topography at the site, as well as on ambient noise levels.

8.7 Observations

The outdoor measurement results were consistent with the wind tunnel results reported in Section 7, in terms of the rank-ordering of windscreen types. The main difference was that the reduction in wind noise, relative to the control, extends over a wider frequency range, up to about 500 Hz. This is evident from comparison of Figures 35 and 44 (for example). This may be a result of the 'masking' of wind noise reduction by background noise in the tunnel tests, or by different inflow turbulence characteristics, or a combination of these factors.

The potential benefits of an improved windscreen are illustrated in Figures 53 and 54. Figure 53 shows typical 5-second averaged spectra for control and test windscreen systems in the absence of extraneous noise, showing the expected differences arising from the wind noise reduction afforded by the 300 mm/45 ppi test windscreen. Figure 54 shows comparative spectra averaged over a five second period during the passage of an aircraft, which was clearly audible. The aircraft noise spectrum has a characteristic peak in the 160 kHz band, which is clearly identifiable on the test windscreen recording, but completely masked by wind noise on the control windscreen recording. It is evident that the greater effectiveness of the test windscreen enabled noise levels associated with this event to be measured, whereas the control measurement system record no useful data. The mean wind speed during the event was approximately 6 m/s.

9 Overall Conclusions from Wind Tunnel and Outdoor Measurements

The following observations and conclusions arise from the test data presented in Sections 6, 7 and 8.

The high-porosity (10 ppi and 20 ppi) windscreens generate higher noise levels at high frequencies than the control windscreen. This is presumed to be caused by noise generated by flow through the outer envelope. The 10/20 ppi screen materials can be excluded from consideration for this reason alone.

The lowest porosity (80 ppi) foam windscreen was included in the outdoor test series for completeness, although the 80 ppi material had already been excluded on the grounds of its excessive acoustic insertion loss (Section 4). It is evident that the 80 ppi foam provides no performance advantage over the 30 or 45 ppi foam at low frequencies. The 80 ppi windscreen did appear to reduce wind noise more effectively at high frequencies, even when the enhanced insertion loss is taken into account. However, the 60/80 ppi materials offer no significant performance advantage over the 30/45 ppi materials to offset the problems which would be involved in correcting for the high-frequency insertion loss of these materials.

The 30 and 45 ppi windscreens are equally effective in reducing wind noise, within the limits of experimental uncertainty. The 30 and 45 ppi materials are the most suitable, of those tested, as windscreen covers. The 45ppi material offers slightly better acoustic insertion loss characteristics.

The influence of windscreen diameter is quite small. The 400 diameter windscreen offers marginally better performance than the 300 and 200 diameter screens. With 30 or 45 ppi covers, the 300 mm windscreen generates slightly higher wind noise levels than the control windscreen at frequencies around 1 kHz, and is inferior to the 200 windscreen except at very low frequencies (below 160 Hz).

The 400 mm windscreen is quite cumbersome to transport, and presents considerable support problems in windy conditions.

Overall, the preferred windscreen configuration of those tested is a two-layer windscreen, with an outer cover of 45 ppi foam, a diameter of 200 - 300 mm, and the standard UA 0237 or UA 0570/0393 as the inner screen. During the outdoor tests, these screens reduced wind noise, compared with the control windscreen, by approximately 15 dB in some one-third octave bands below 250 Hz, and by 6 dB(A), in a mean wind speed of approximately 6 m/s. The 300 mm windscreen provides greater wind noise reduction at low frequencies than the 200 mm windscreen, but is inferior at high frequencies.

10 Effect of Water Absorption

During rain, windscreens will become wet; water will be retained in the porous outer layer, and, in extreme cases, may penetrate to be absorbed by the inner screen. The presence of water in the pores of the foam material will modify the characteristics of the material, and might be expected to affect the performance of the windscreen.

Simple tests were carried out to evaluate the effects of water absorption on the insertion loss of the control and the preferred 200 and 300 mm diameter two-layer windscreens. The measurements were made in the anechoic chamber, using the technique described in Section 4. Tests were carried out with dry windscreens; windscreens were then sprayed with water until it was judged that the exposed surfaces were saturated, with water dripping freely from the screens.

The acoustic insertion losses due to water spraying, compared with the dry screens, are shown on Figure 55. From these data, it can be concluded that the effect of water absorption on insertion loss is not significant; generally, the effect of water was less than 1 dB, except in the 6.3 kHz band for the 300 mm windscreen, when the insertion loss was 1.4 dB.

The degree of 'wetness' of the test screens may not be representative of the wetness of a screen exposed to rain outdoors. However, the test screens were sprayed over their entire surface including the underside; in outdoor conditions, particularly in wind, it might be expected that the underside and downwind side of a windscreen might remain relatively dry. The test measurements therefore can be considered to represent a worst case. For practical purposes, the effect of water on the acoustic insertion loss of the windscreens can be ignored.

Manufacturers data for the effect of water on the B&K 0237 windscreen is shown in Appendix B. Results are not identical with those of the tests reported above for this screen, but confirm the overall conclusion that water absorption has little effect on the acoustic characteristics of this type of foam.

It is possible that water absorption may also affect the air flow around and through the windscreen, and hence affect the levels of wind noise generated at the microphone, compared with a dry screen. This effect has not been investigated. It might be deduced that since water has a negligible effect on the insertion loss of the windscreens, the flow resistance characteristics of the foam are not greatly modified and the windscreen performance should be little-affected.

It is not clear whether this aspect requires further investigation. For many reasons, measurement of noise levels during rain is undesirable. Propagation conditions are changed, and additional noise is generated by rainfall on local objects and on the

windscreen itself. Some noise sources (for example, traffic noise) are enhanced in wet weather. Measurements during rain would therefore not normally be considered valid for the purpose of environmental noise assessment. There is a difficulty with unattended measurement systems, in that some logged measurements may be made during rain, or after rain when the windscreen is still wet.

11 General Discussion - Measurements in Windy Conditions

11.1 Characterisation of Windscreen Performance

One objective of this study was to characterise the performance of the 'preferred' windscreen design. It would obviously be useful to be able to establish a relationship, between wind noise and some readily-measured wind parameters. A user would then be able to determine whether and to what extent an outdoor measurement had been 'contaminated' by wind noise.

Brüel and Kjær provide such data for the standard windscreens. This data is based on laboratory tests in steady airflows. Real winds are subject to velocity fluctuations. Figure 56 shows a typical time history of 5 second averaged wind speed at the Farley Mount site over a 20 minute period.

The sound power of noise generated by the flow of air over a microphone or other obstruction will generally be proportional to the air velocity to the fifth power. A doubling of wind speed will result in a 15 dB increase in the level of wind noise. This means that in a fluctuating wind, the time-averaged noise level will be largely determined by the wind speed during the gusts, rather than by the average wind speed during the measurement interval. Wind noise level and spectral characteristics will also be influenced by the scale and intensity of the turbulence in the airflow. These factors will themselves be a function of instantaneous wind velocity.

For these reasons, it might be concluded that there can be no unique relationship between wind noise and average wind speed (however measured) in a randomly fluctuating wind. This supposition is supported by Figures 57 and 58. These figures show noise levels in two separate one-third octave bands (63 and 1 kHz) measured with the UA 0237, 200/45 ppi and 300/45 ppi windscreens, plotted against 5 second average wind speed. For a given average wind speed, average ($L_{eq,5s}$) noise levels show a scatter of the order of 10 dB in the 63 Hz band, and 5 dB in the 1 kHz band. The scatter can be presumed to be a result of the different temporal or spectral characteristics of the unsteady air flow between 5 second periods during which the average wind speed was the same.

Scatter diagrams of the form of Figures 57 and 58 could be constructed for all frequency bands, and for the 'A'-weighted overall sound level. 'Best fit' lines could be calculated to provide a mean relationship between wind noise and wind speed. However, such a relationship would conceal the experimental scatter, and could be misleading. It might also be the case that the data is site- or wind-specific. Measurements on a different site with different local topography and more or less local obstructions, or in different meteorological conditions, might yield a significantly different relationship.

For these reasons, no detailed attempt has been made to characterise the performance of the preferred windscreens. Further investigation of the relationship between wind parameters and the level and spectrum of wind noise would present a challenging area for further research, but it is unlikely that the outcome of such research would be of benefit to those involved in practical noise measurements outdoors.

11.2 Practical Considerations

The outcome of the study is a design and specification for an improved windscreen, which significantly reduces wind noise compared with the standard windscreen. The performance cannot be reliably quantified. In practical terms, the user must accept that a noise level measured represents an upper bound to the actual noise level resulting from the source in question.

It is often possible to reach a subjective judgement on whether wind noise is influencing a noise measurement by monitoring the sound level meter output through headphones.

Attempts have been made to discriminate between 'source' noise and wind noise in fluctuating winds by measuring the statistical noise level L_{90} , rather than the time-averaged (L_{eq}) noise level. Background noise is, by definition, measured as an L_{90} . However, the use of L_{90} as a 'proxy' for L_{eq} for source noise measurement is of uncertain validity, especially where large propagation distances are involved and the source noise likely to fluctuate in level. The validity of L_{90} measurements in these circumstances deserves some investigation.

12 Proposals for Further Development

The preferred windscreens (200 or 300 mm diameter) are practical designs. However, some refinements would be desirable:

- It is possible that a windscreen of intermediate diameter (eg 250 mm) would offer an effective compromise between the 200 and 300 mm windscreens, in terms of optimising low- and high-frequency performance.
- The existing designs are adequate and robust, but deployment outdoors in wind, especially at night, might present some difficulties. Some mechanical improvements could be made to simplify the fitment of the windscreen to the microphone. The method of fitting the top and bottom foam 'discs' could also be improved.

The general use of the improved windscreen on a range of sites in a range of wind conditions would provide the opportunity to obtain valuable feedback on performance. This could be achieved by making a test windscreen available, at nominal cost, to companies or individuals involved in outdoor noise measurements, particularly at wind energy sites. Ideally, these users would make simultaneous two-channel recordings of noise from systems using the standard and improved windscreens, and carry out simple measurements of average wind speed. These data could then be analysed to determine whether the windscreen performance can be quantified in a useful way, and to determine the performance gain over the standard windscreen in a range of conditions.

Table I

Matrix of test windscreens and assessment of free field response corrections

Windscreen Description	Grade of foam ppi					
	10	20	30	45	60	80
Hollow windscreens - single layer (20 mm thick outer envelope only)						
200 mm diameter	✓	✓	x	✓	x	x
300 mm diameter	✓	✓	?	✓	x	x
400 mm diameter	✓	✓	✓	✓	x	x
Two-layer windscreens - 20 mm thick outer envelope with UA 0237 inner screen						
200 mm diameter	✓	✓	?	?	x	x
300 mm diameter	✓	✓	?	?	x	x
400 mm diameter	✓	✓	?	?	x	x
Two-layer windscreens - 20 mm thick outer envelope with UA 0570/0393 inner screen						
200 mm diameter	?	x	x	?	x	x
300 mm diameter	✓	?	?	?	x	x
400 mm diameter	✓	?	x	x	x	x
Solid windscreen						
200 mm diameter	✓	x	x	x	x	x
300 mm diameter	?	x	x	x	x	x
Control windscreens						
UA 0237	✓					
UA 0570 + UA 0393	✓					
(✓)	=	Satisfactory - free-field insertion loss < ±1 dB (25 Hz - 10 kHz)				
(?)	=	Marginal - free-field insertion loss < ±3 dB 25 Hz - 10 kHz, < ±1 dB 50 Hz - 5 kHz				
(x)	=	Unsatisfactory - insertion loss outside the above range.				

Table 2

Windscreens tested during exploratory measurements in the wind tunnel

Configuration/ Diameter mm	Foam grade ppi		
	10	20	30
Single-layer 300	x	-	x
Two-layer (OA0237 inner) 300	x	-	x
Solid 300	x	-	-
	'x' = windscreens tested		
Control windscreen - UA 0570/0393 (The UA 0237 foam ball screen was also tested against the control).			

Table 3**Test Windscreens**

The following windscreens were tested:

Configuration/ Diameter mm	Foam grade ppi			
	10	20	30	45
Single-layer 200 dia	-	-	-	-
300 dia	-	-	-	x
400 dia	-	-	-	-
Two-layer (UA 0237 inner) 200 dia	x	x	x	x
300 dia	x	x	x	x
400 dia	x	x	x	x
Solid 200 dia	x	-	-	-
300 dia	x	-	-	-
Control windscreen - UA 0570/0393				
Windscreens tested against control: 'x'				
Windscreens not tested: -				

Table 4

Comparison of windscreens outdoors

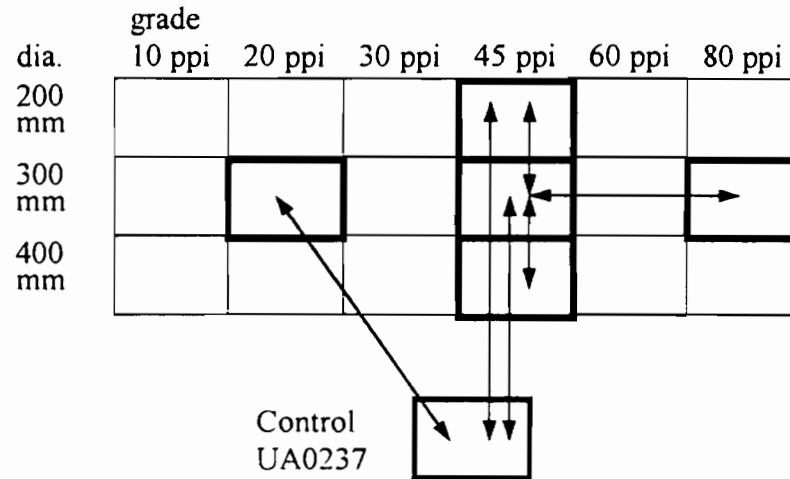

Windscreens tested in pairs as indicated by the arrows.

Table 5

L_{10} and L_{90} levels measured simultaneously at test and control windscreens

Test windscreen	Noise descriptor	Level at Test windscreen, dB(A)	Level at UA 0237 Control windscreen, dB(A)	Level difference, (Control-Test)
200 mm/45 ppi (first period)	L_{10}	52.0	58.0	6.0
	L_{90}	43.0	47.0	4.0
	L_{eq}	48.5	54.0	5.5
200 mm/45 ppi (second period)	L_{10}	51.0	57.0	6.0
	L_{90}	44.0	47.0	3.0
	L_{eq}	49.0	54.5	6.0
300 mm/45 ppi (first period)	L_{10}	53.0	60.0	7.0
	L_{90}	45.0	48.0	3.0
	L_{eq}	52.0	59.0	6.5
300 mm/45 ppi (second period)	L_{10}	55.0	61.0	6.0
	L_{90}	45.0	50.0	5.0
	L_{eq}	51.0	57.0	6.0

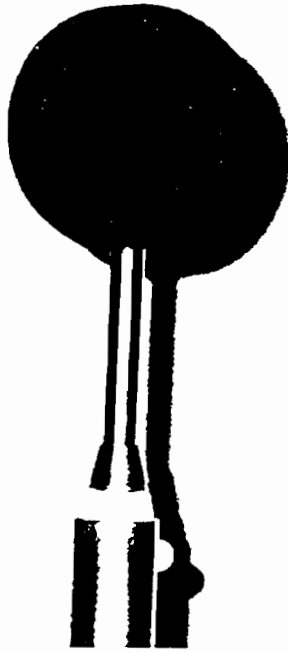

Figure 1 **B&K UA 0237 Windscreen**



Figure 2 **B&K UA 0570 Windscreen**

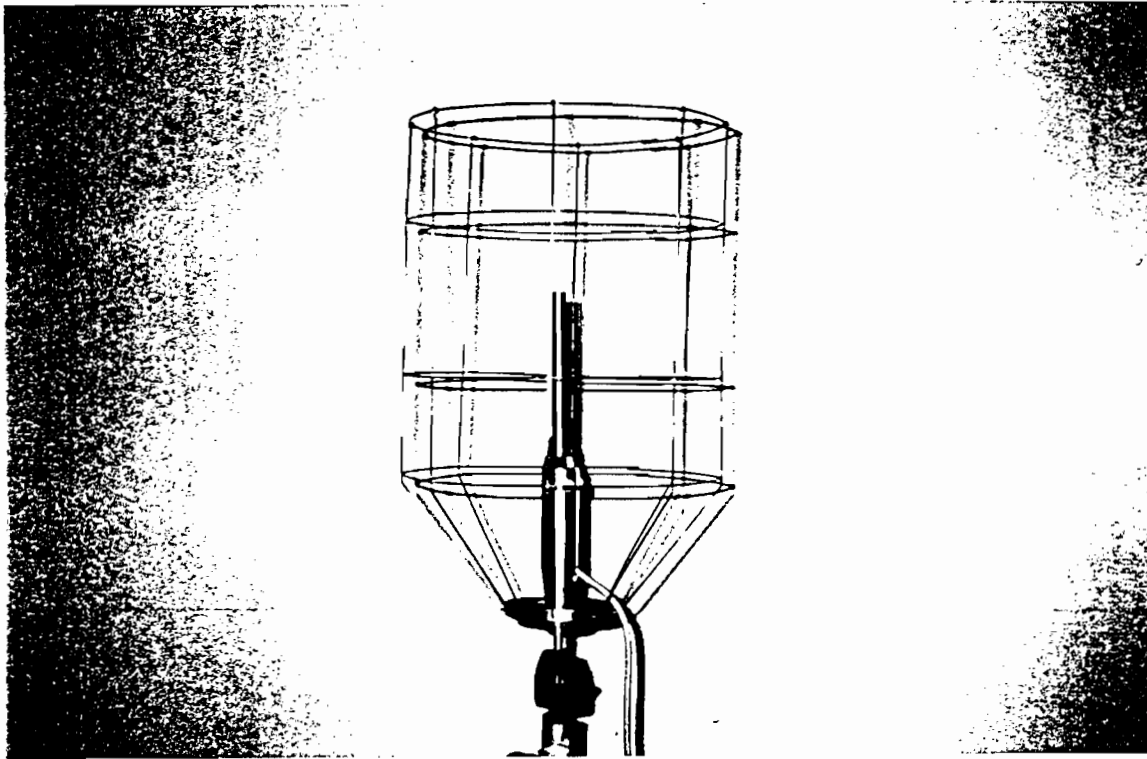

Figure 3 Frame construction for test windscreens, showing microphone and pre-amplifier mounted

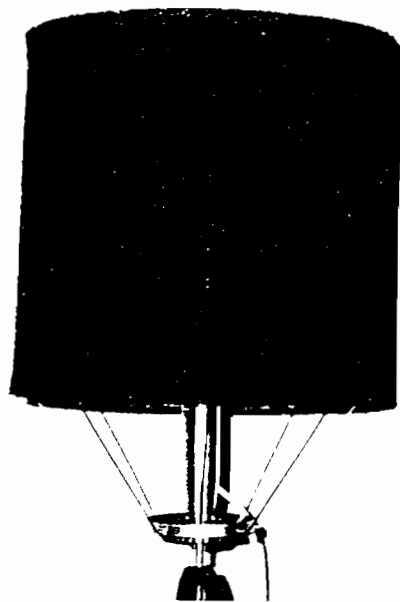

Figure 4 Installation of outer sleeve (10 ppi) on windscreen

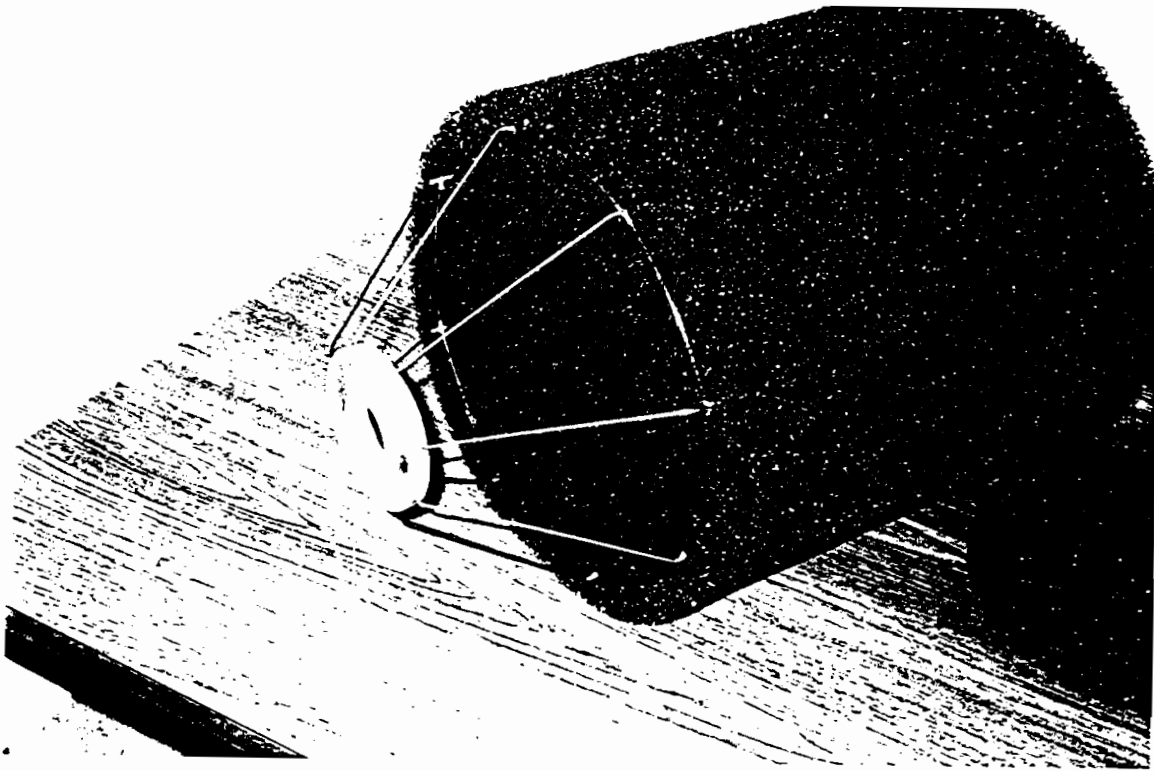

Figure 5 **Mounting plate at base of windscreen**

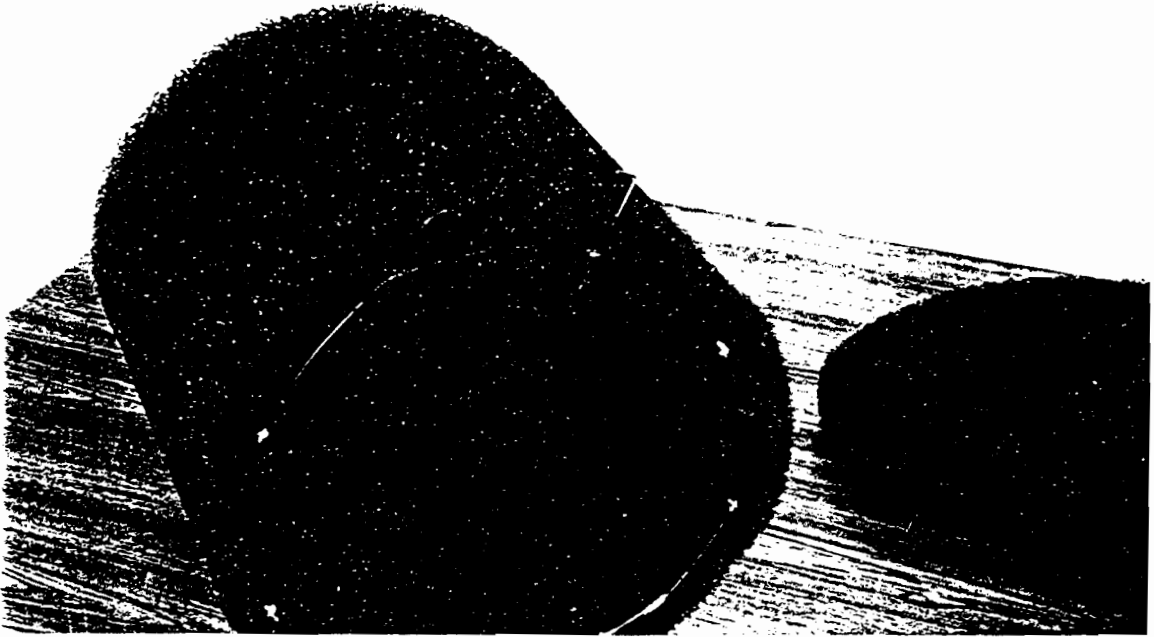

Figure 6 **Installation of top-bottom**

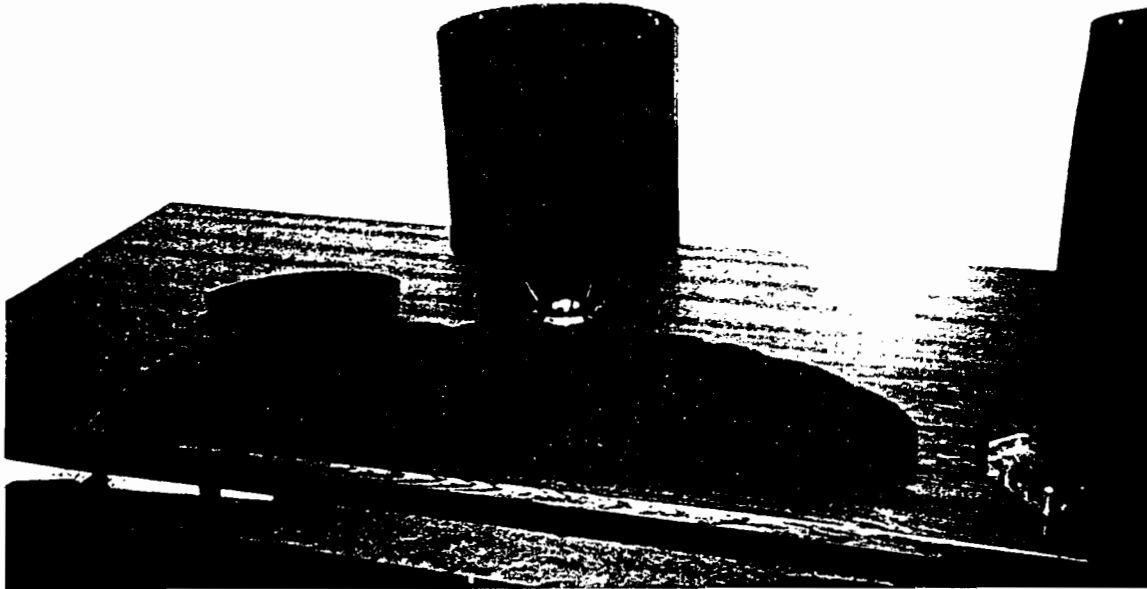

Figure 7 Construction of solid windscreen using stacked discs in outer sleeves



Figure 8 400/300/200 mm test windscreens with UA 0237/UA 0570 for comparison

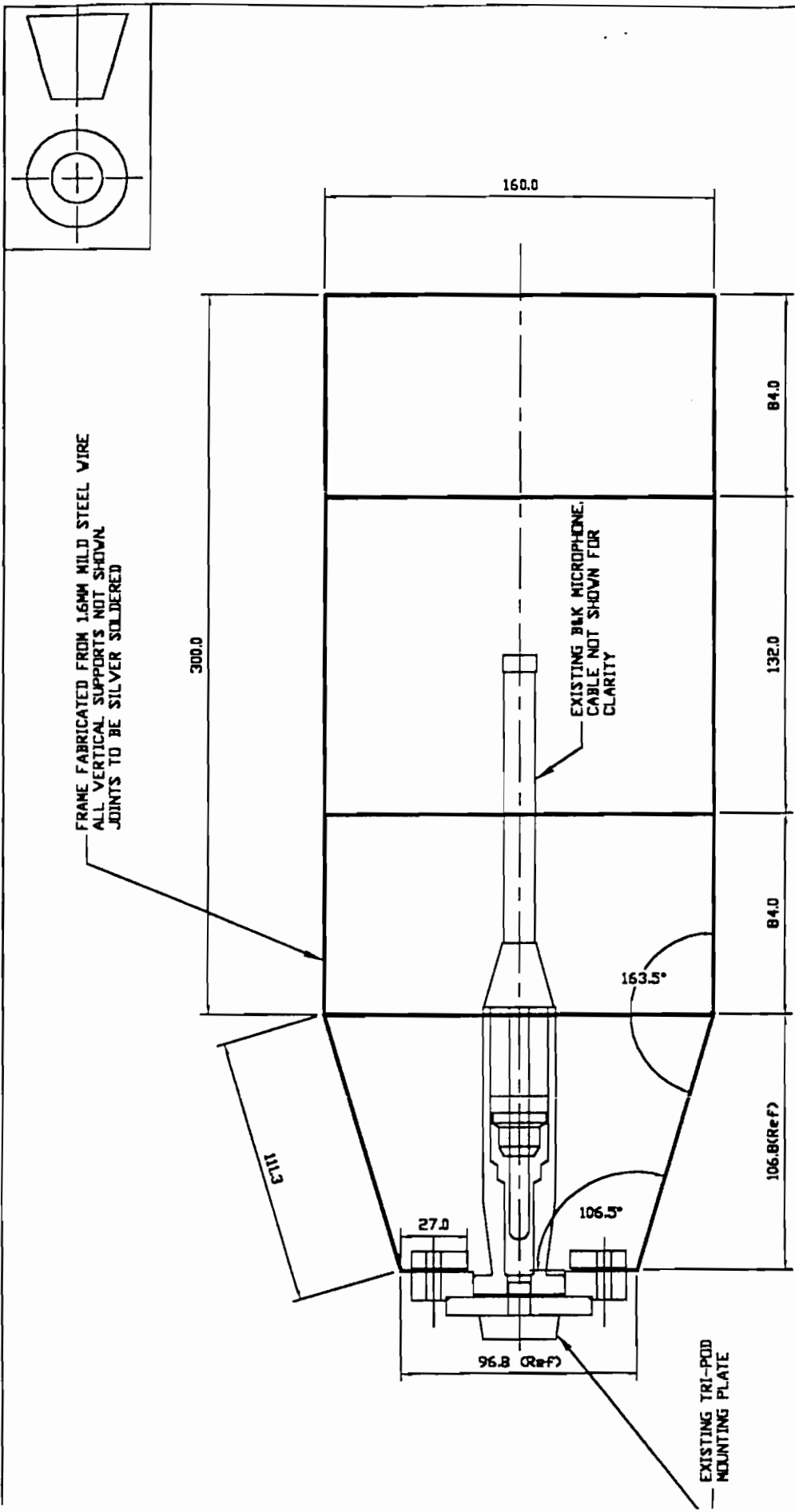

Figure 9 Sketch of windscreen frame and mounting plate
- 200 mm diameter test windscreen

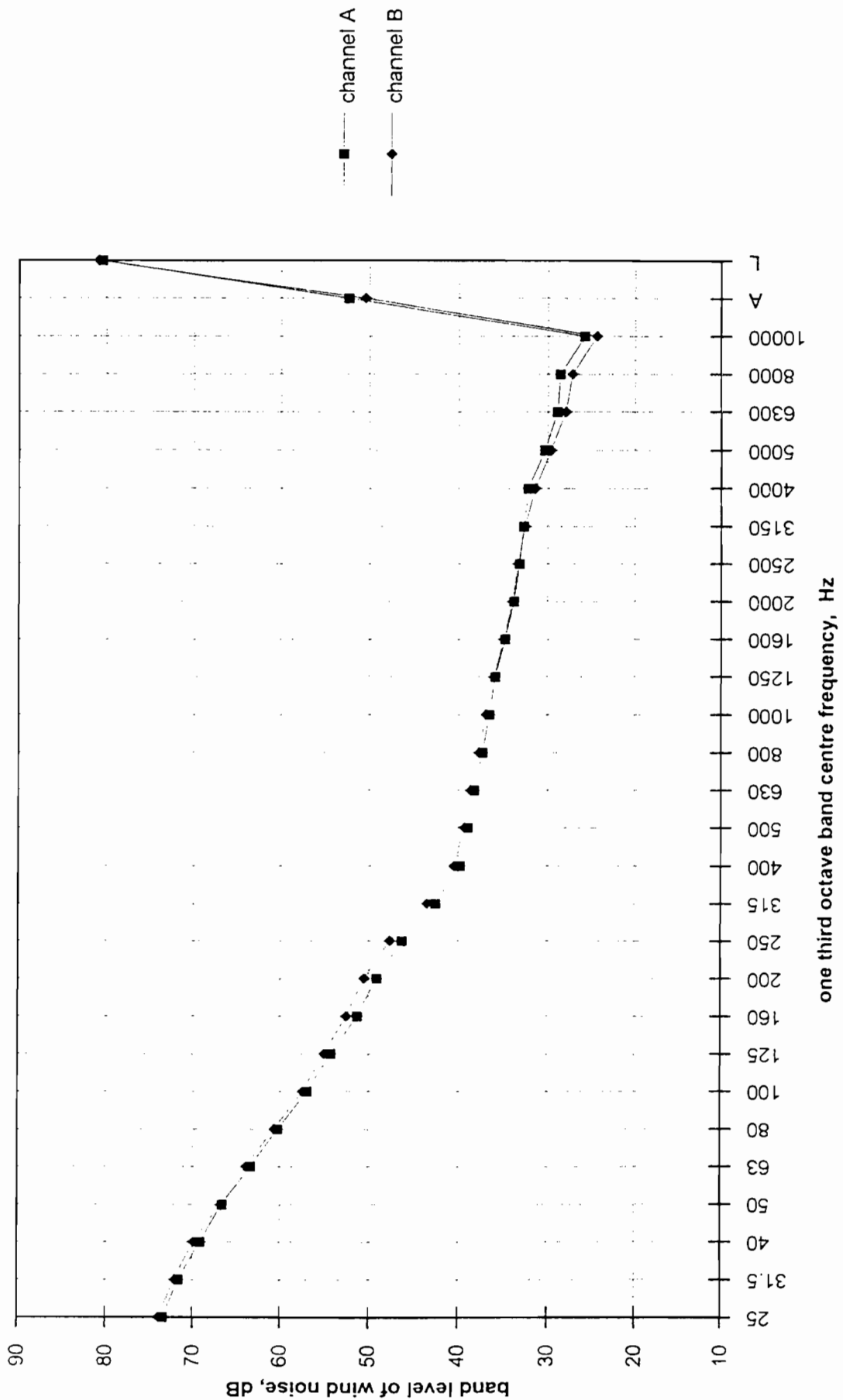

Figure 10 Noise spectra from adjacent microphones with UA 0237 windscreens - averaged over 500 seconds

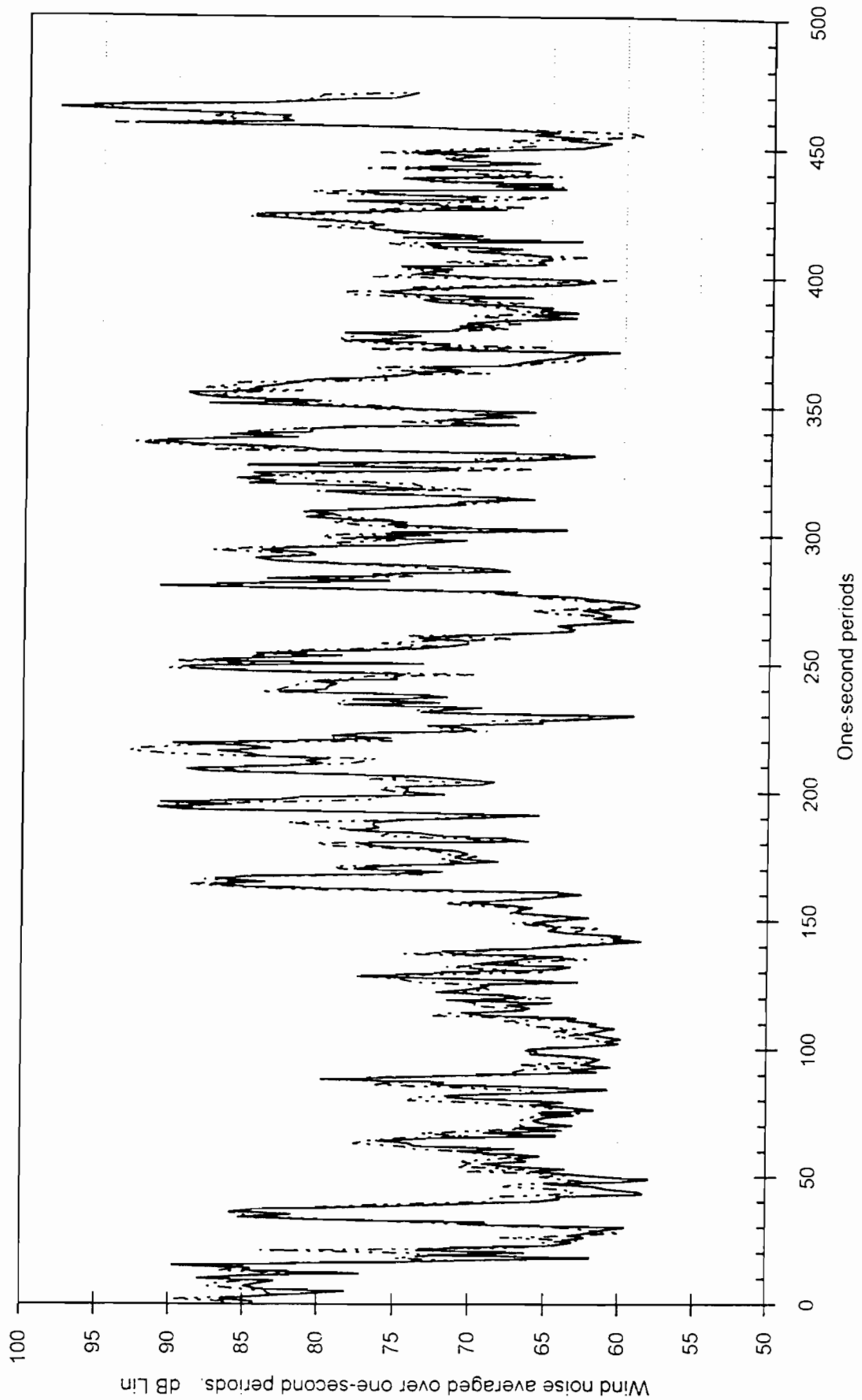

Figure 11 Time histories of unweighted SPL's from adjacent microphones - 1 second averaging

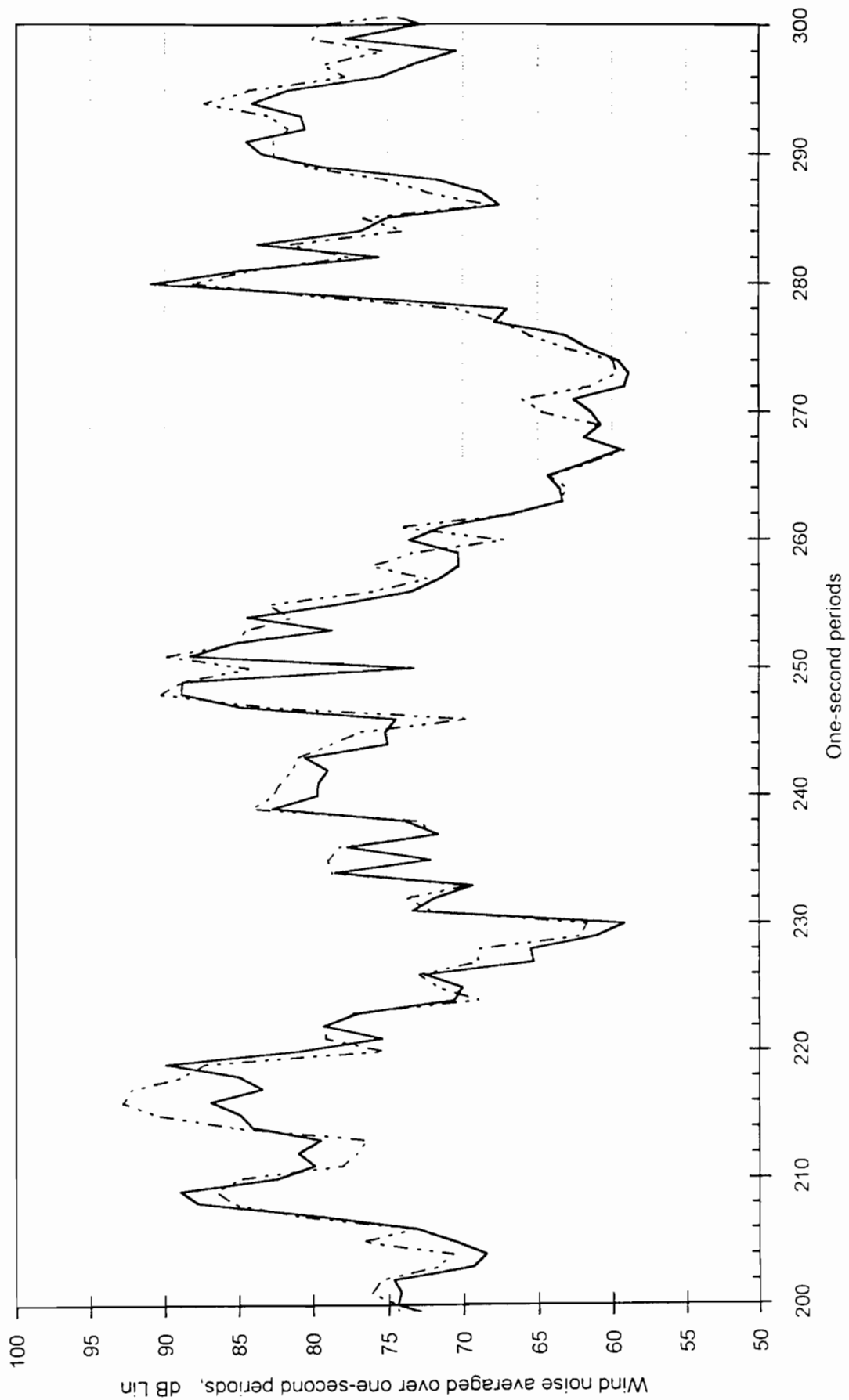

Figure 12 Expanded time histories of unweighted SPL's from adjacent microphones - 1 second averaging

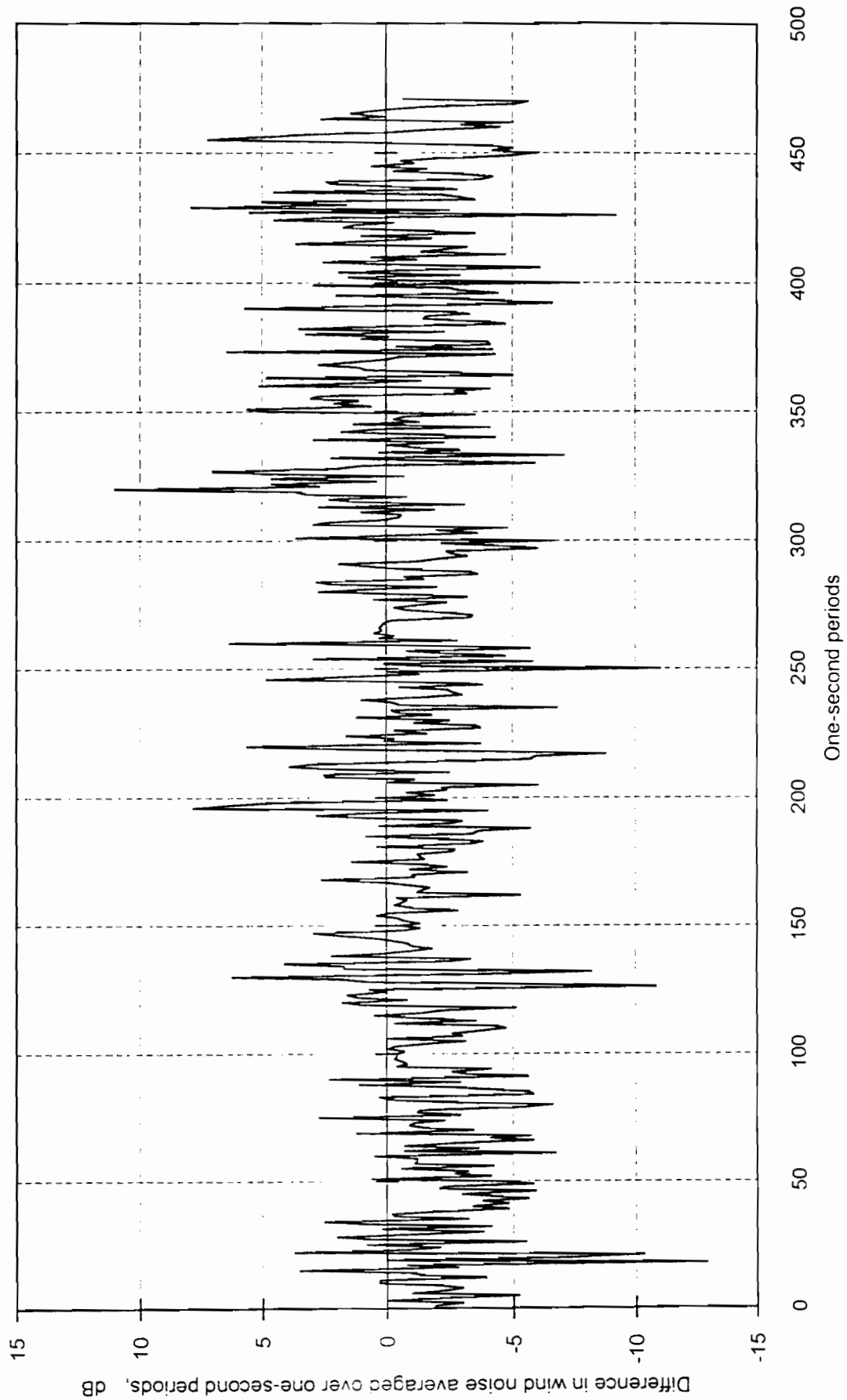

Figure 13 Differences between unweighted SPL's from adjacent microphones - 1 second averaging

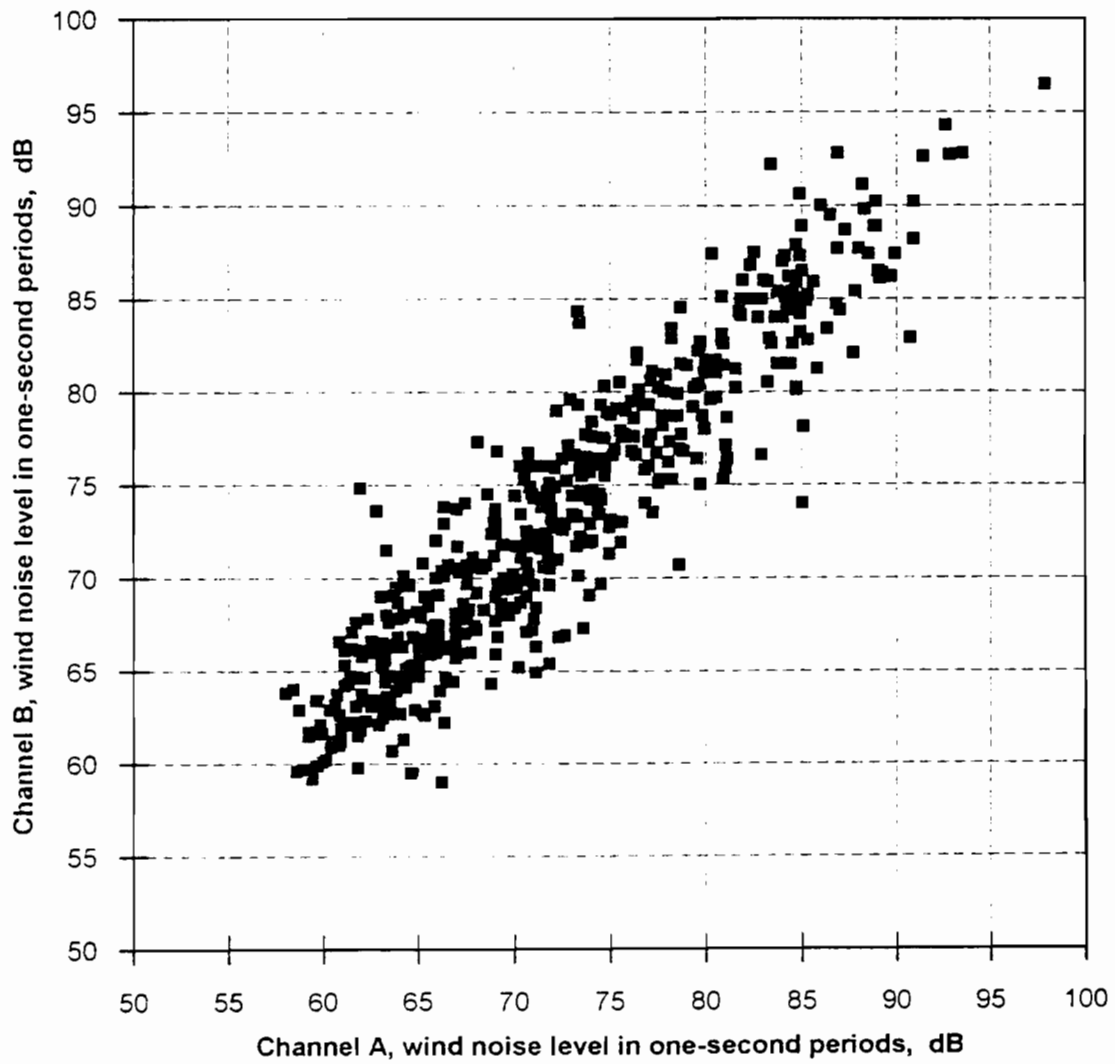
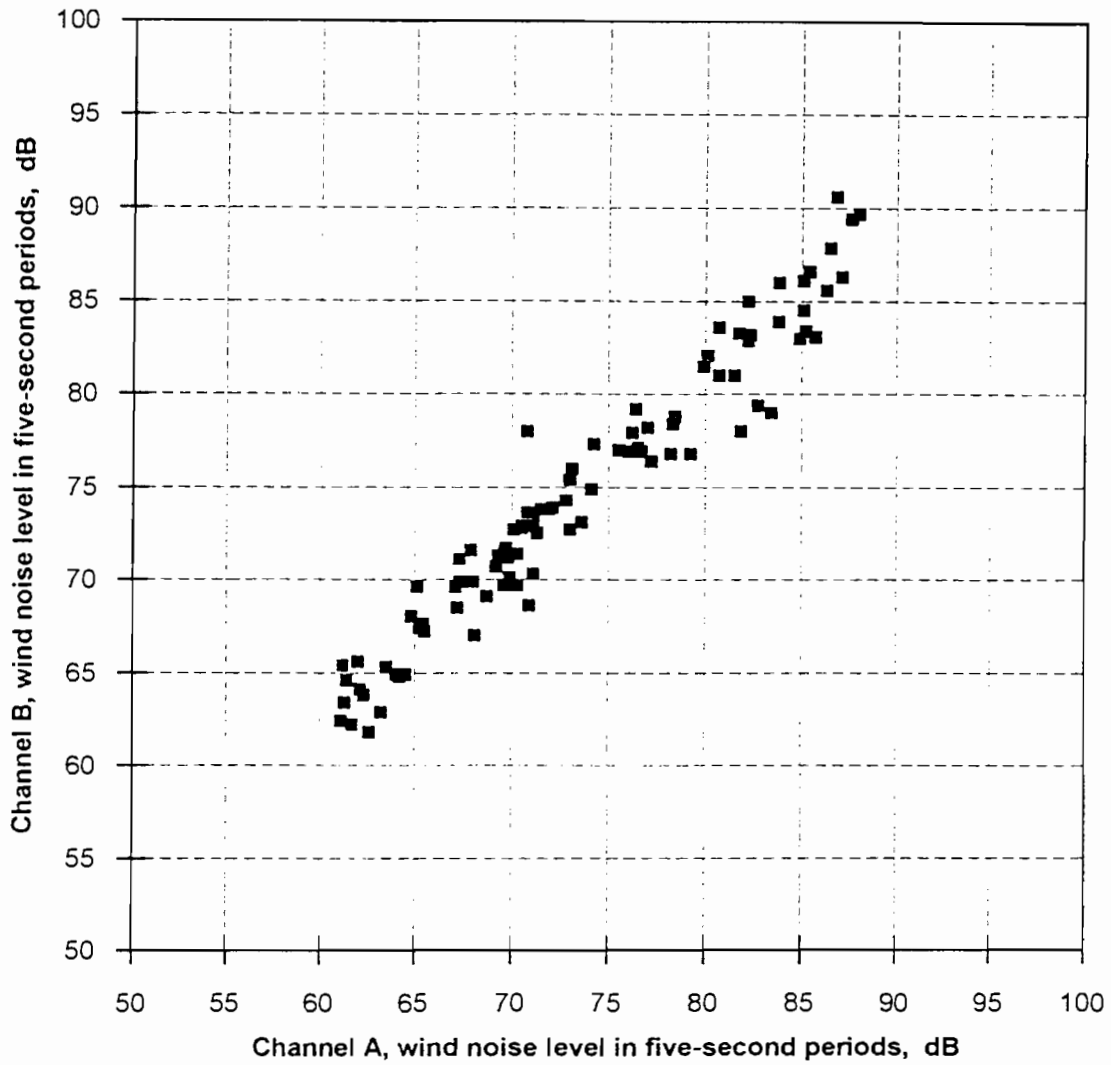

Figure 14 Overall SPL's from adjacent microphones with UA 0237 windscreens
- 1 second averaging



**Figure 15 Overall SPL's from adjacent microphones with UA 0237 windscreens
- 5 second averaging**

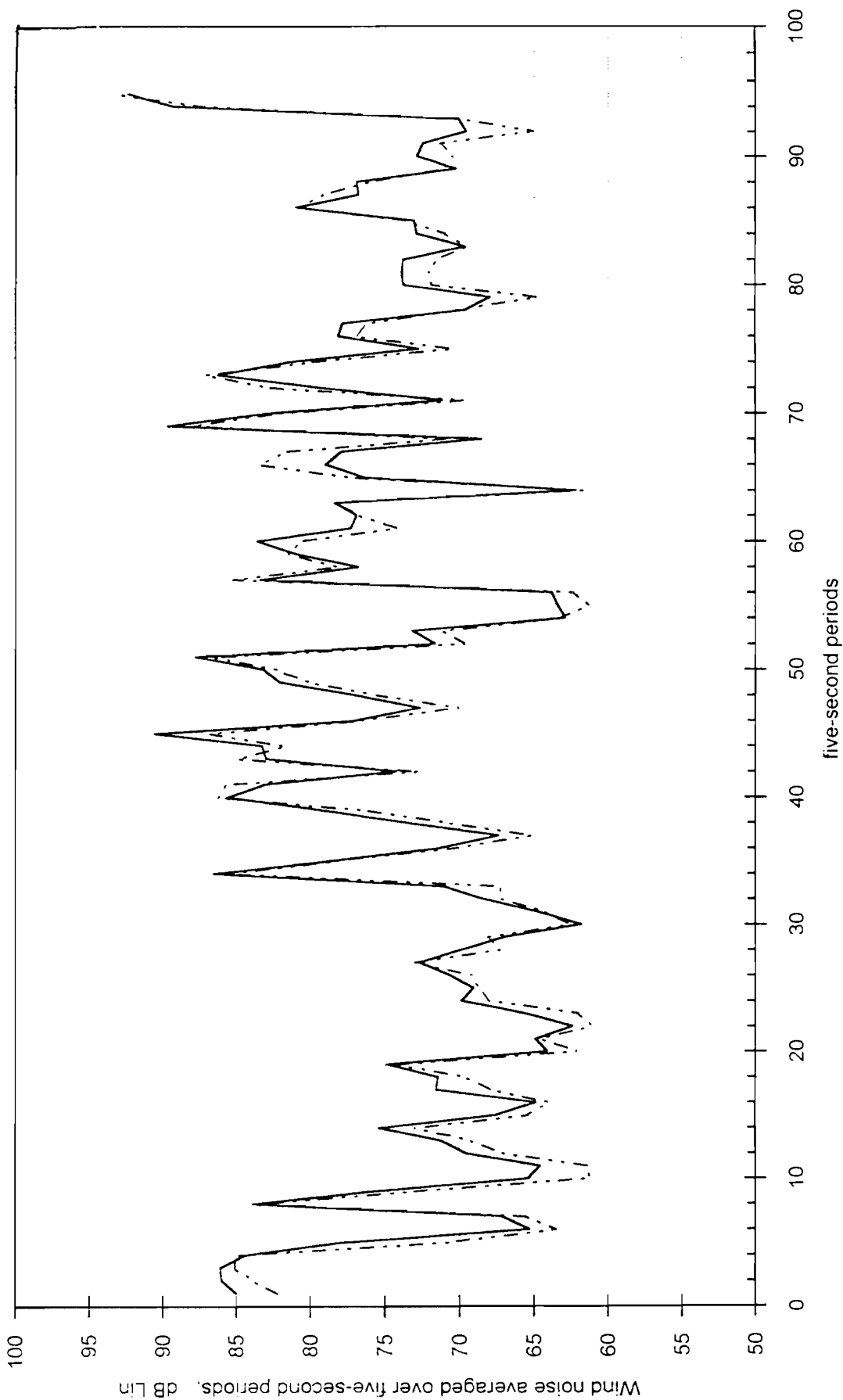

Figure 16 Time history of unweighted SPL's from adjacent microphones with UA 0237 windscreens - 5 second averaging

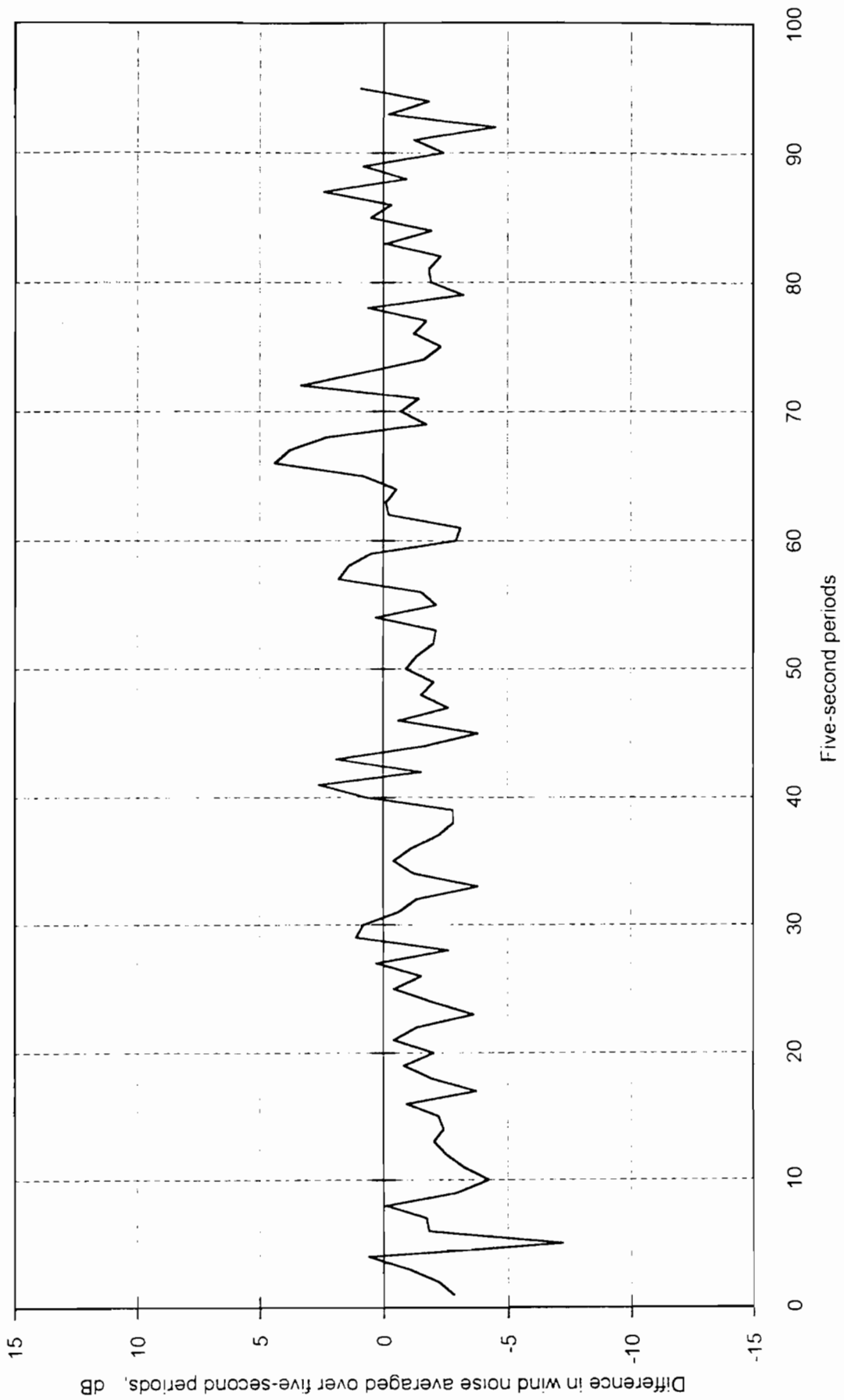

Figure 17 Differences between unweighted SPL's from adjacent microphones with UA 0237 windscreens - 5 second averaging (see Figure 16)

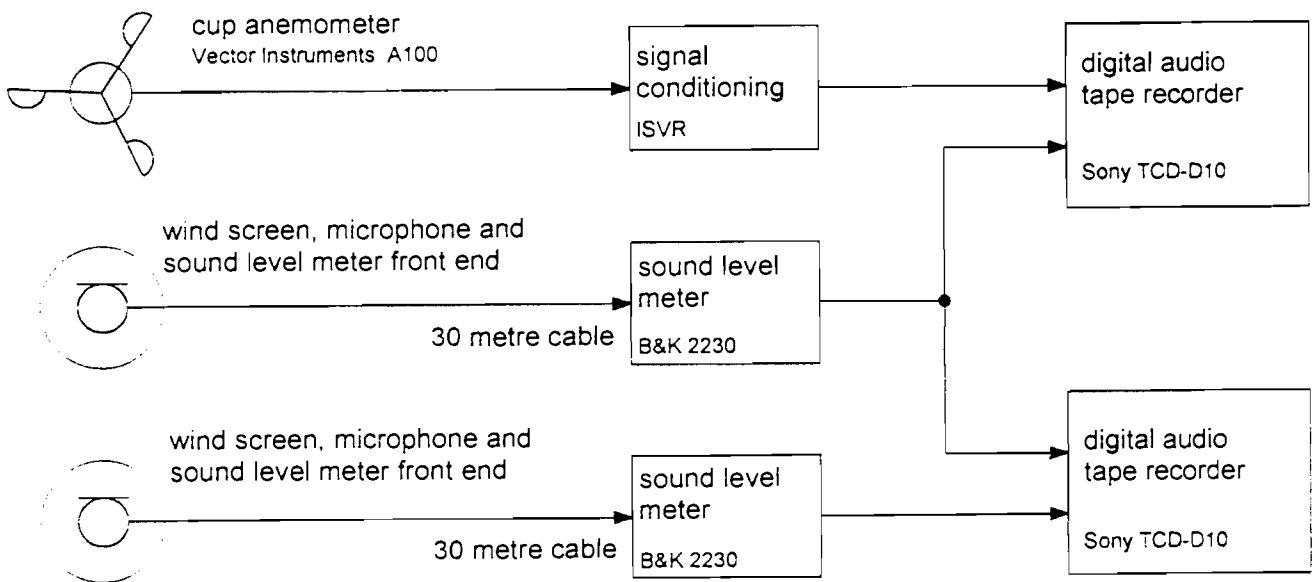

Figure 18 Measurement system for wind tunnel and outdoor measurements - schematic

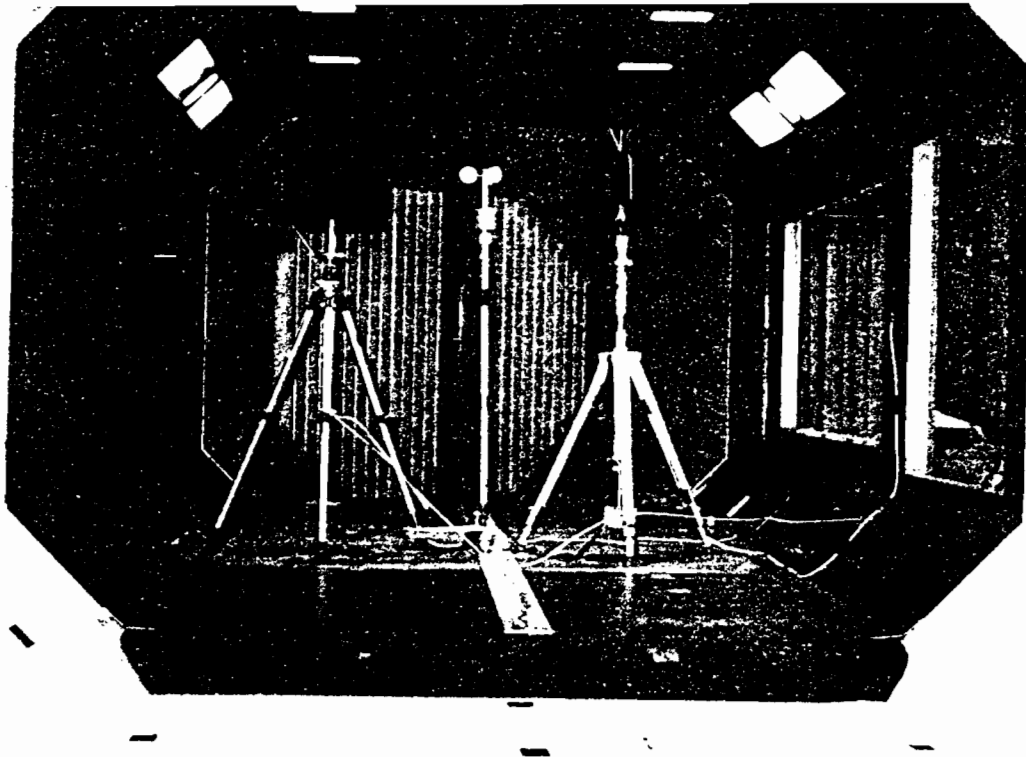

Figure 19 Installation of windscreens and anemometer in 7' x 5' wind tunnel

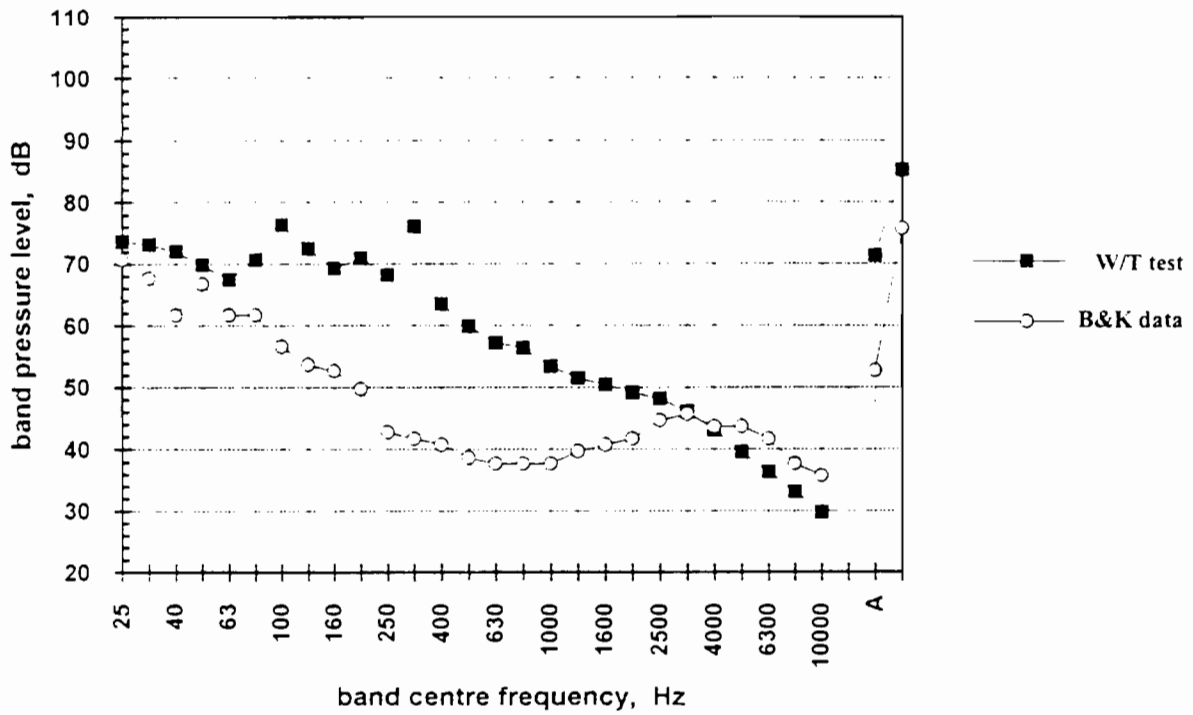

Figure 20 UA 0237 in wind tunnel -v- B&K data for wind noise (10 m/s)

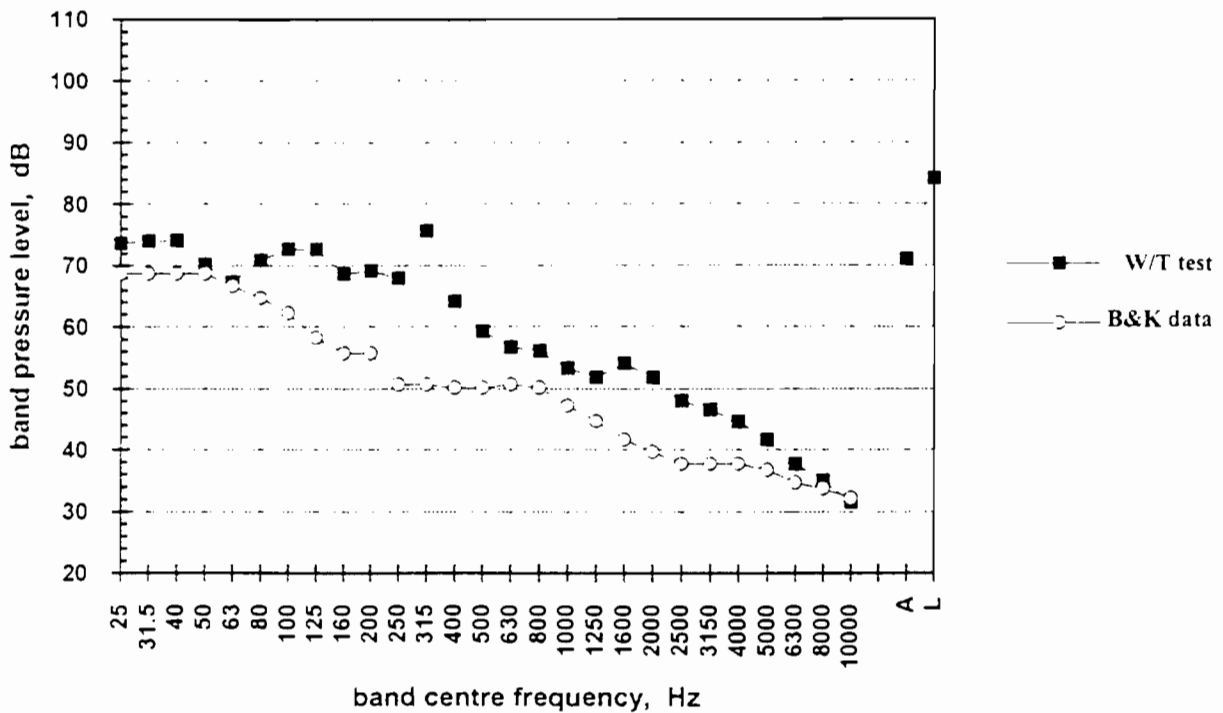

Figure 21 UA 0570 in wind tunnel (without 0393) -v- B&K data for wind noise

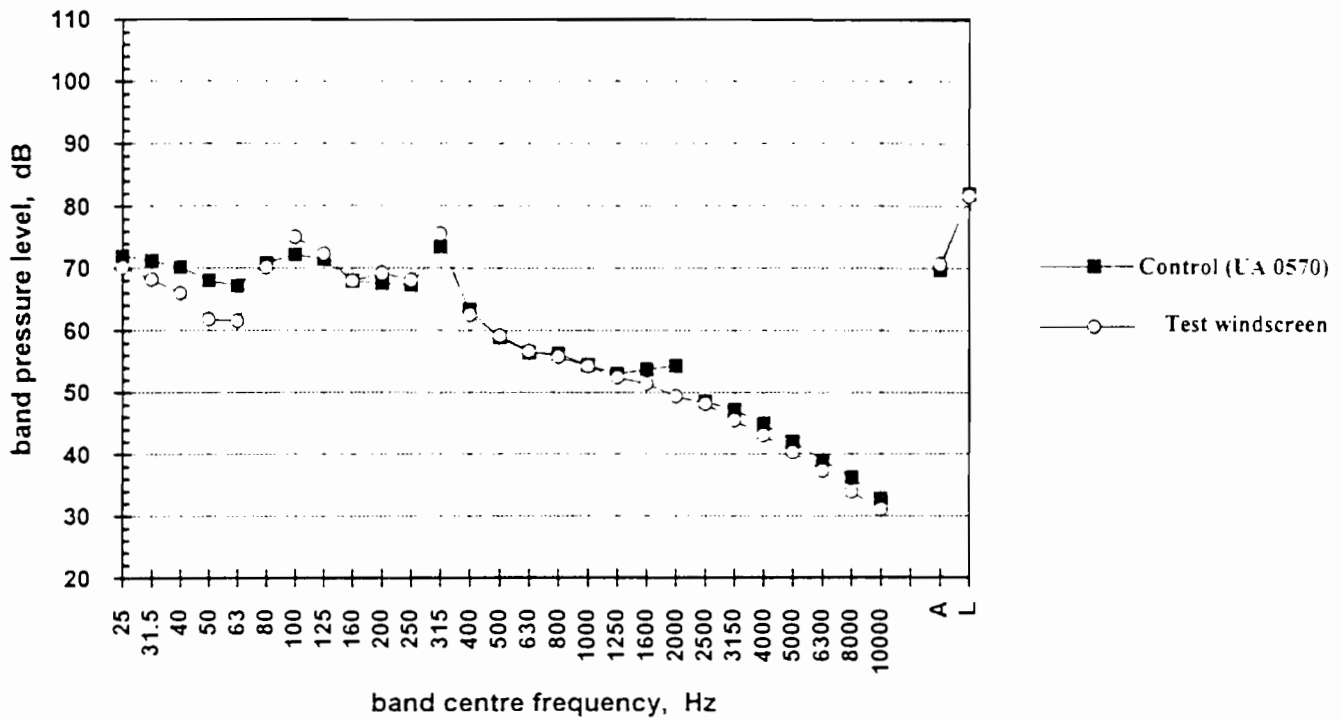

Figure 22 30 ppi hollow windscreen -v- UA 0570 - smooth flow 10 m/s

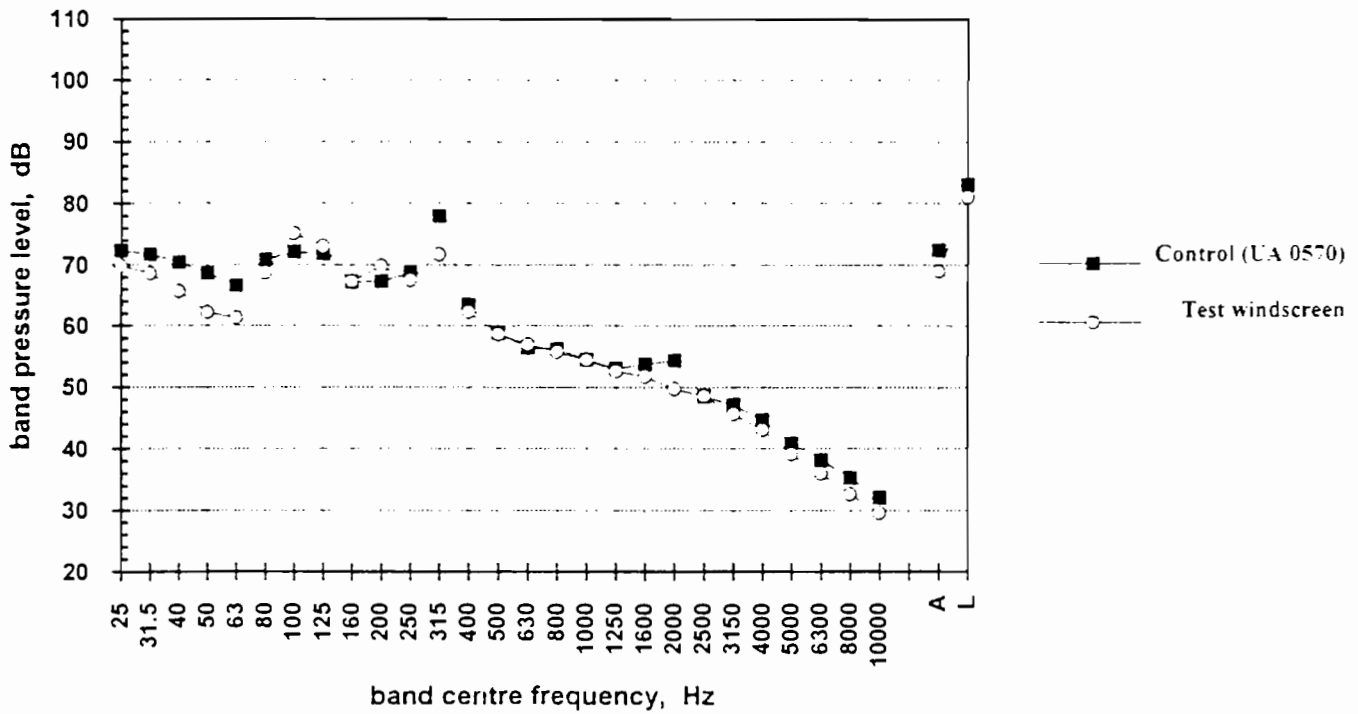

Figure 23 30 ppi hollow windscreen + UA 0237 -v- UA 0570 - smooth flow 10 m/s

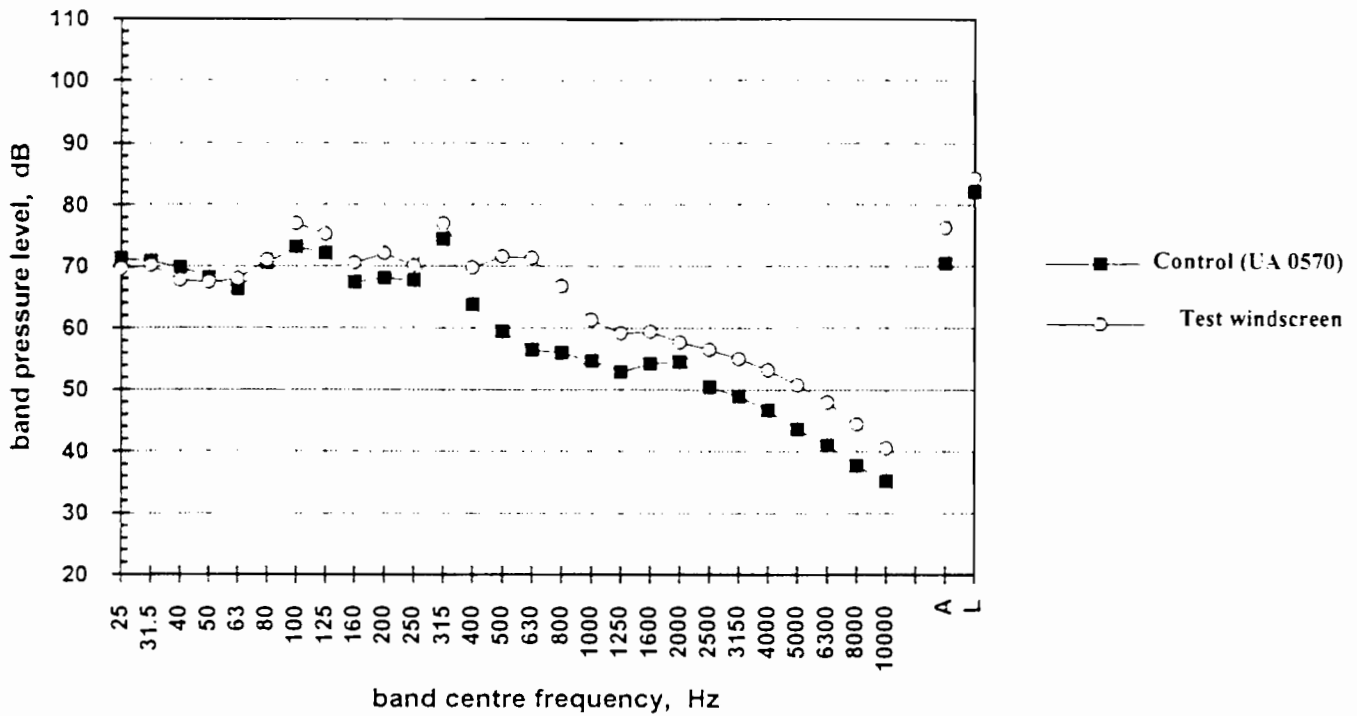

Figure 24 10 ppi hollow windscreen -v- UA 0570 - smooth flow 10 m/s

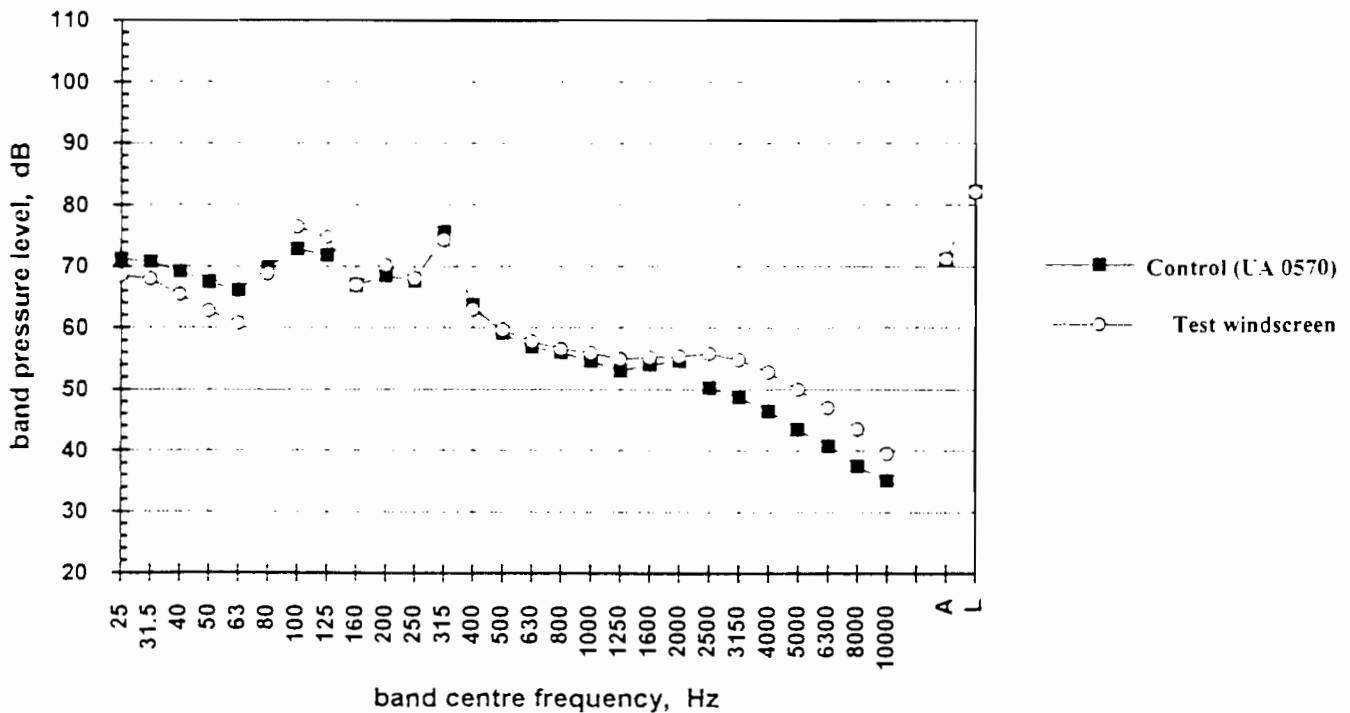

Figure 25 10 ppi hollow windscreen + UA 0237 -v- UA 0570 - smooth flow 10 m/

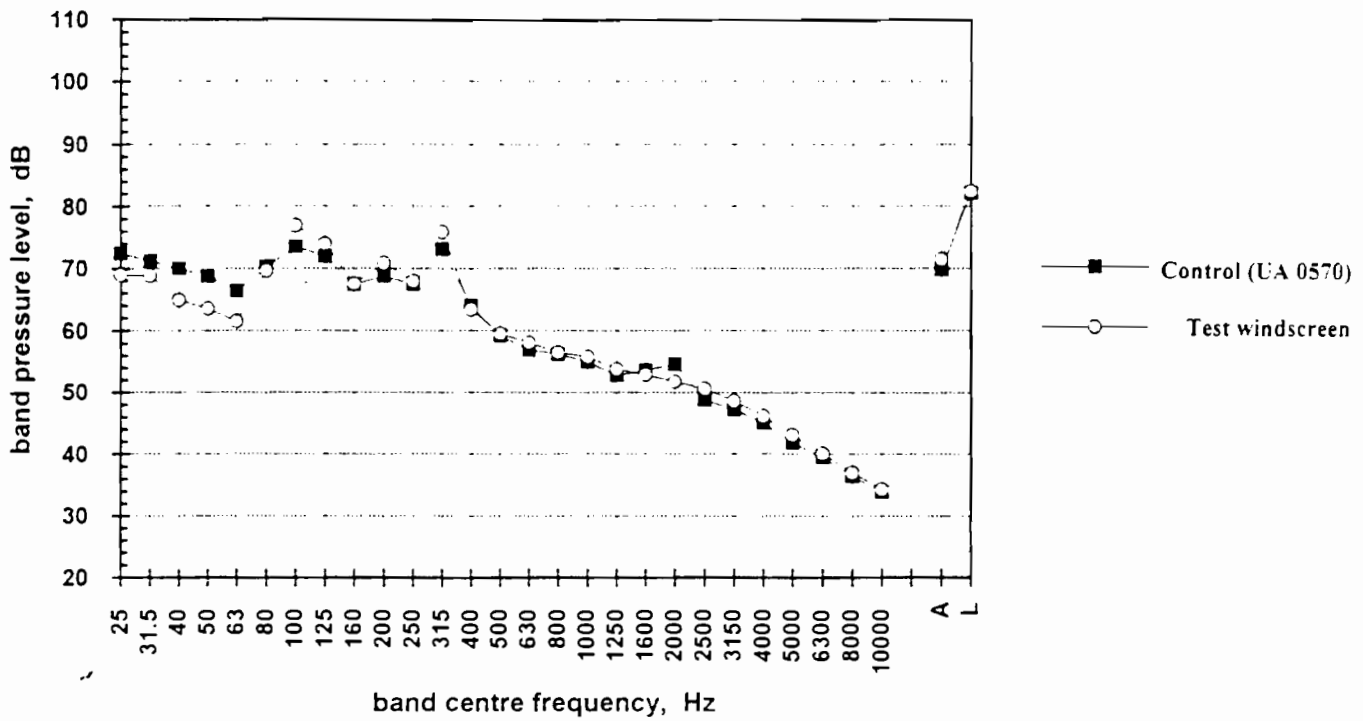

Figure 26 10 ppi solid windscreen -v-UA 0570 - smooth flow 10 m/s

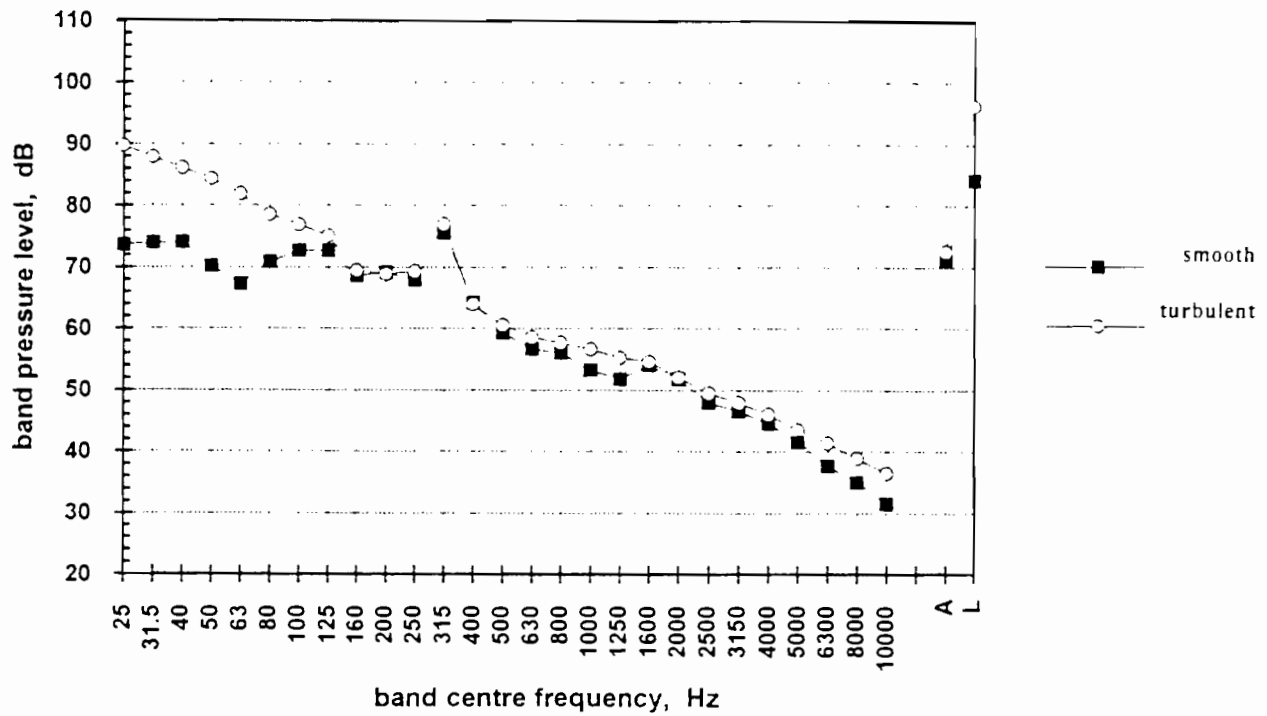

Figure 27 Control windscreen (UA 0570) in smooth and turbulent flow

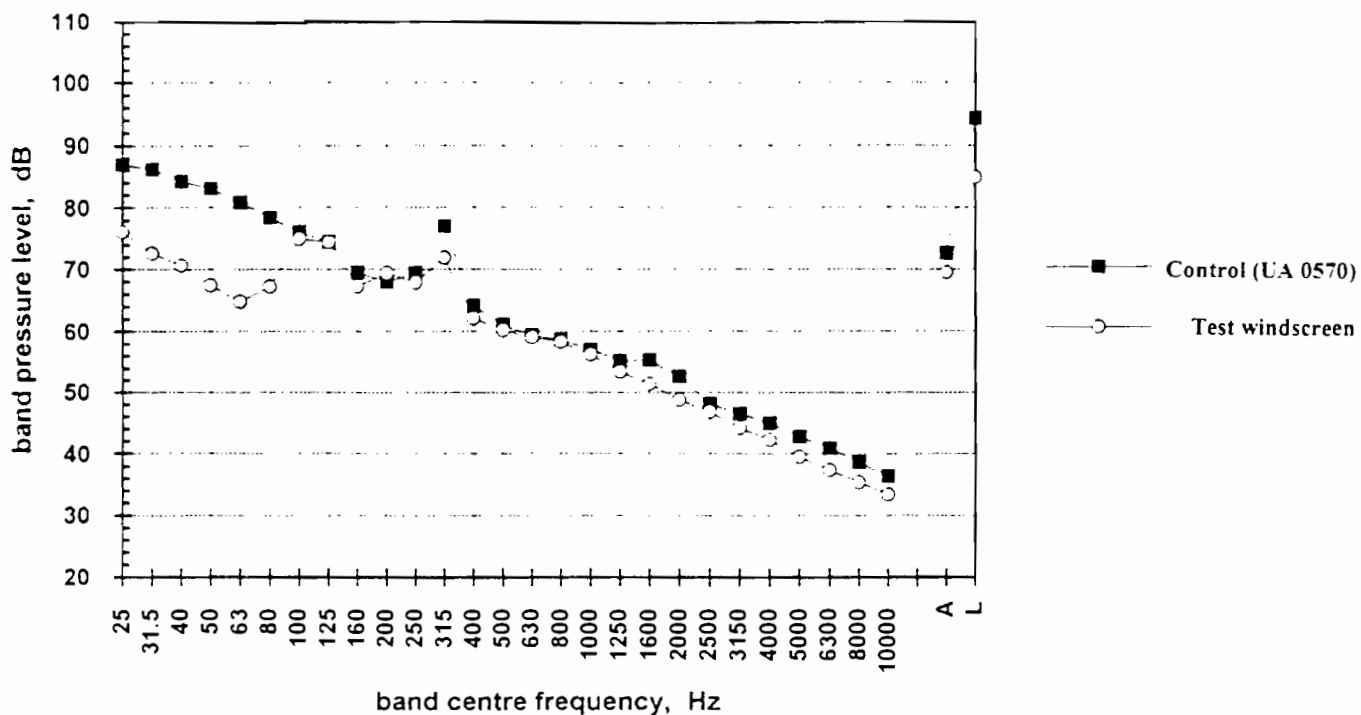

Figure 28 30 ppi hollow windscreen -v- UA 0570 - turbulent flow 10 m/s

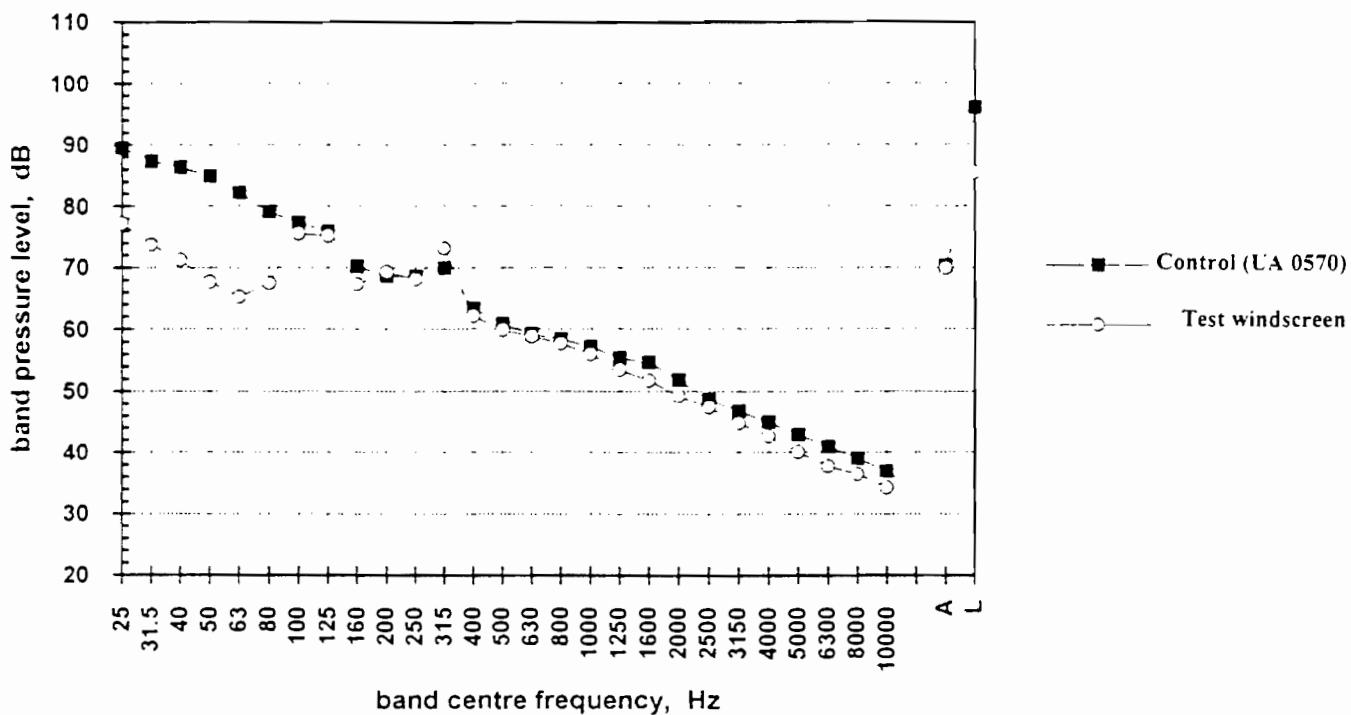

Figure 29 30 ppi hollow windscreen + UA 0237 -v- UA 0570 - turbulent flow

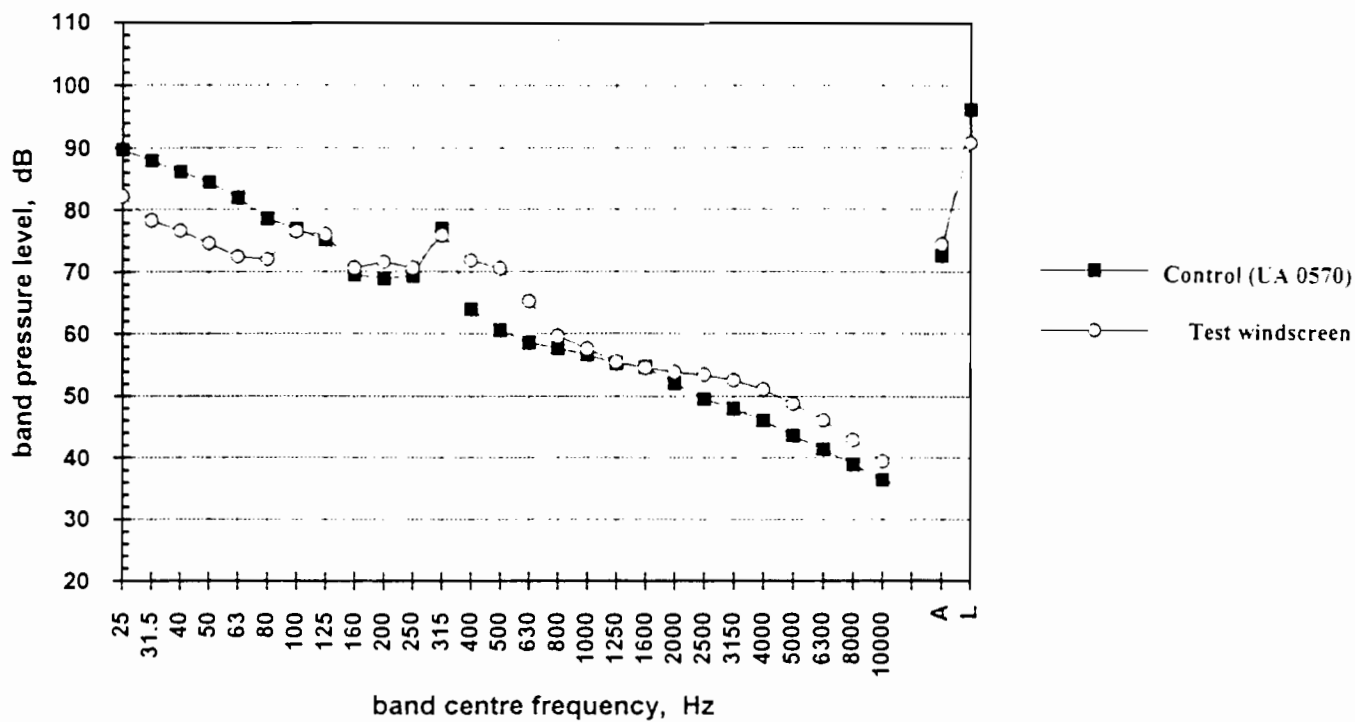

Figure 30 10 ppi hollow windscreen -v- UA 0570 - turbulent flow 10 m/s

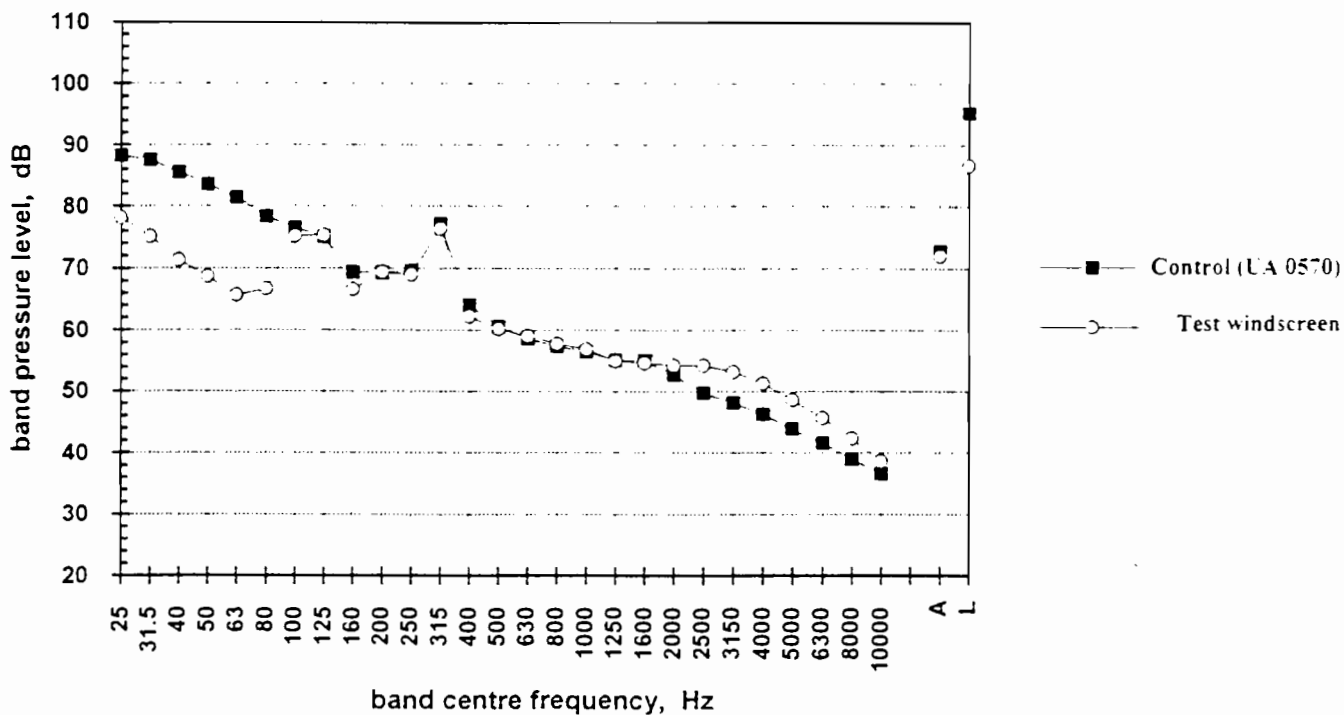

Figure 31 10 ppi hollow windscreen + UA 0237 -v- UA 0570 - turbulent flow

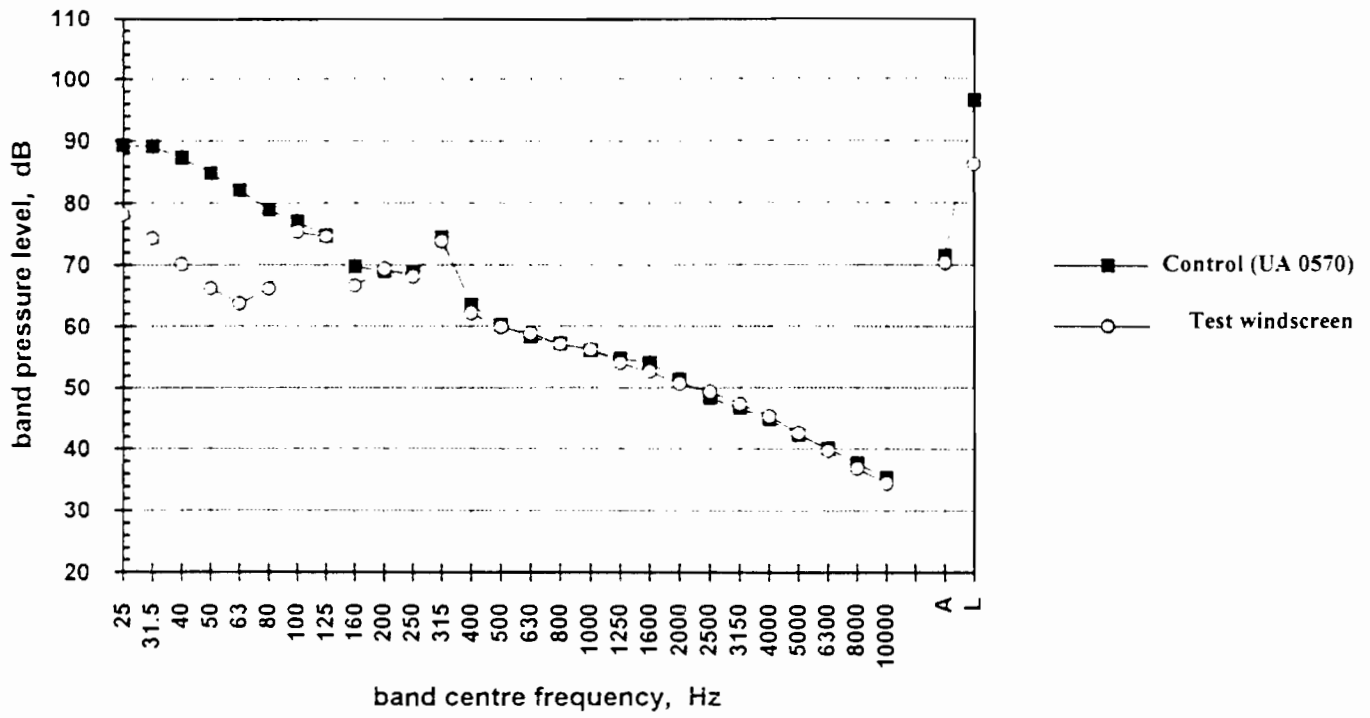

Figure 32 10 ppi solid windscreen -v- UA 0570 - turbulent flow 10 m/s

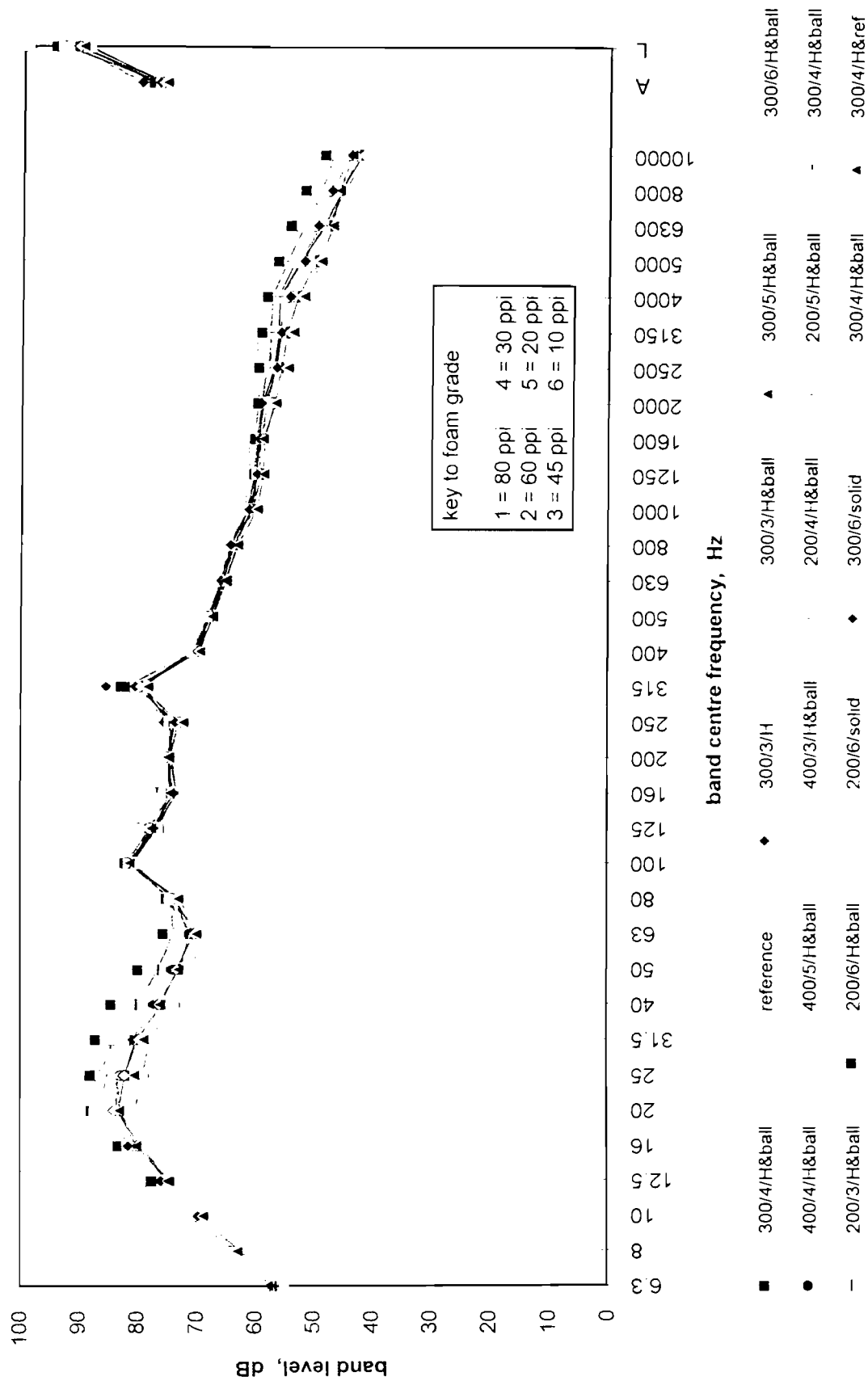

Figure 33 Wind tunnel tests (10 ms). Comparative one-third octave band spectra for test and control windscreens

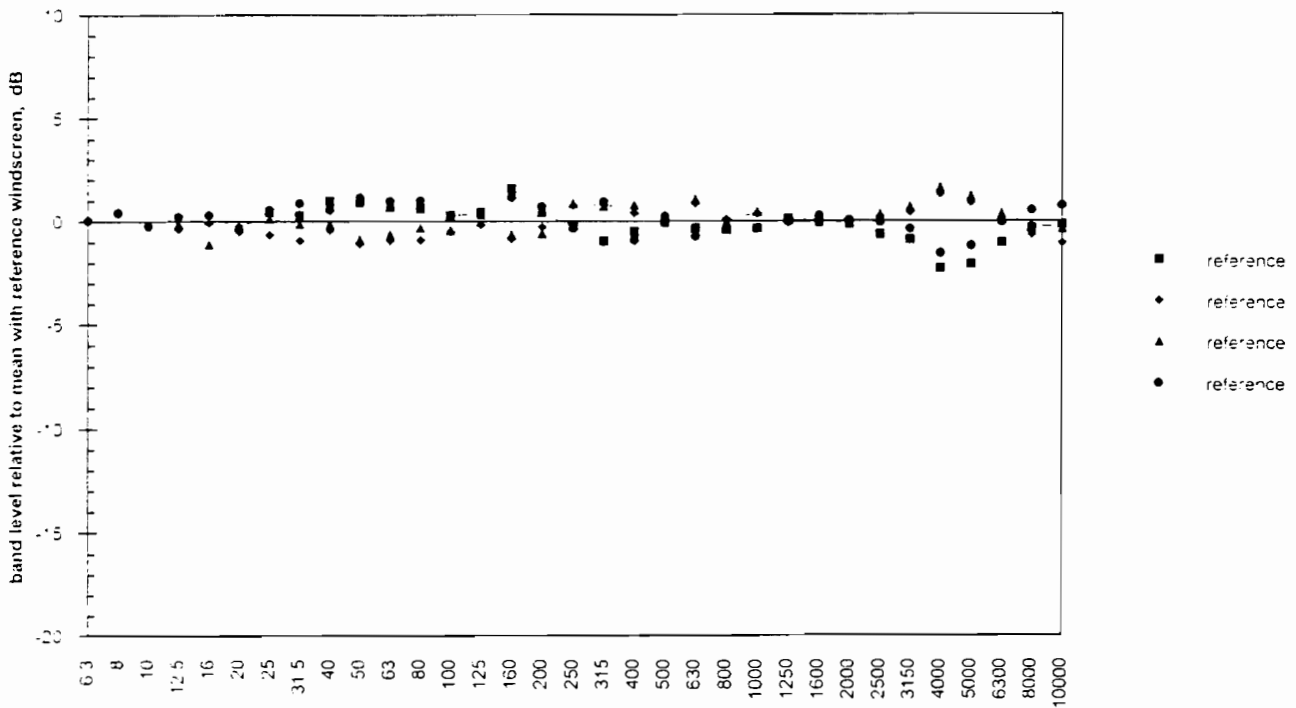
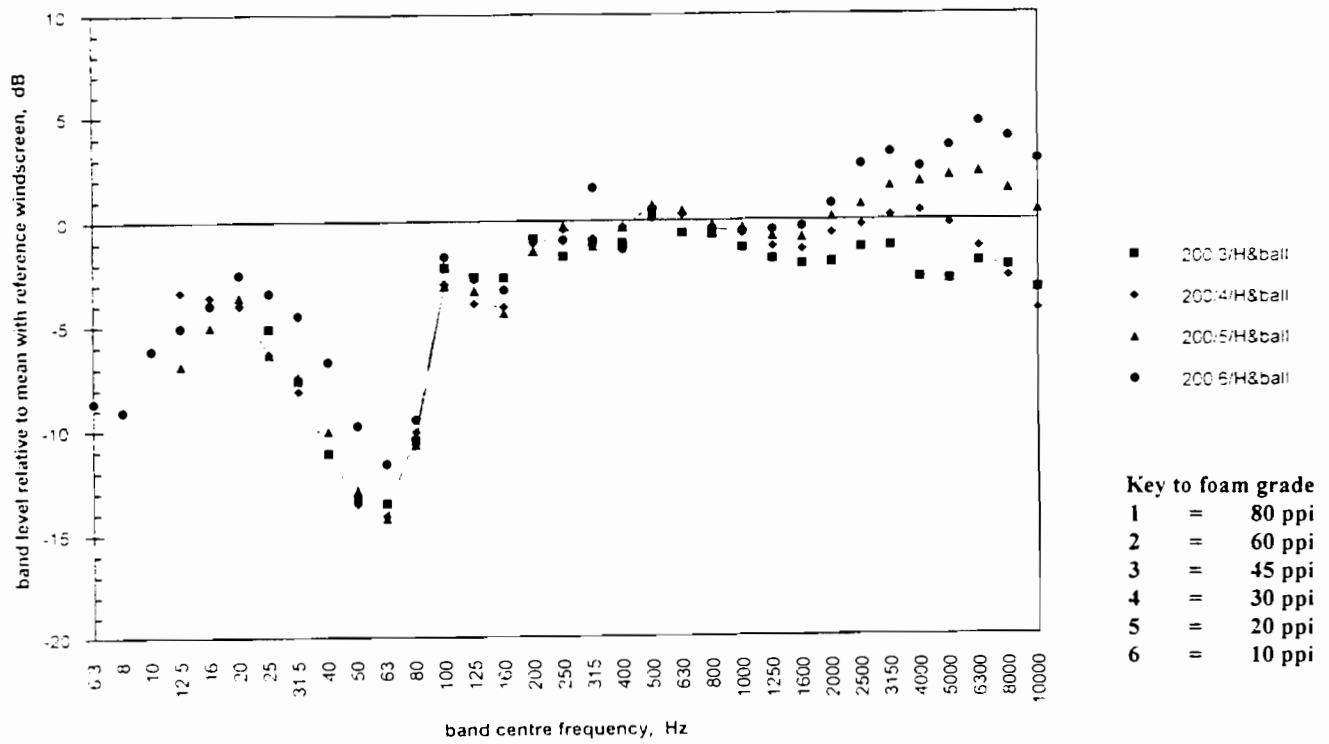
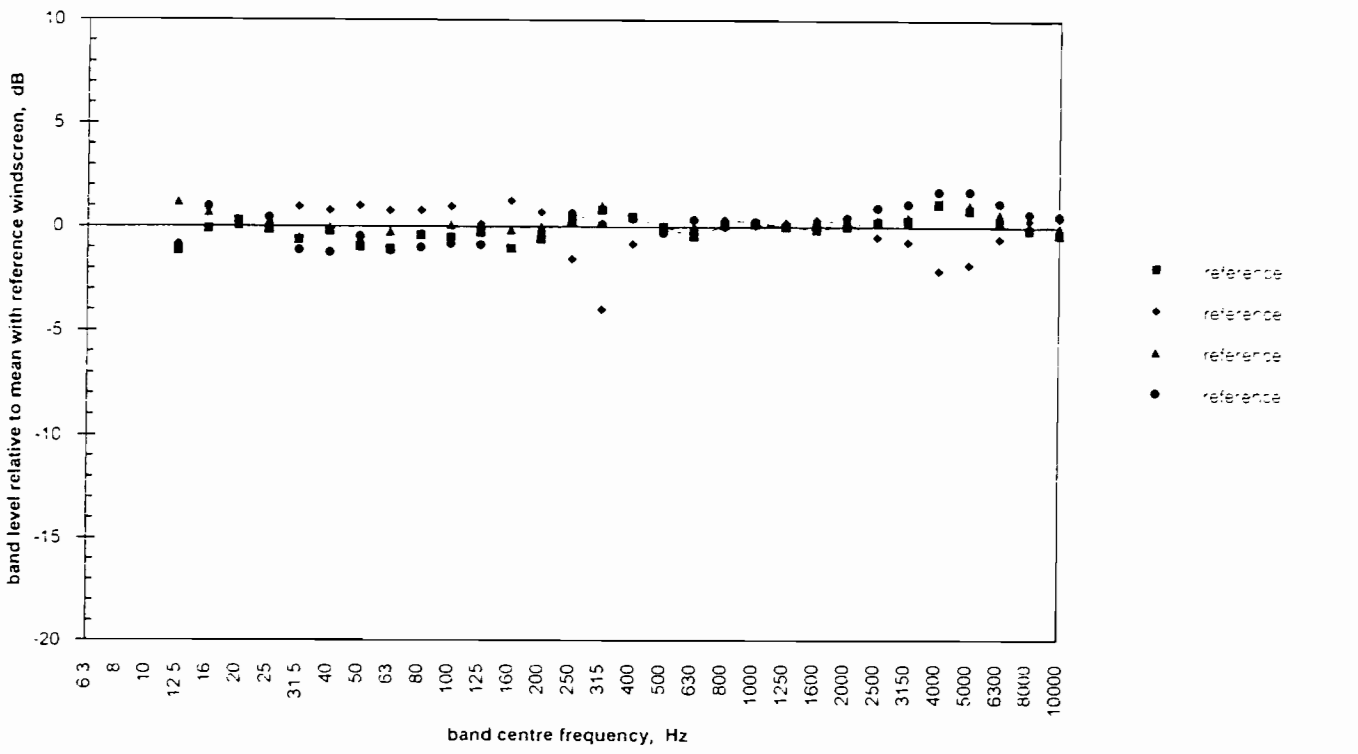
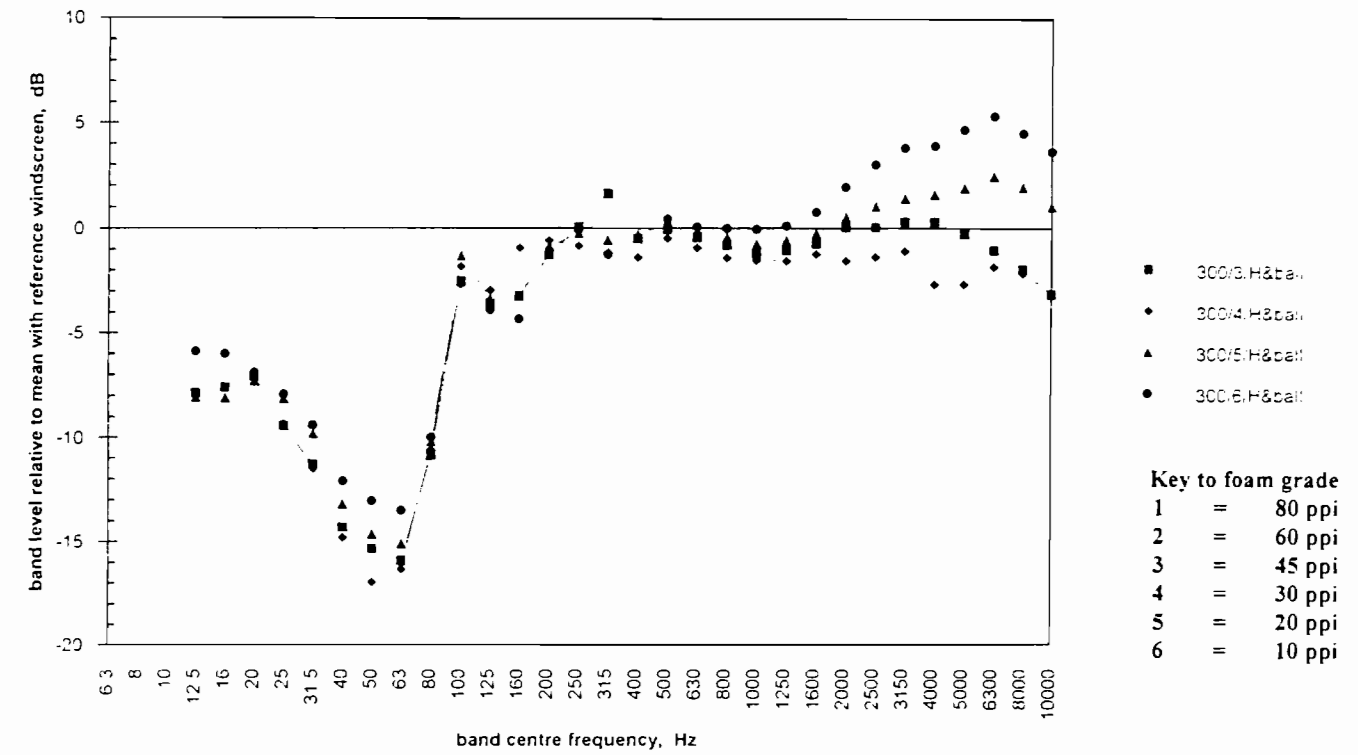

Figure 34 One-third octave band SPL/s relative to control windscreen (10 m/s)
Two layer windscreens. 200 mm/45-30-20-10 ppi



**Figure 35 One-third octave band SPL/s relative to control windscreen (10 m/s)
Two layer windscreens. 300 mm/45-30-20-10 ppi**

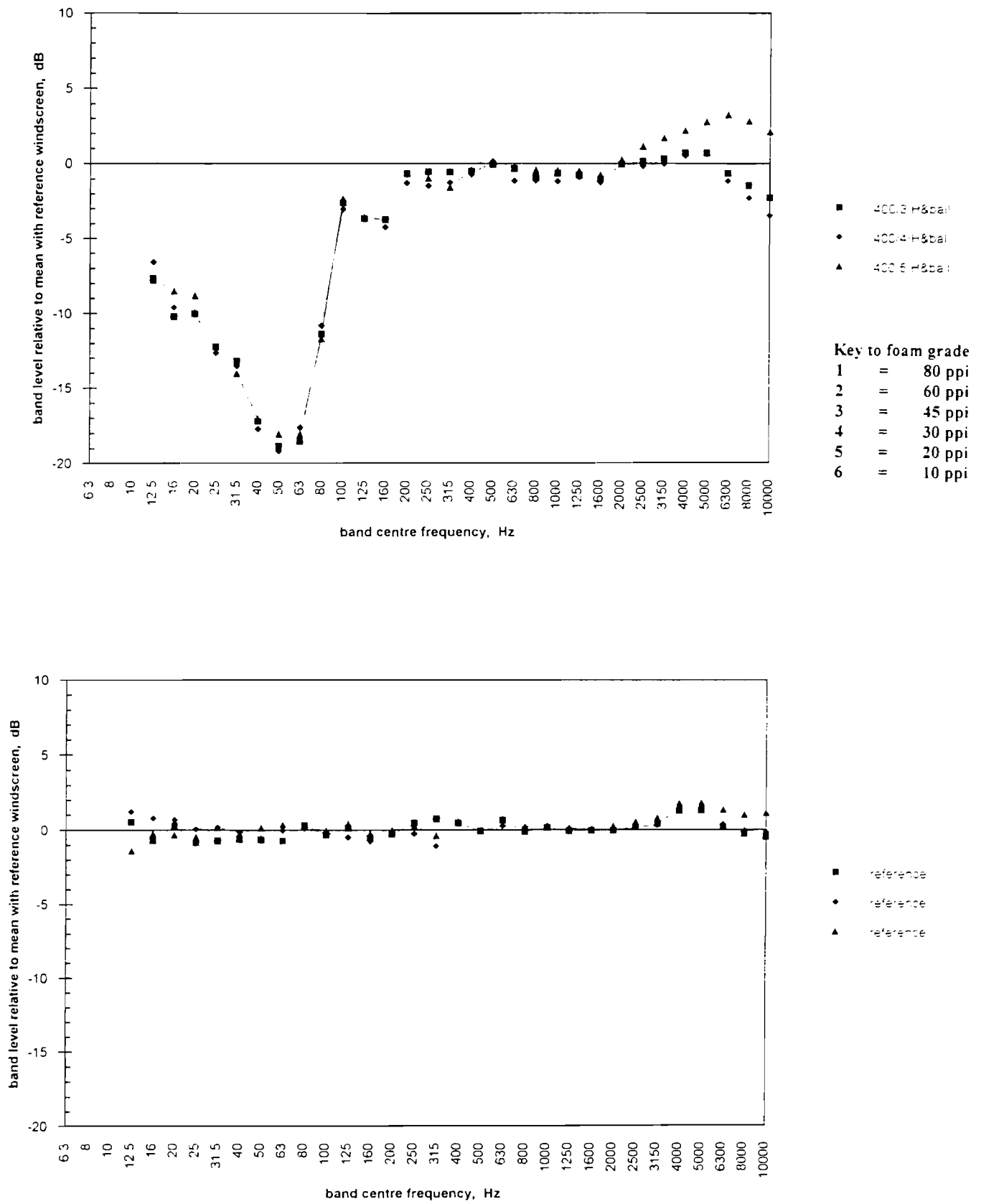

Figure 36 One-third octave band SPL/s relative to control windscreen (10 m/s)
Two layer windscreens. 400 mm/45-30-20 ppi

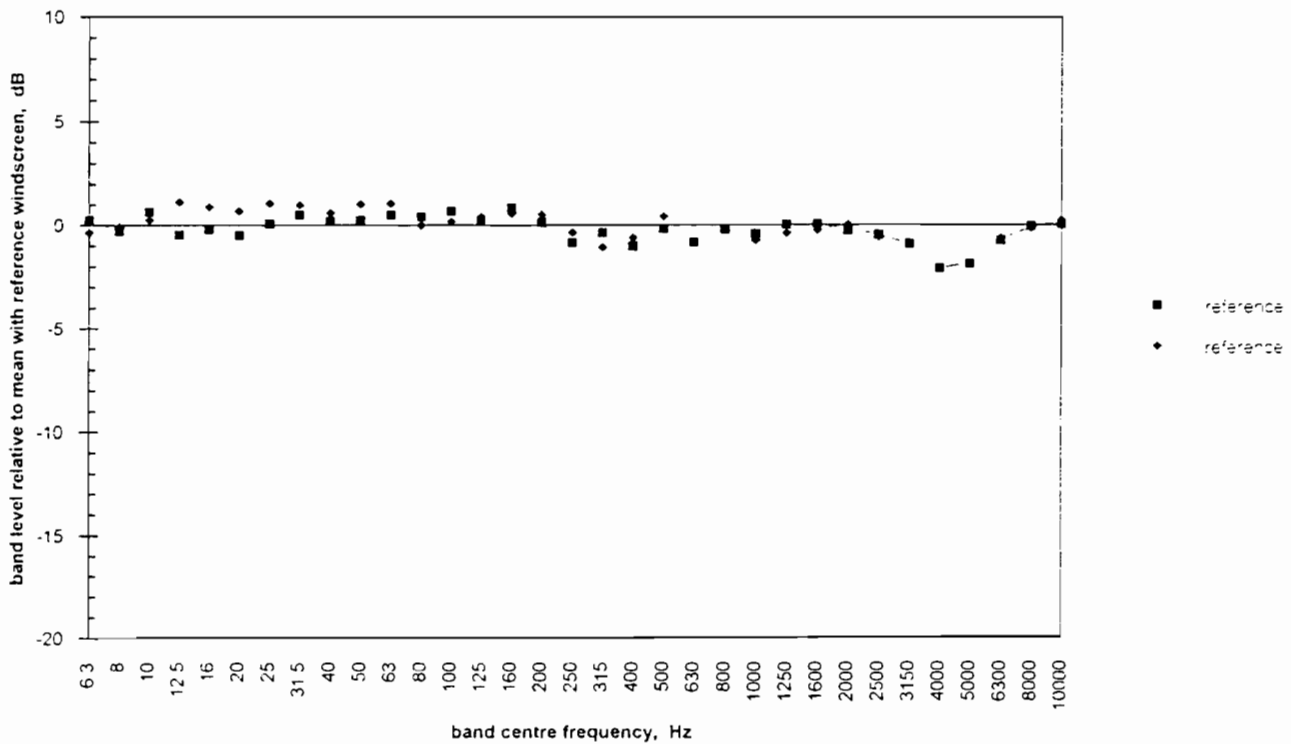
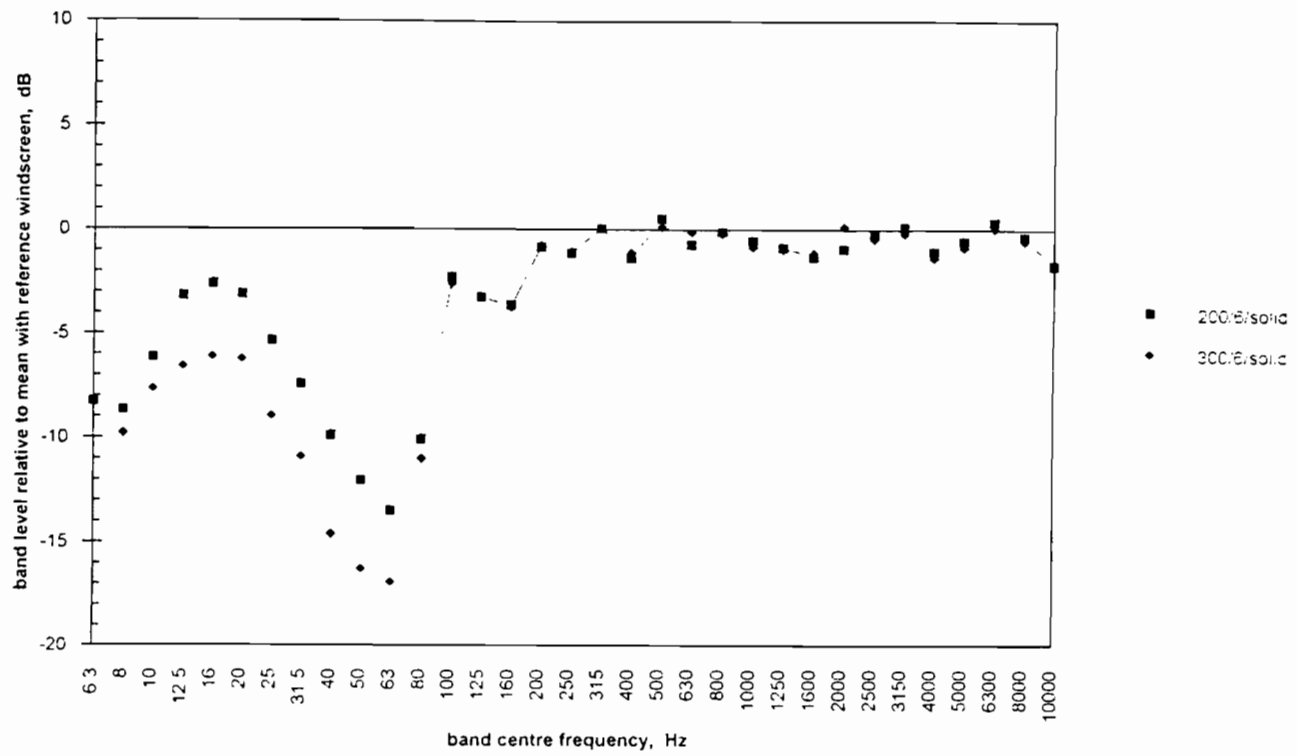

Figure 37 One-third octave band SPL's relative to control windscreen (10 m/s)
200 mm/10 ppi -v-300 mm/10 ppi windscreen

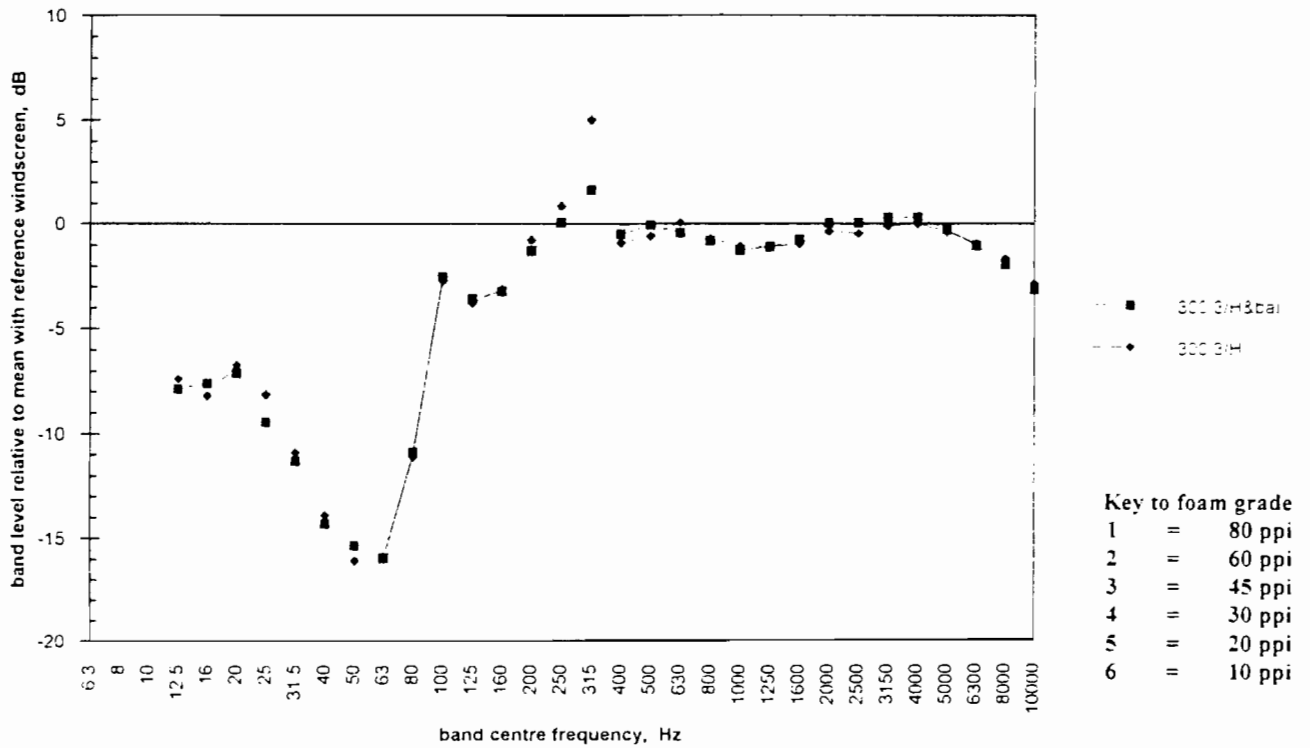

Figure 38 One-third octave band SPL/s relative to control windscreen (10 m/s)
 300 mm/45 ppi two-layer -v- 300 mm/45 ppi single layer windscreens

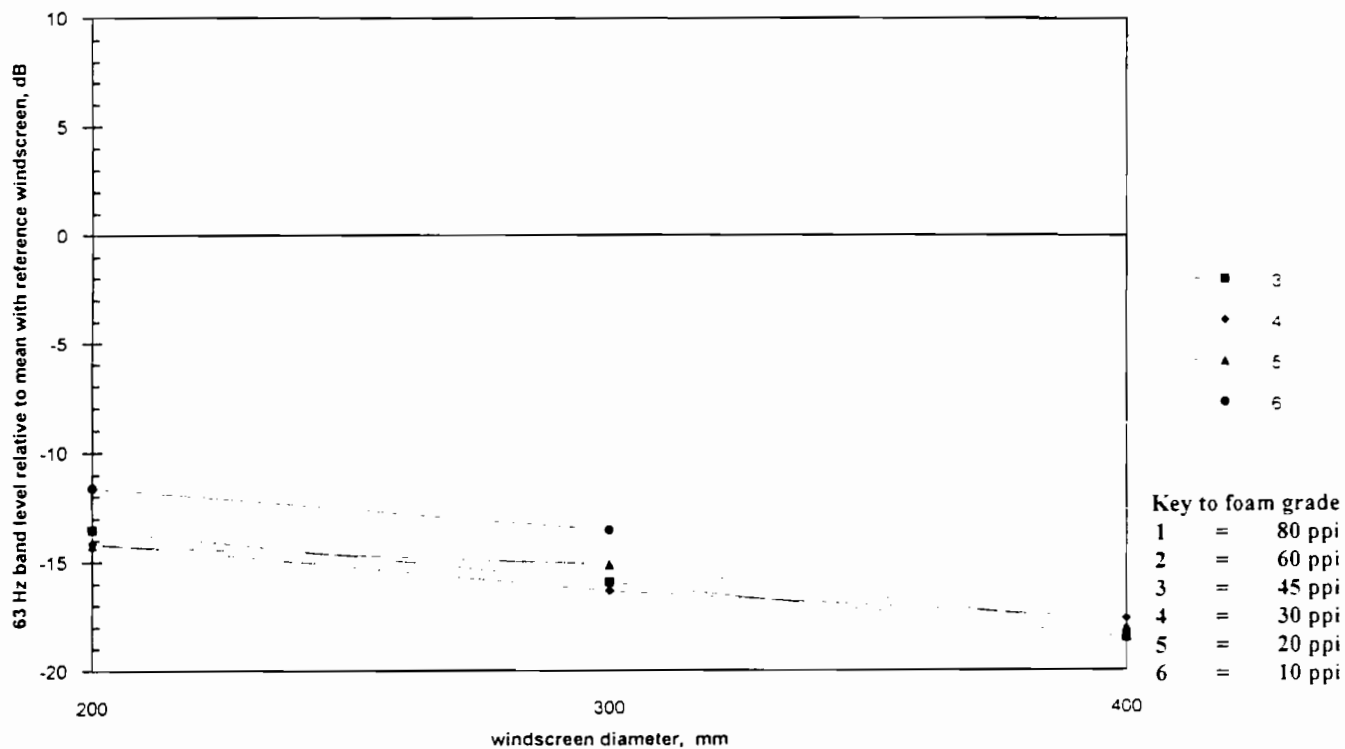

Figure 39 Two layer windscreens, 10 m/s.
SPL in 63 Hz band -v- foam grade, different diameters

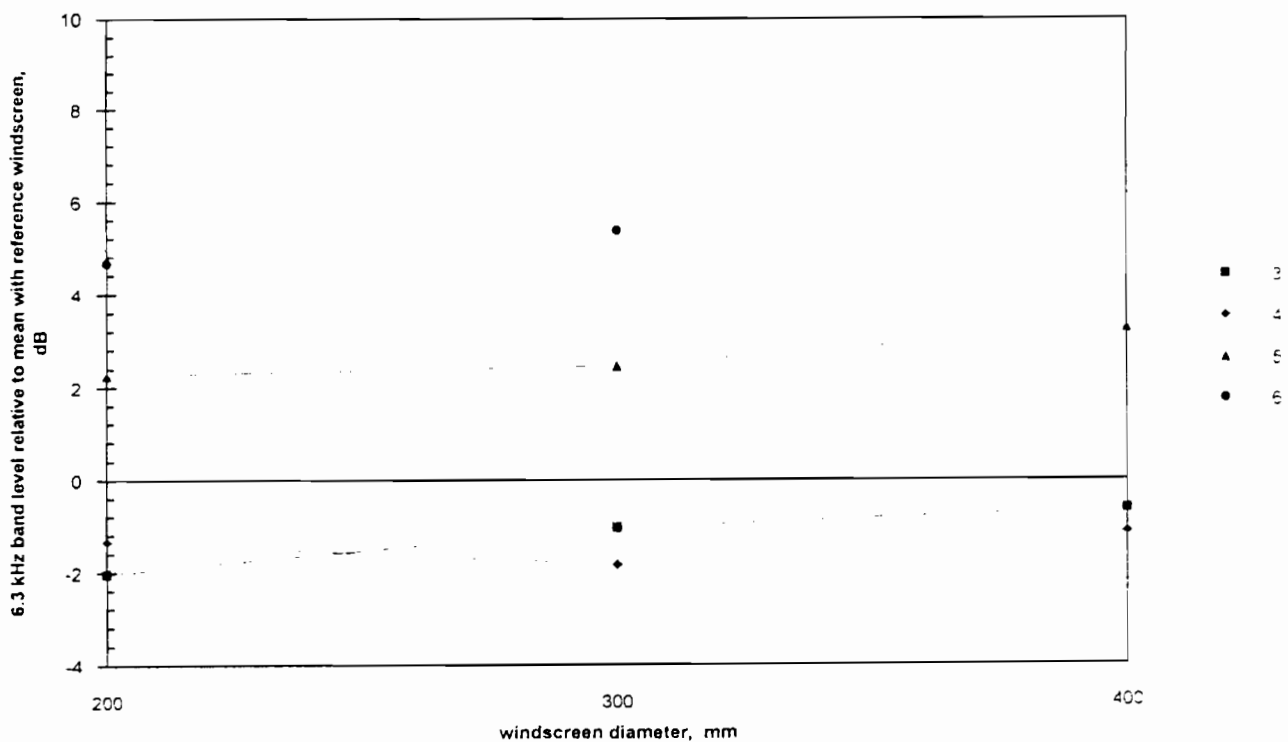

Figure 40 Two layer windscreens, 10 m/s.
SPL in 6.3 kHz band -v- foam grade, different diameters

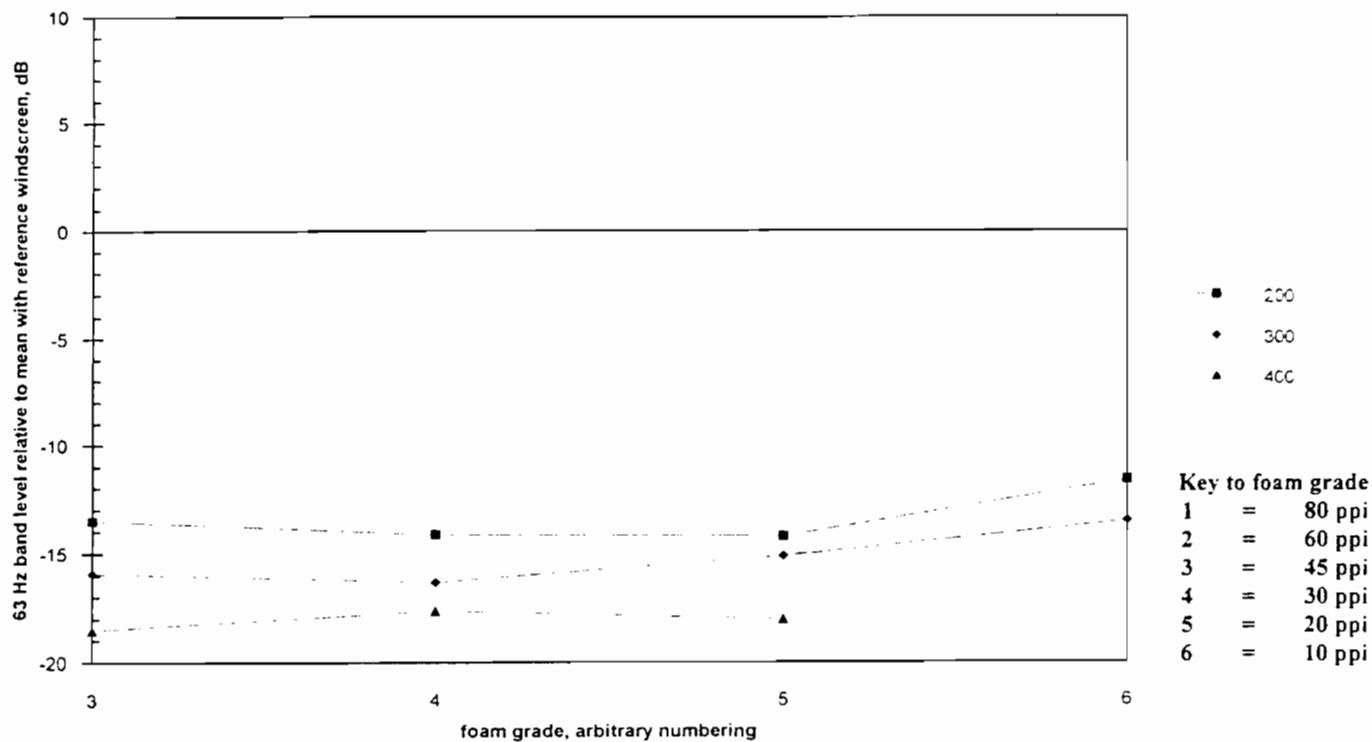

Figure 41 Two layer windscreens, 10 m/s.
SPL in 63 Hz band -v- foam grade, different diameters

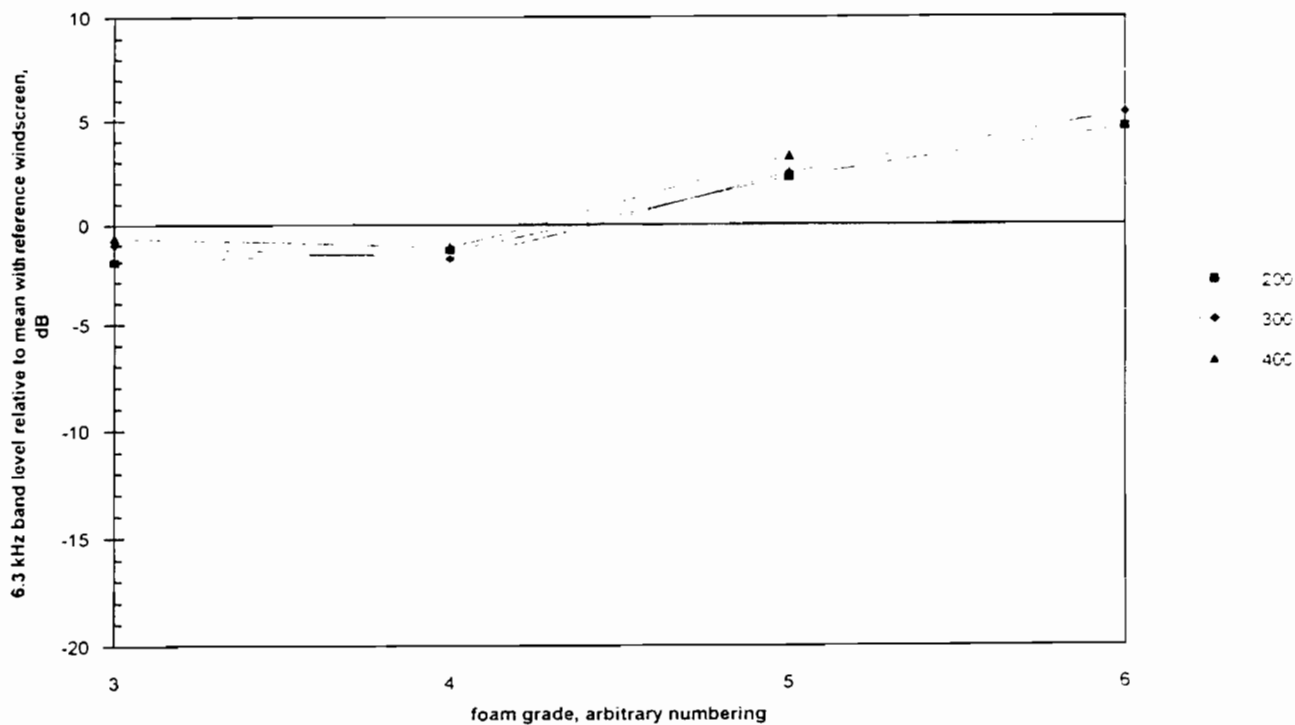

Figure 42 Two layer windscreens, 10 m/s.
SPL in 6.3 kHz band -v- foam grade, different diameters

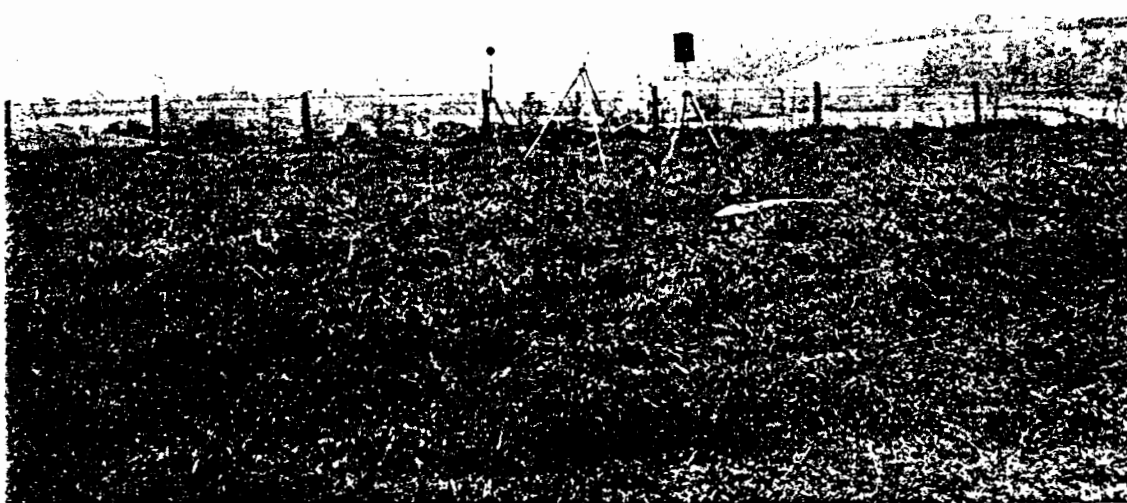
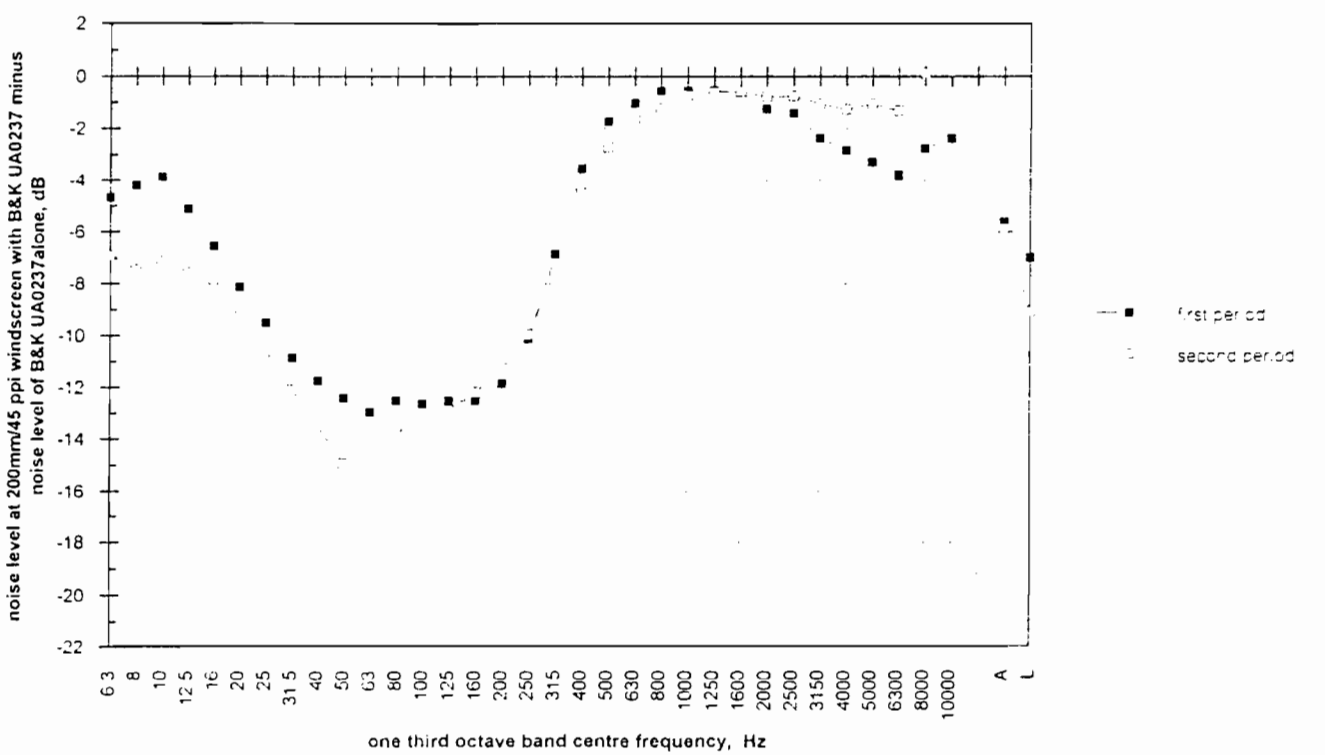
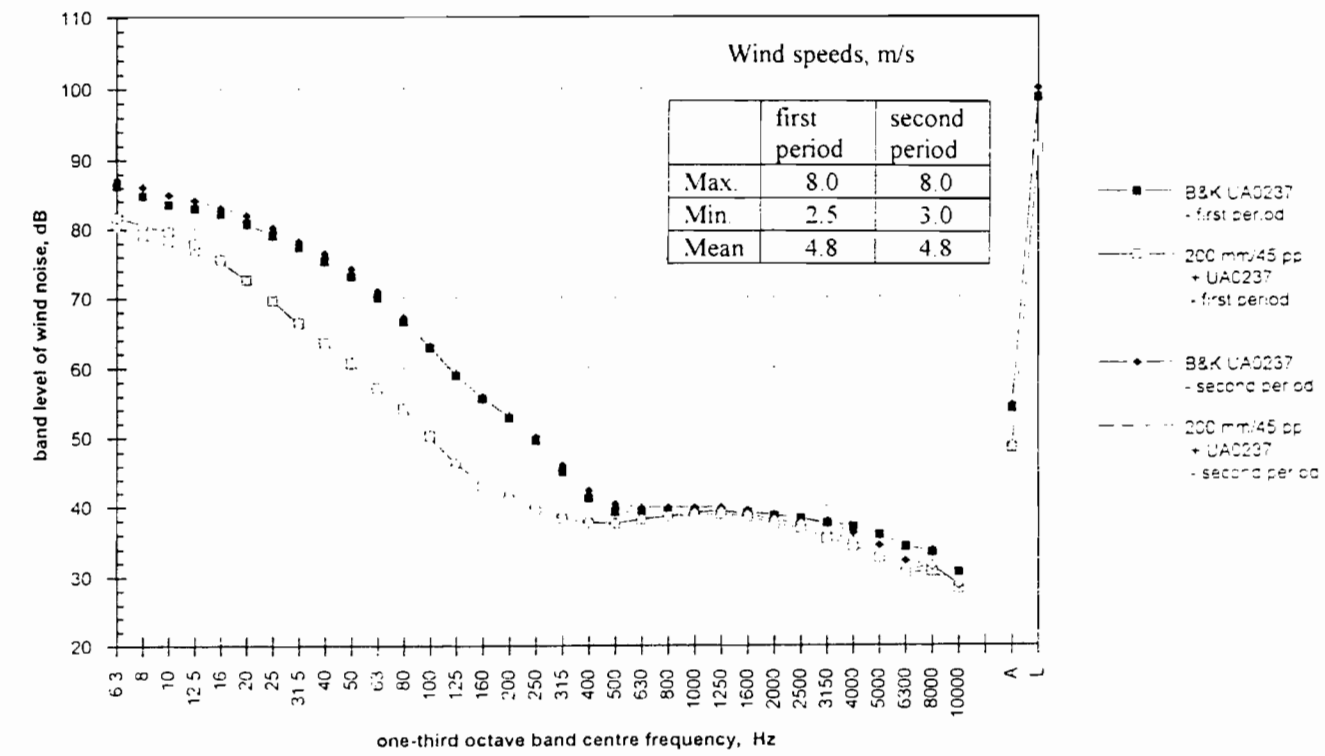
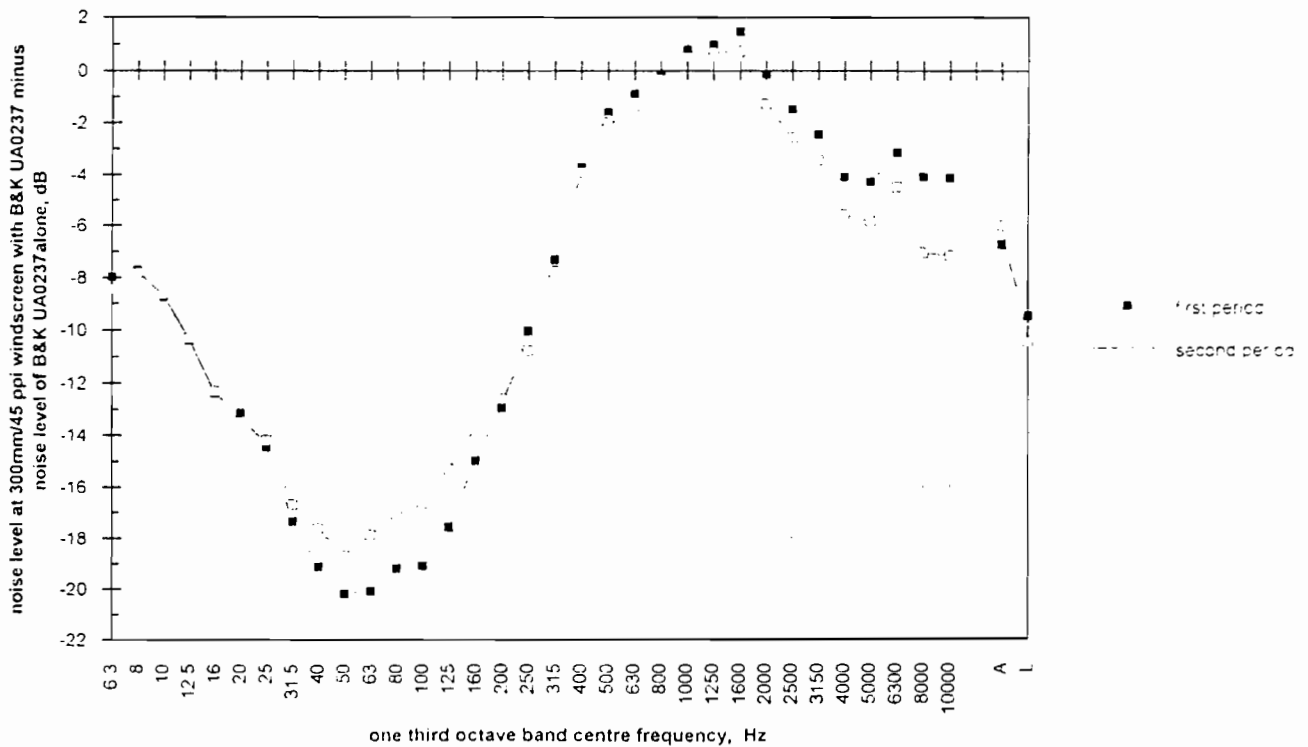
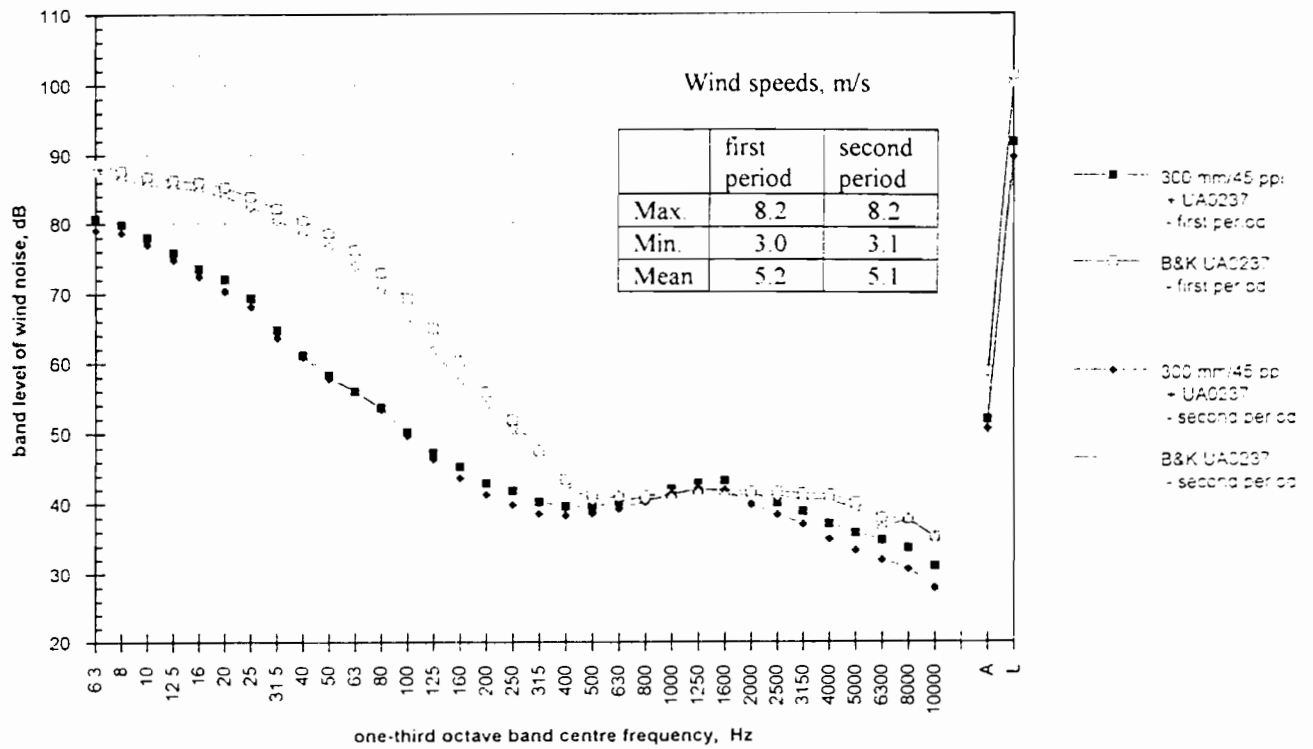

Figure 43 Test set up - Farley Mount (looking South)



**Figure 44 Comparative noise spectra.
200 mm/45 ppi -v- UA 0237 windscreens**



**Figure 45 Comparative noise spectra.
300 mm/45 ppi -v- UA 0237 windscreens**

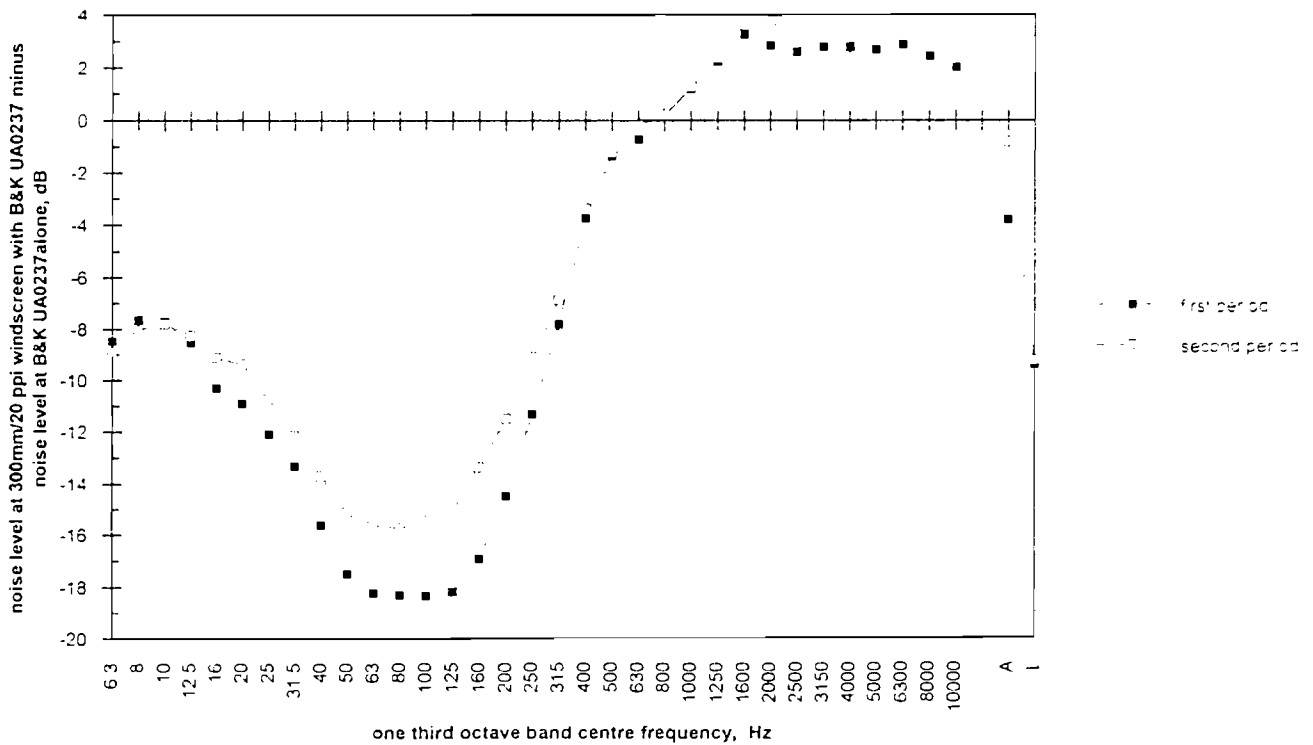
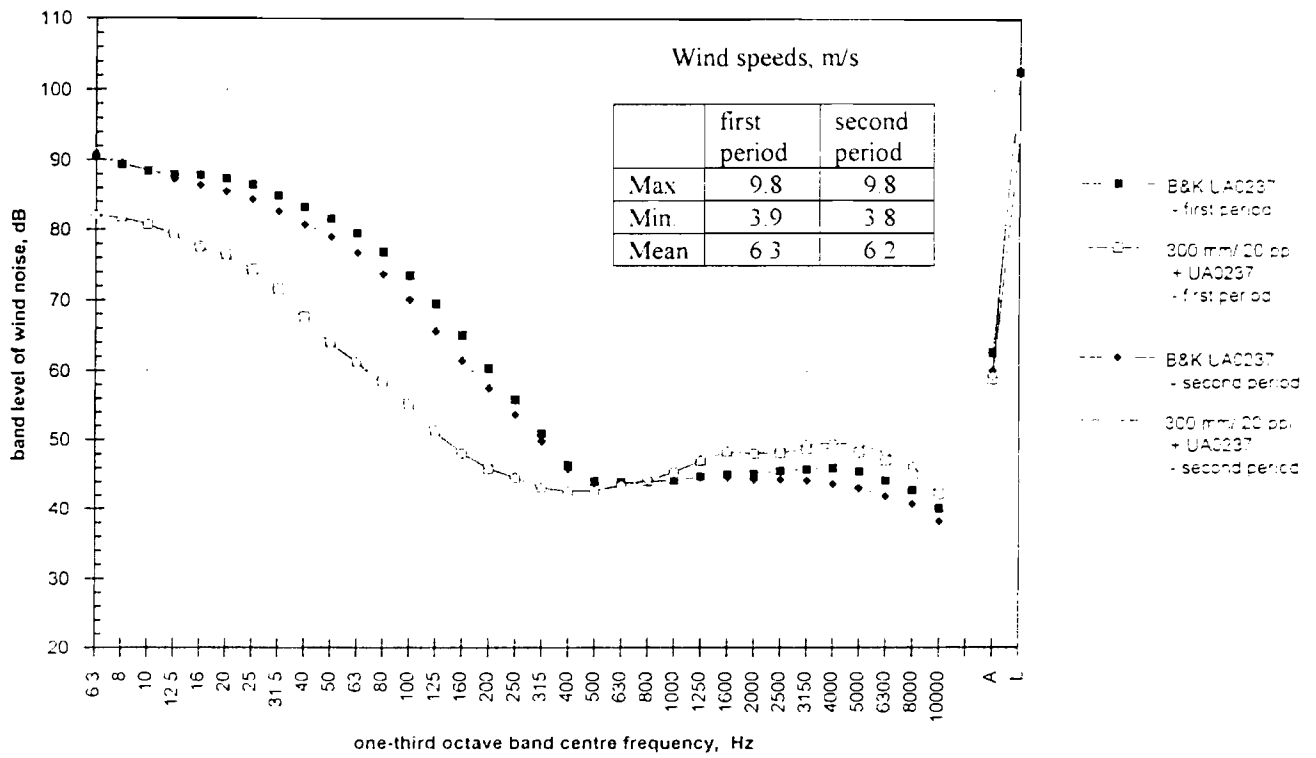

Figure 46 Comparative noise spectra.
300 mm/20 ppi -v- UA 0237 windscreens

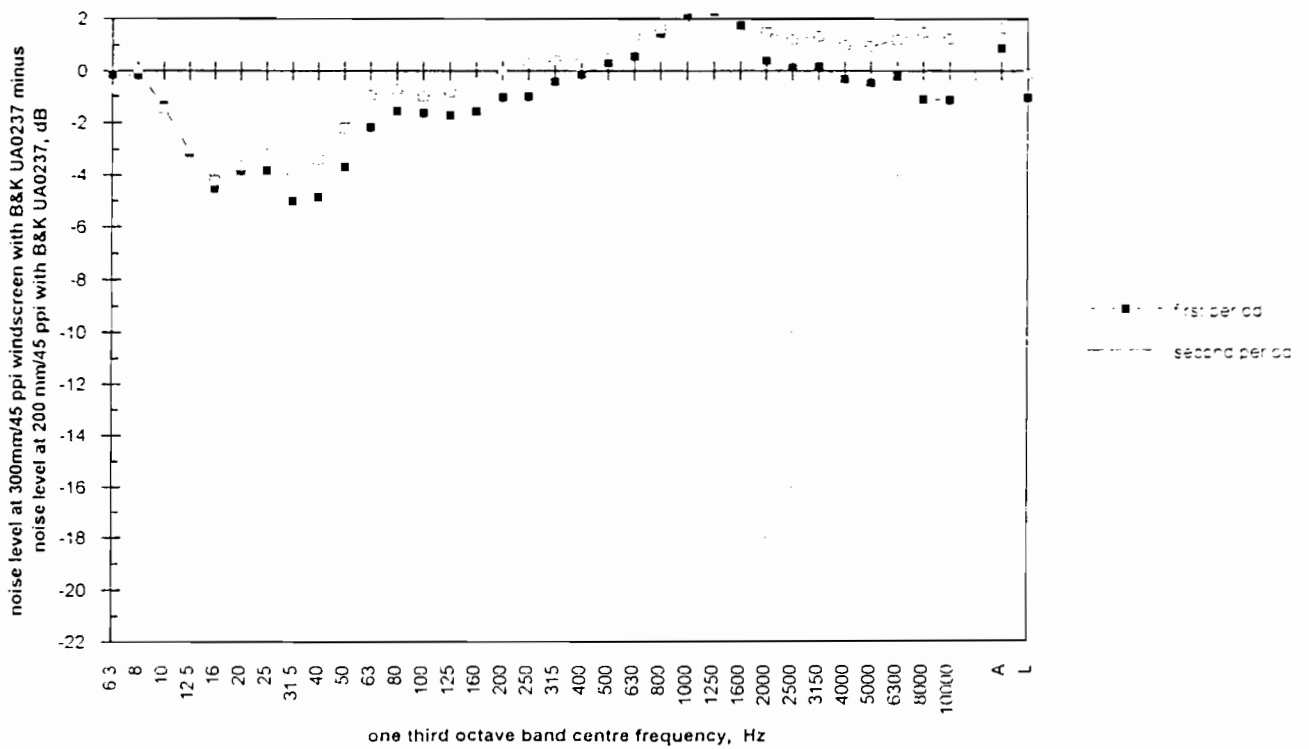
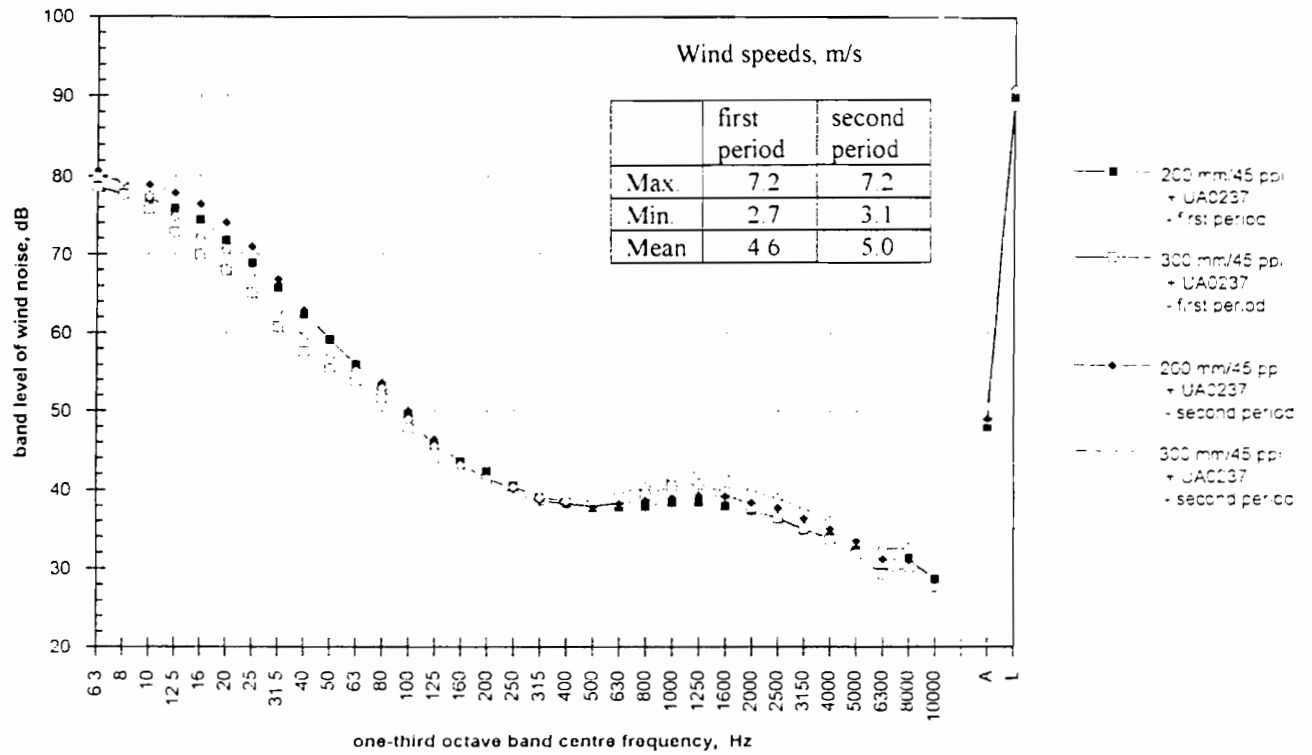
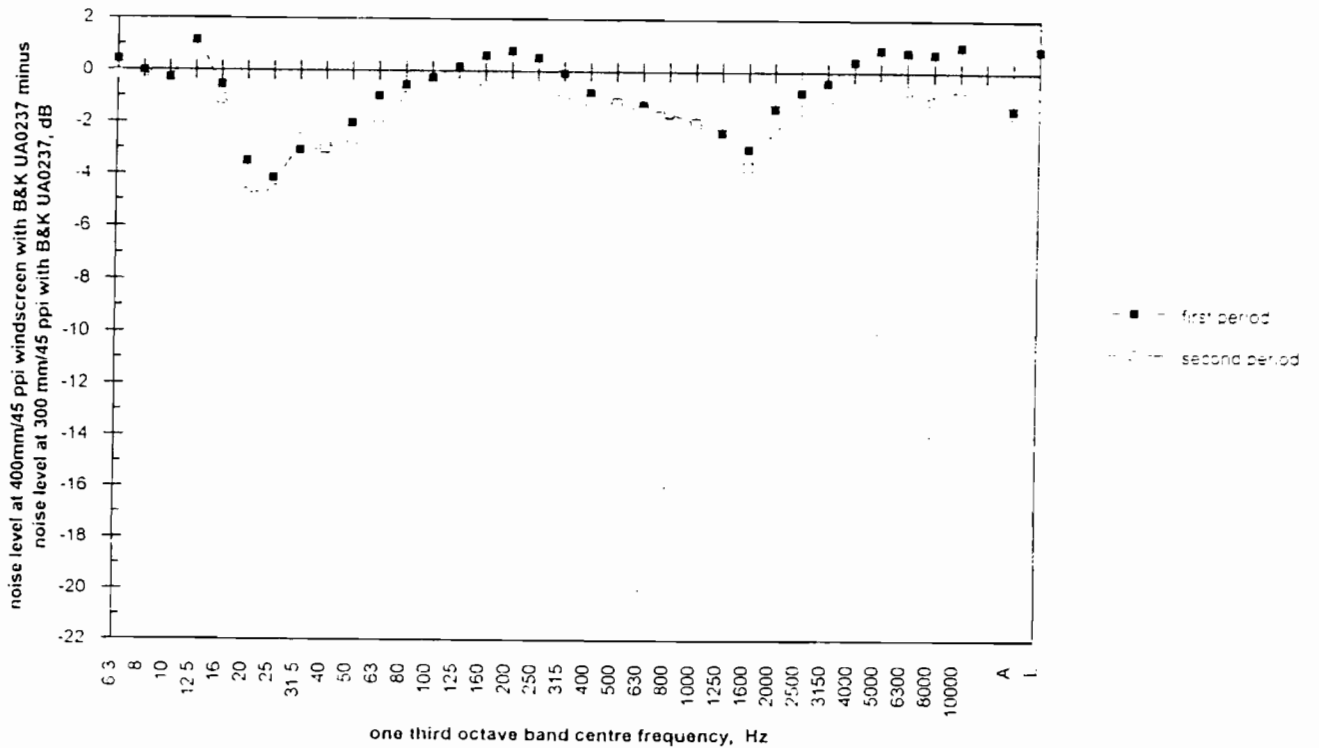
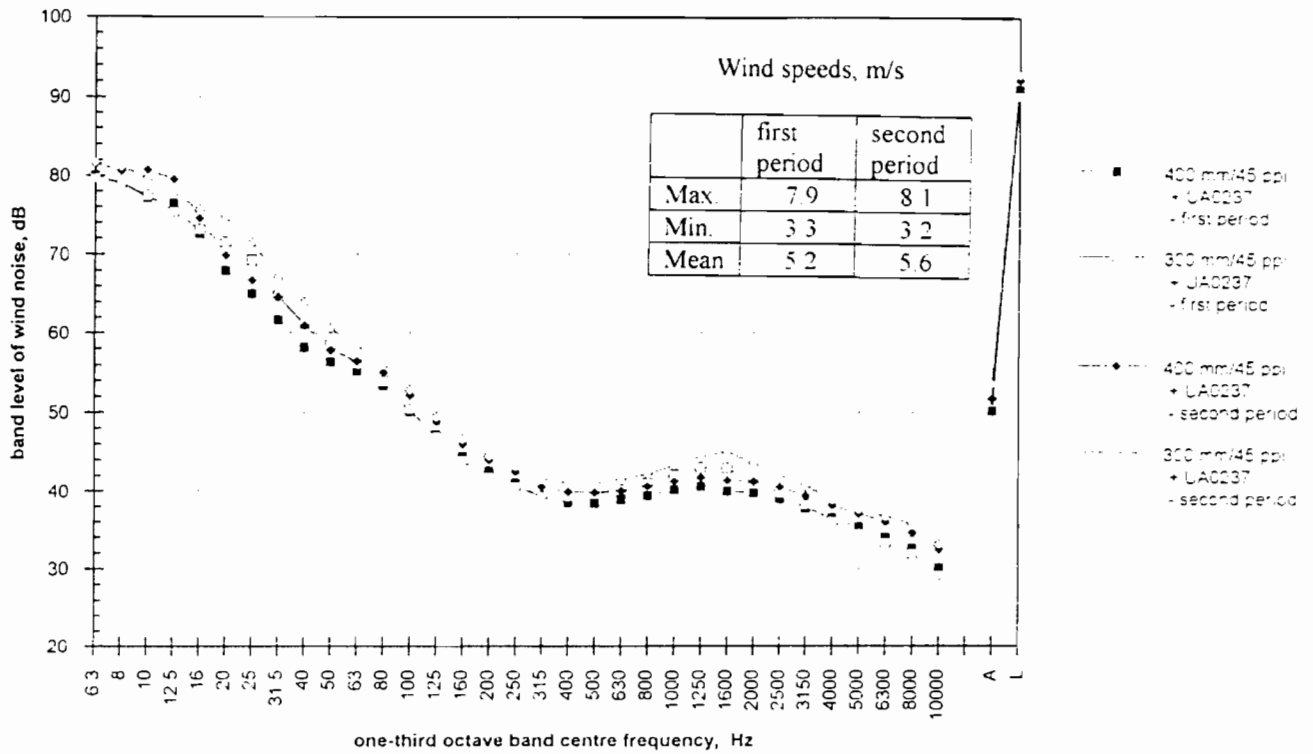
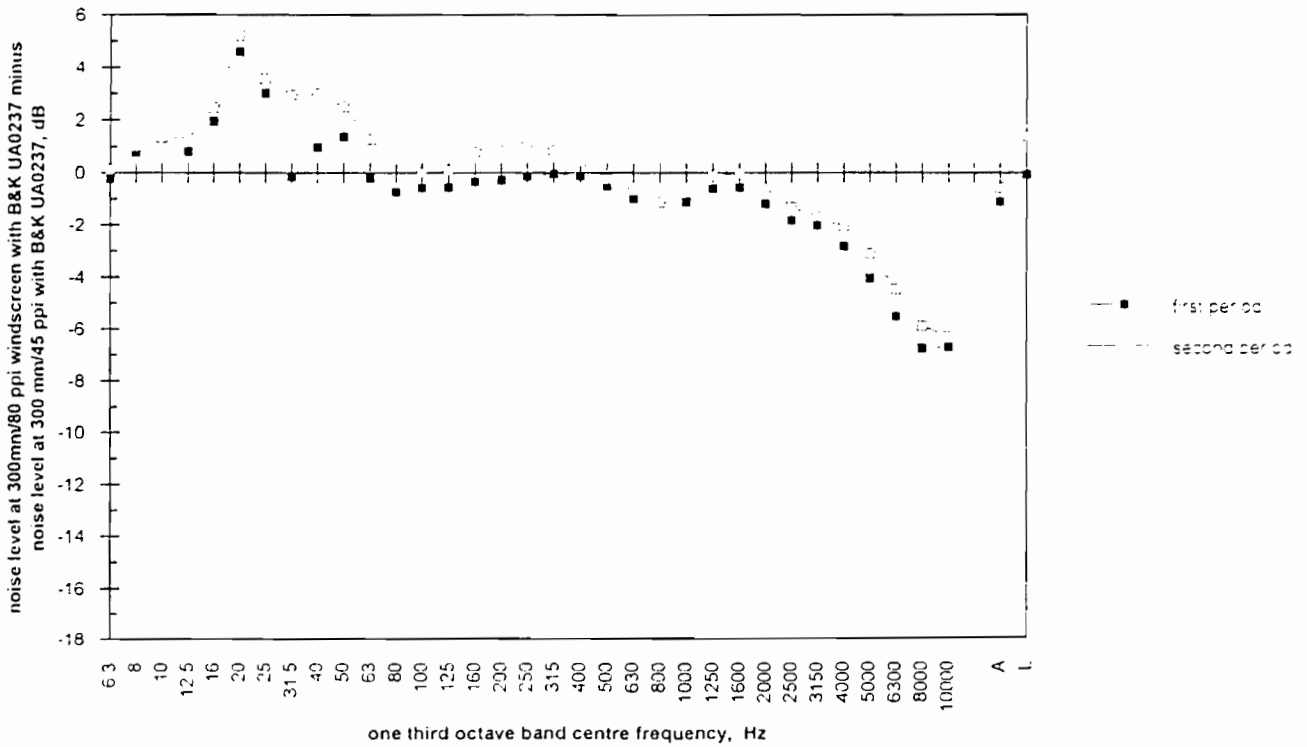
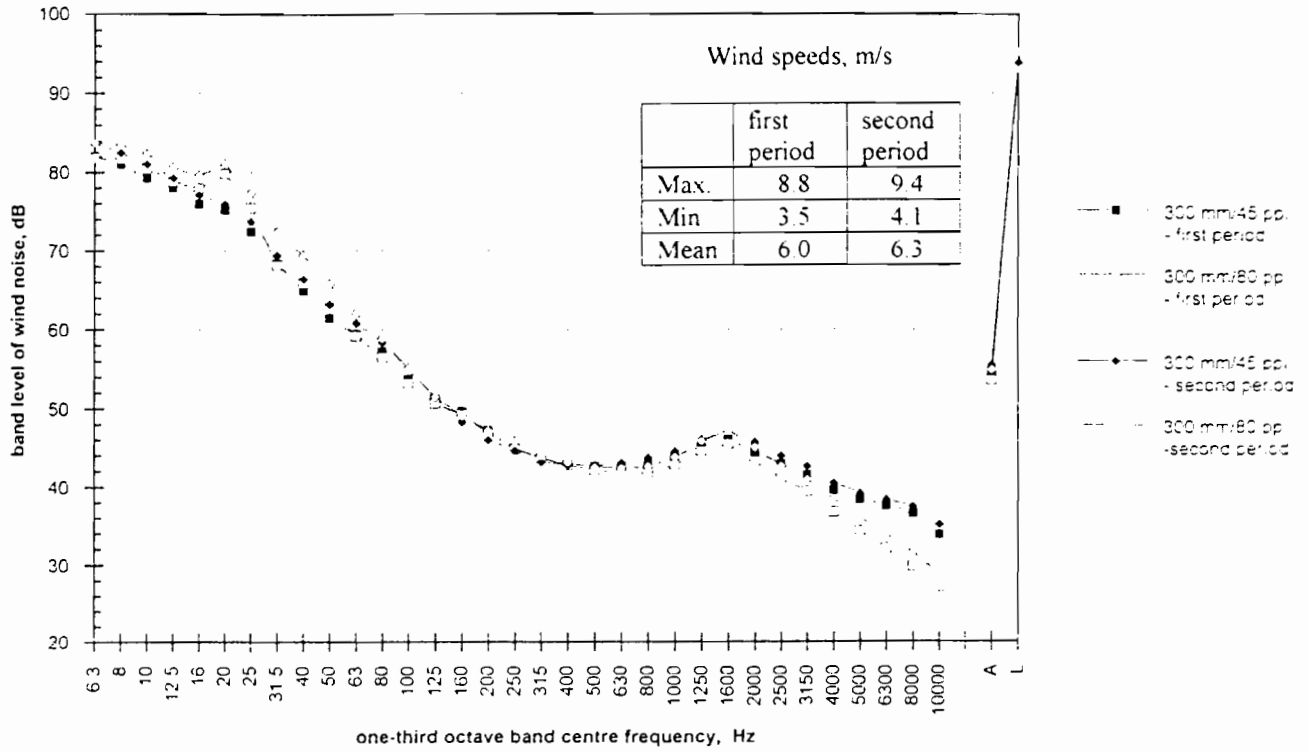

Figure 47 Comparative noise spectra.
200 mm/45 ppi -v- 300 mm/45 ppi windscreens



**Figure 48 Comparative noise spectra.
300 mm/45 ppi -v- 400 mm/45 ppi windscreens**



**Figure 49 Comparative noise spectra.
300 mm/45 ppi -v- 300 mm/80 ppi windscreens**

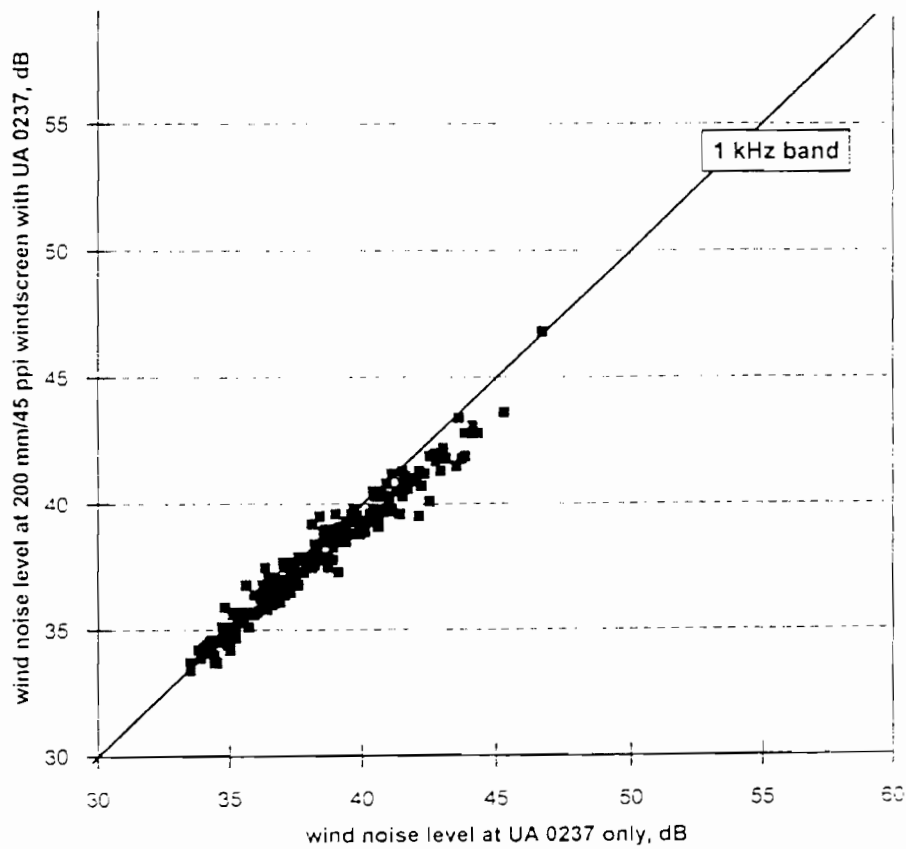
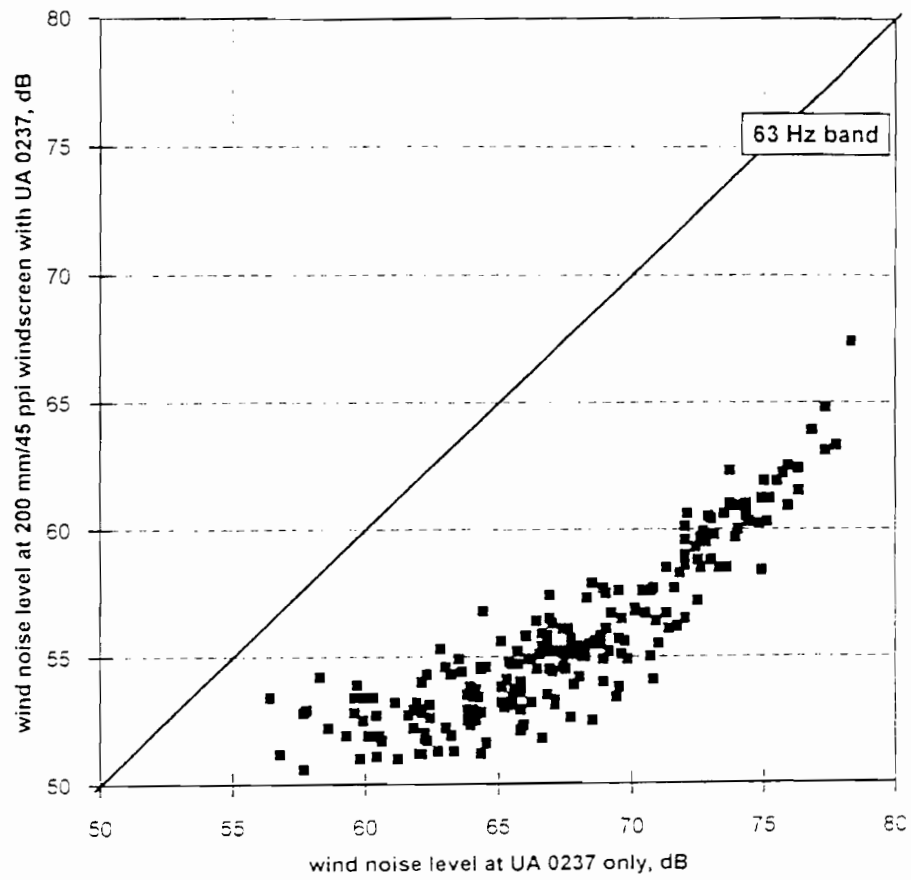

Figure 50 SPL in 63 Hz and 1 kHz bands plotted for 200 mm/45 ppi and UA 0237 windscreens

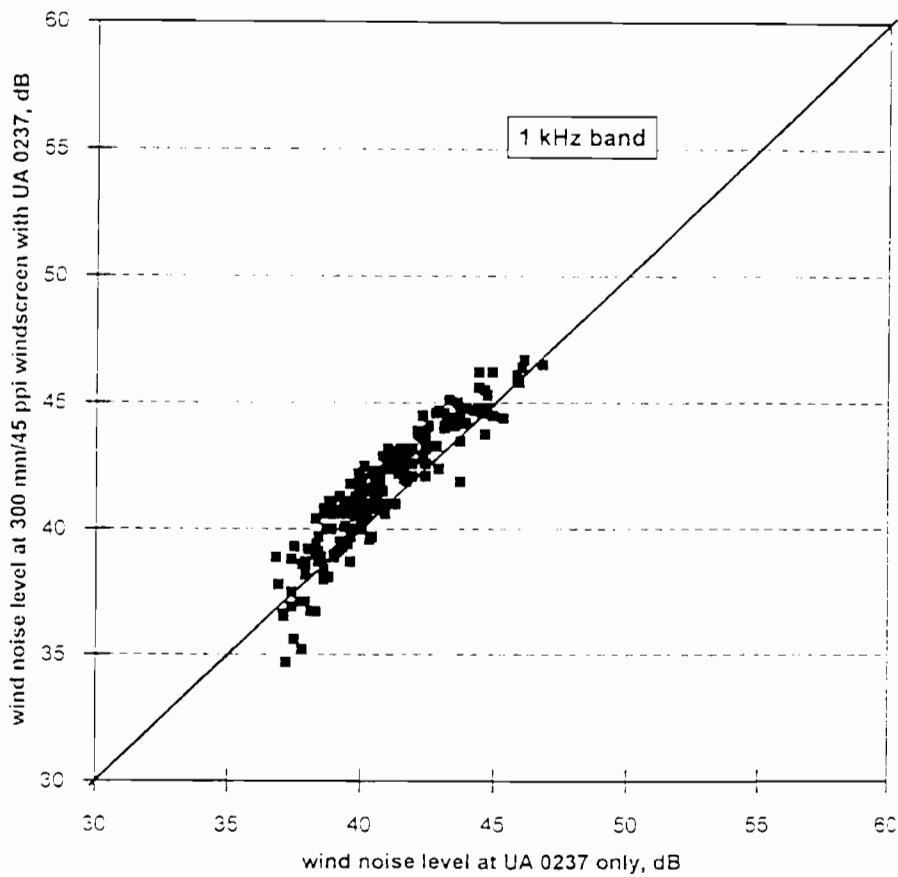
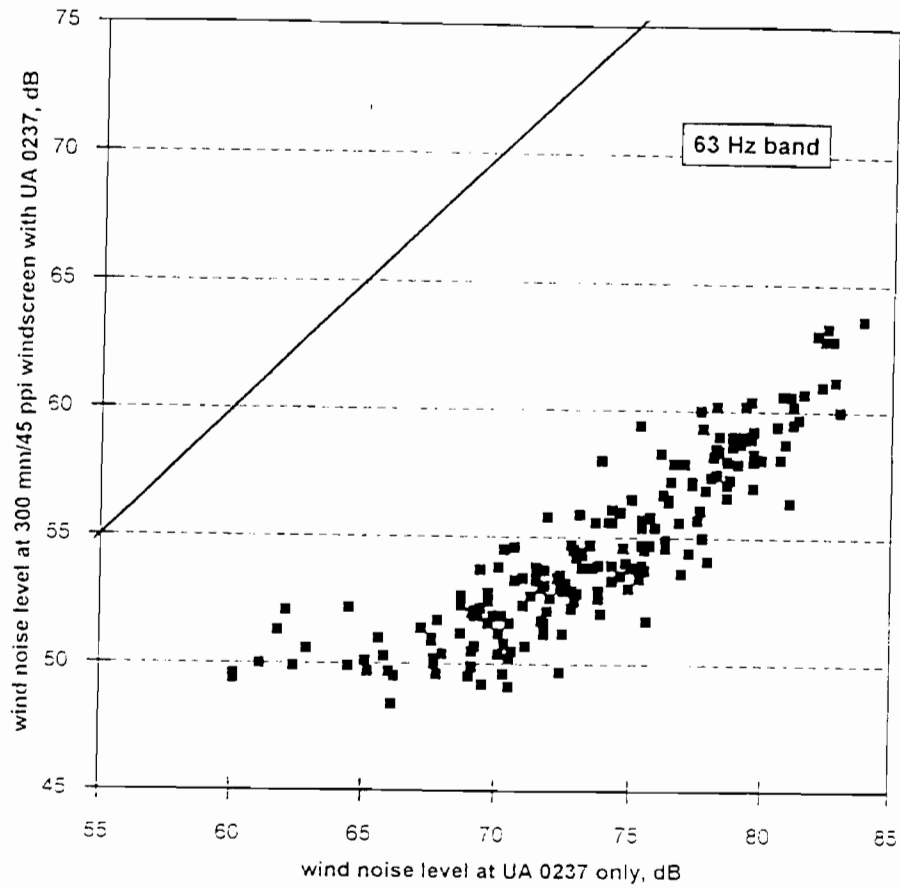

Figure 51 SPL in 63 Hz and 1 kHz bands plotted for 300 mm/45 ppi and UA 0237 windscreens

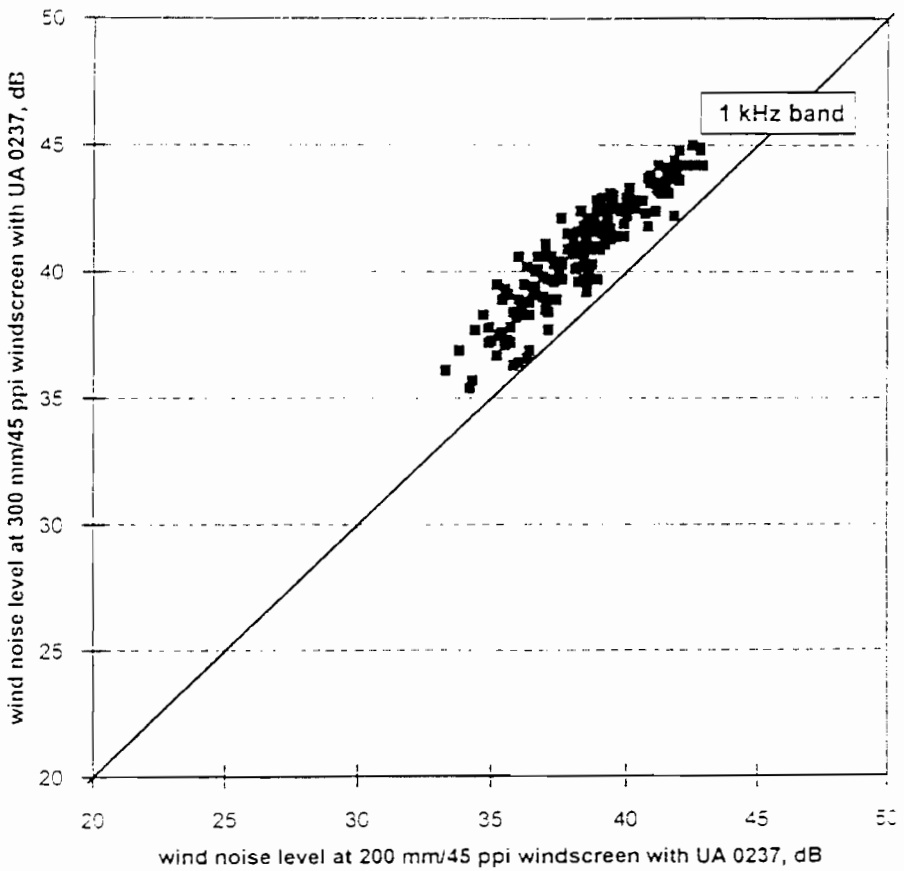
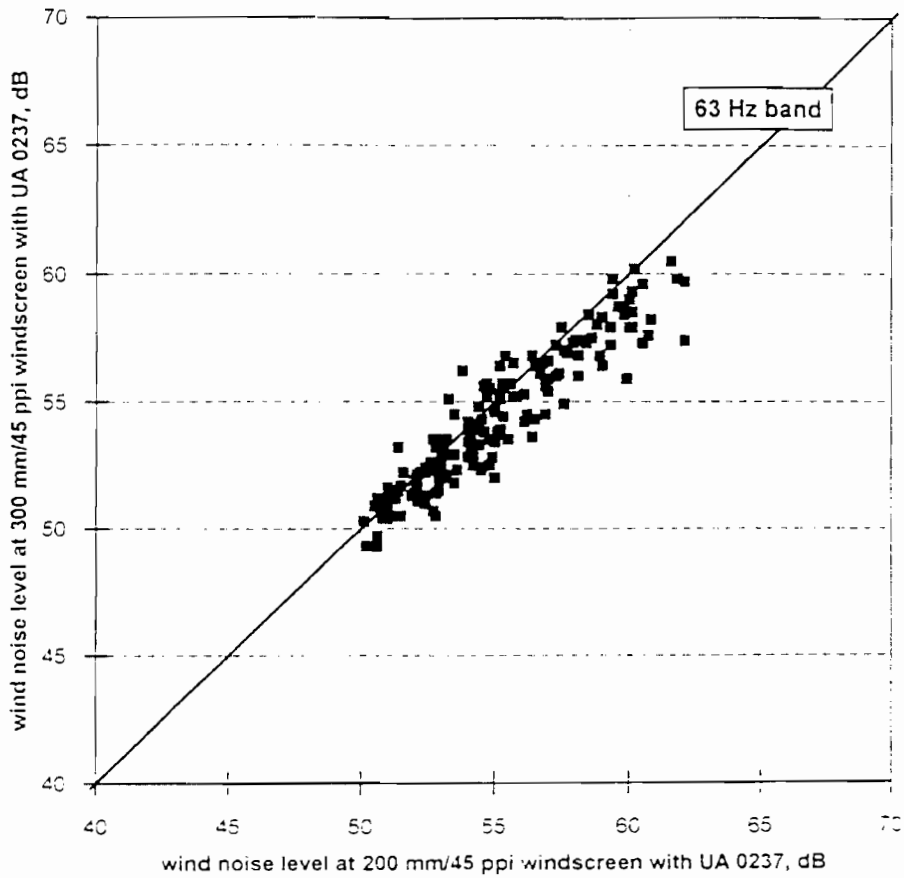

Figure 52 SPL in 63 Hz and 1 kHz bands plotted for 300 mm/45 ppi and 200 mm/45 ppi windscreens

Brüel & Kjær
Type 2133

Plot time:
09-Mar-96
15:35:29

Signed:

Meas. Object:

Comments:

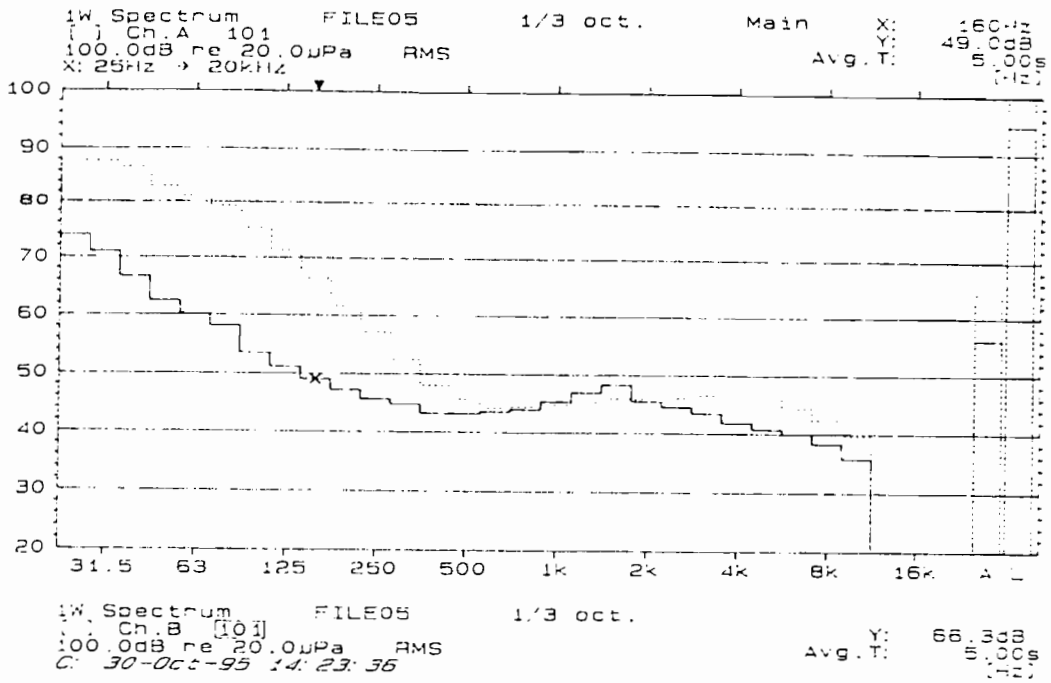

Figure 53 Typical frequency spectra ($L_{eq,5s}$) measured in wind. Upper spectrum - UA 0237 windscreen. Lower spectrum - 300 mm/45 ppi windscreen

Brüel & Kjær
Type 2133

Plot time:
09-Mar-96
15:22:47

Signed:

Meas. Object:

Comments:

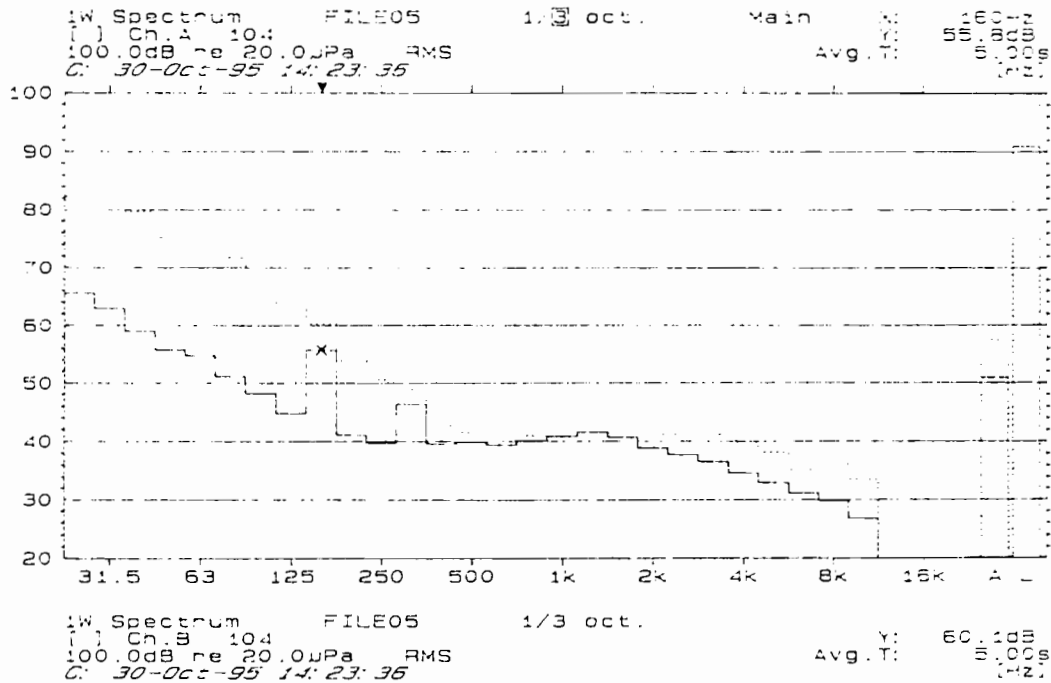

Figure 54 Frequency spectra measured during aircraft flyover, showing aircraft noise 'peak on system with 300 mm/45 ppi windscreen

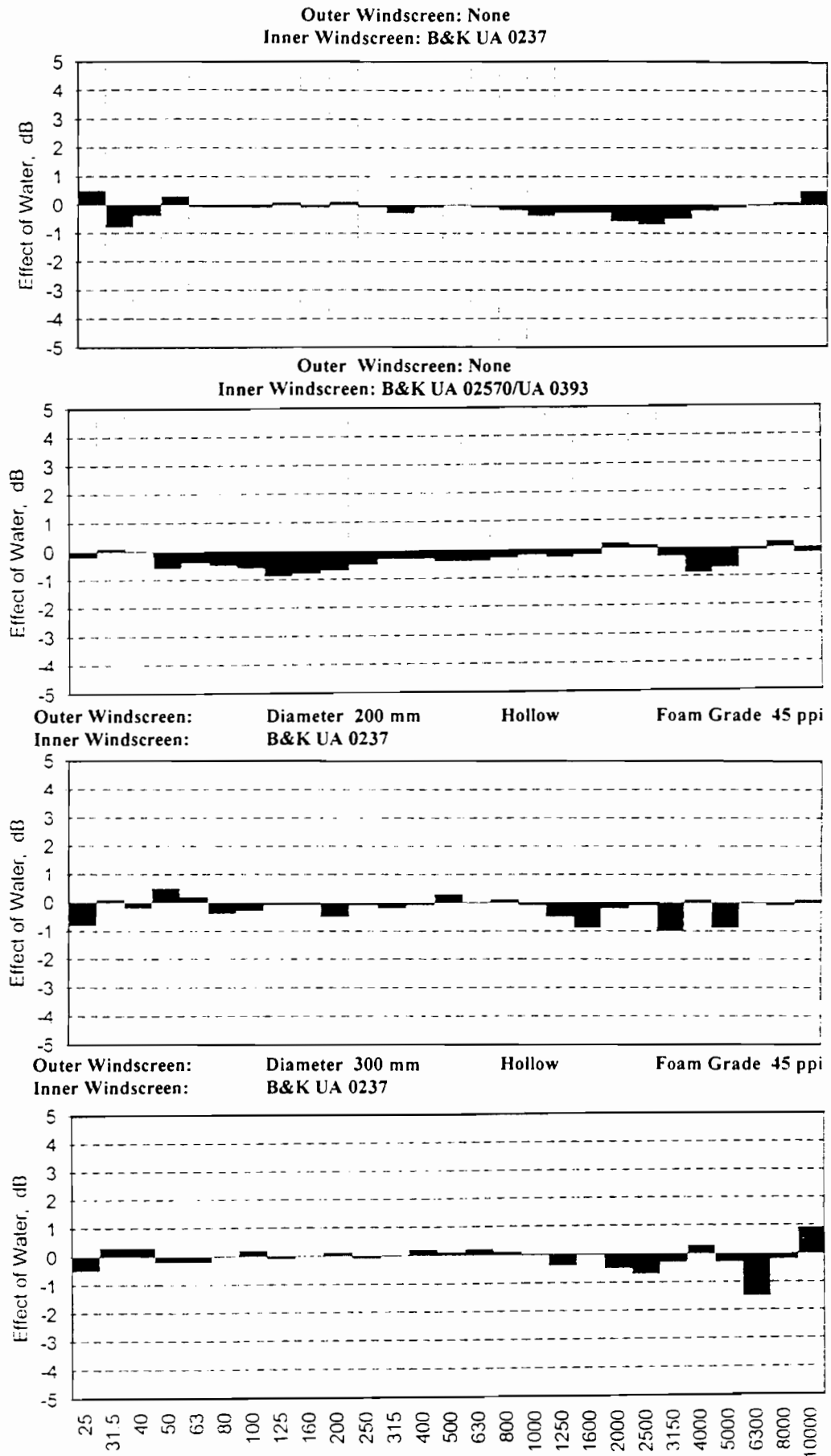

Figure 55 Effect of water absorption on acoustic insertion loss of windscreens

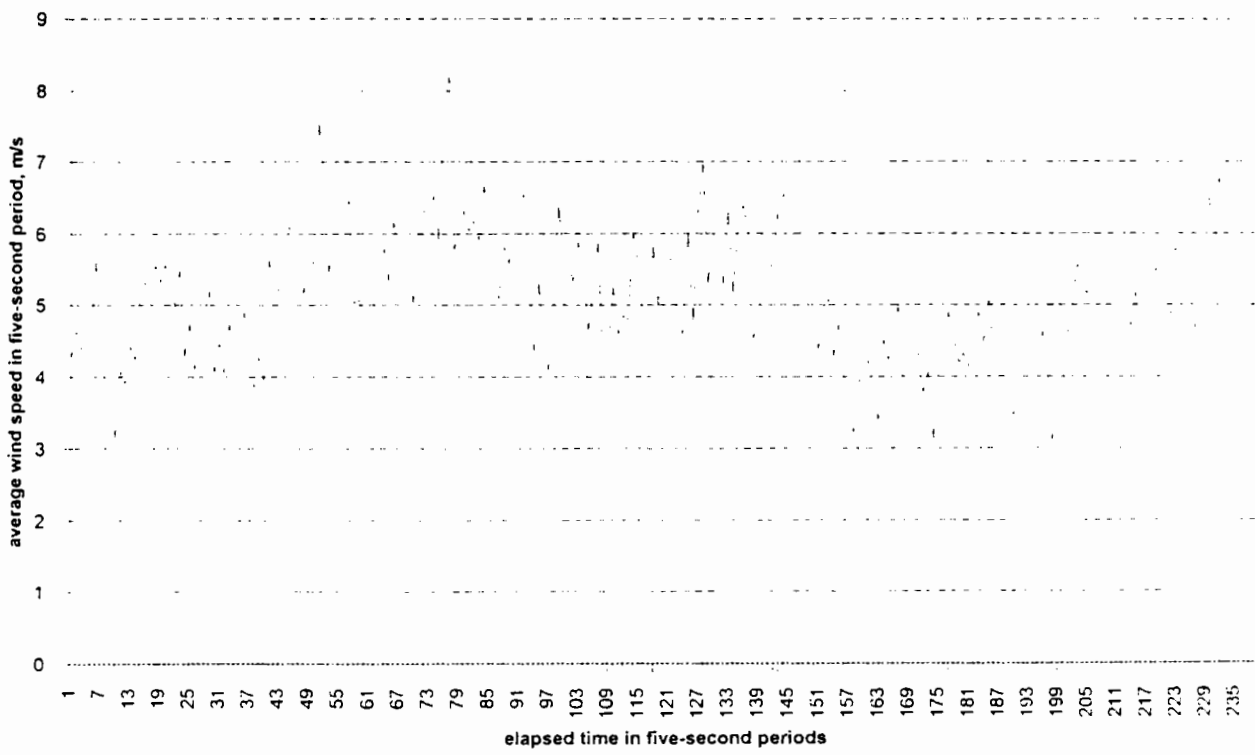

Figure 56 Typical time history of 5-second averaged wind speed over a 20 minute period at Farley Mount

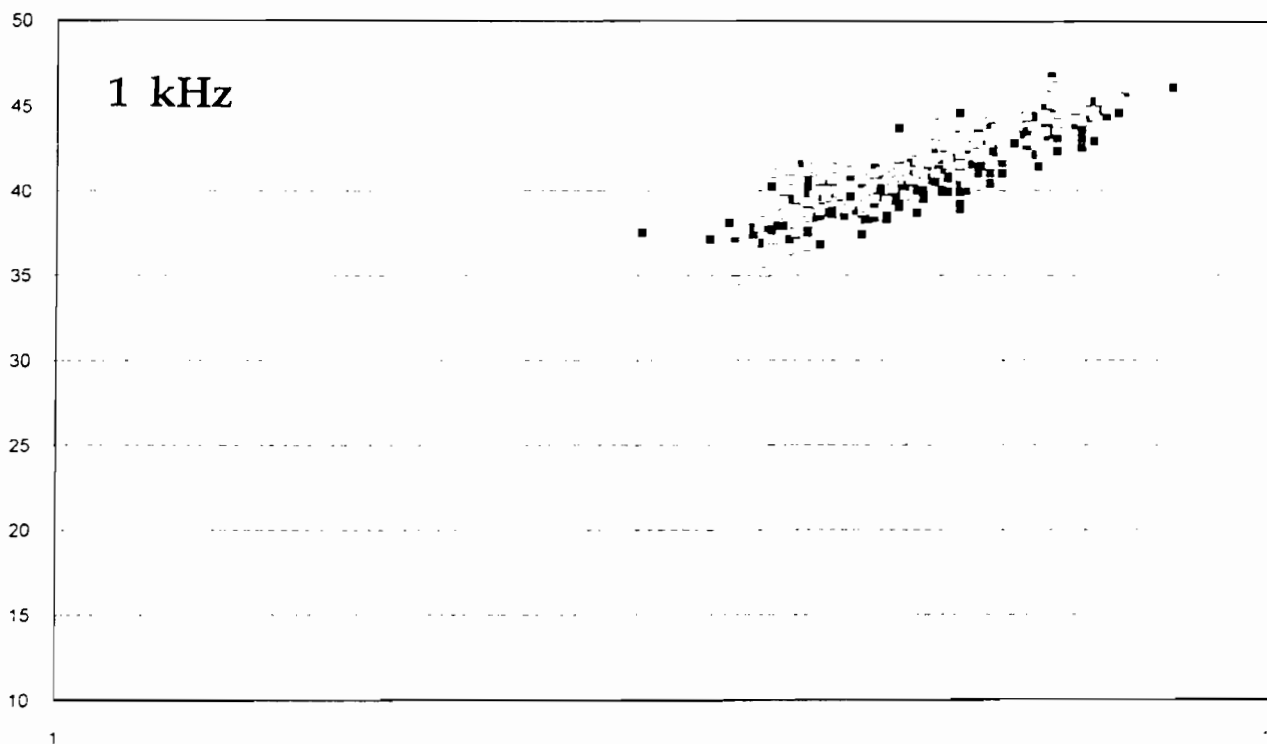
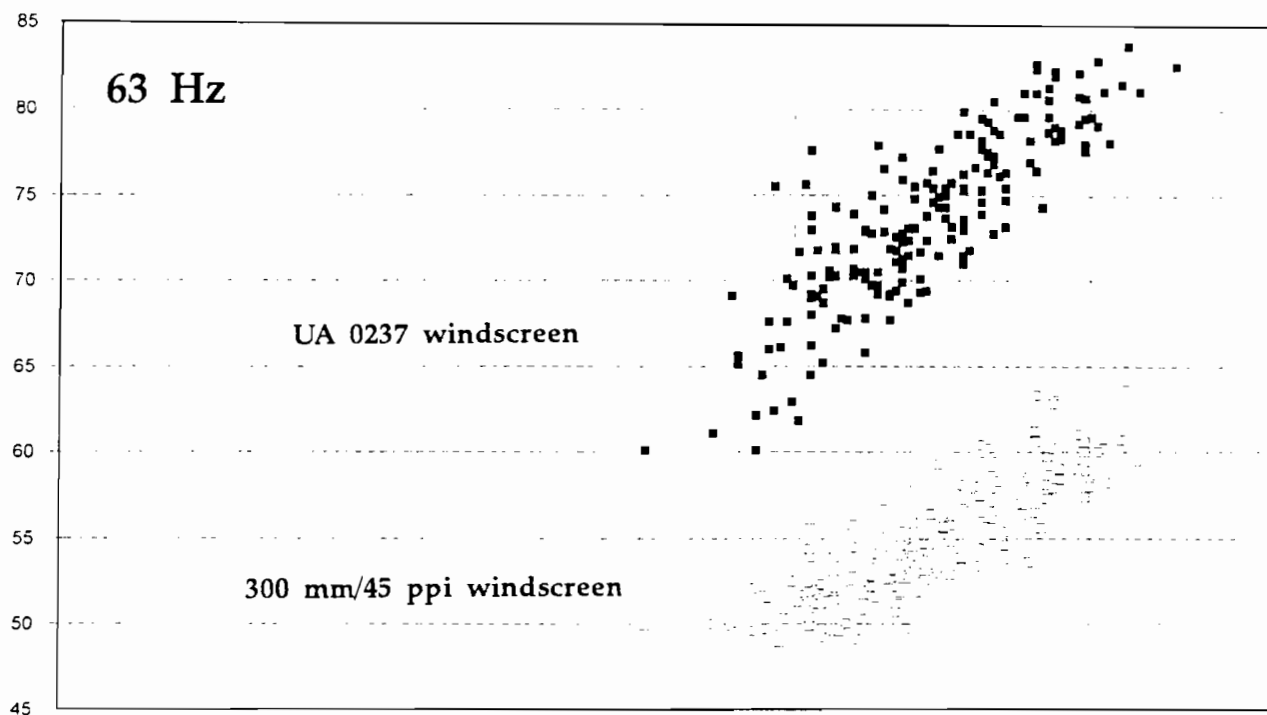

Figure 57 Scatter diagram - 5 second averaged SPL in 63 Hz and 1 kHz bands -v- wind speed m/s

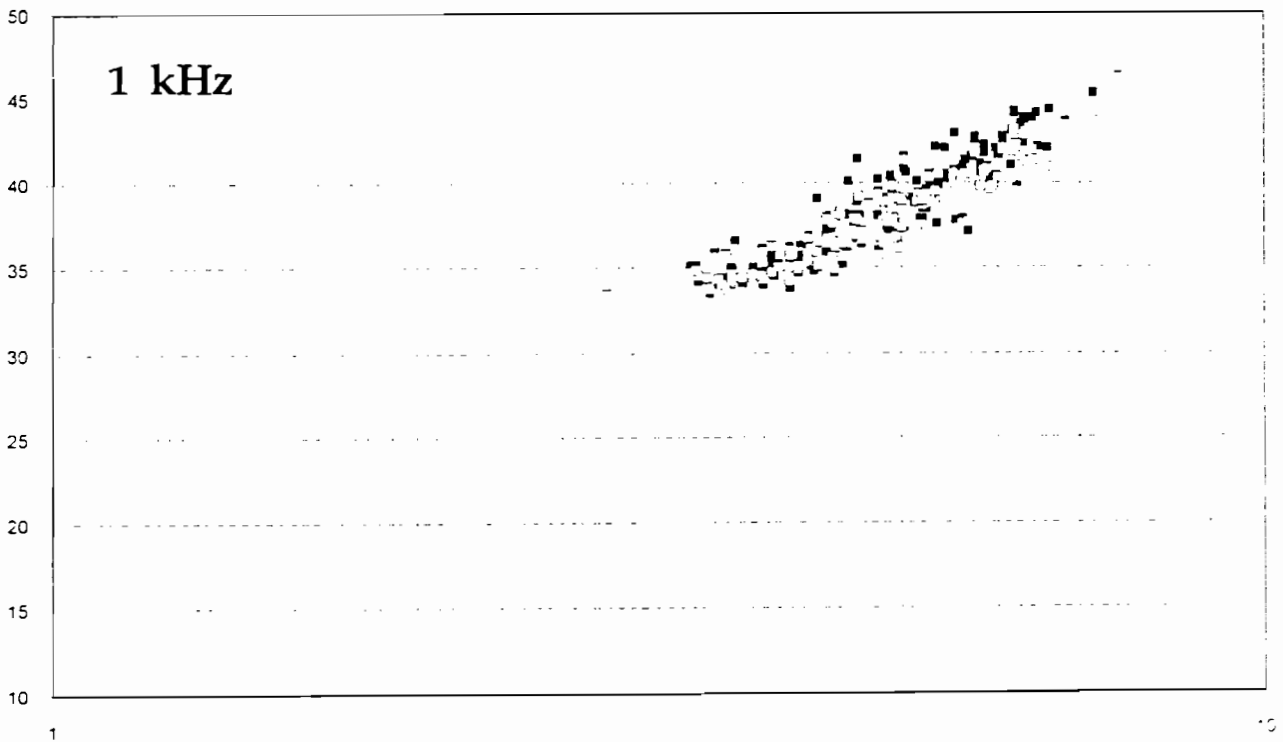
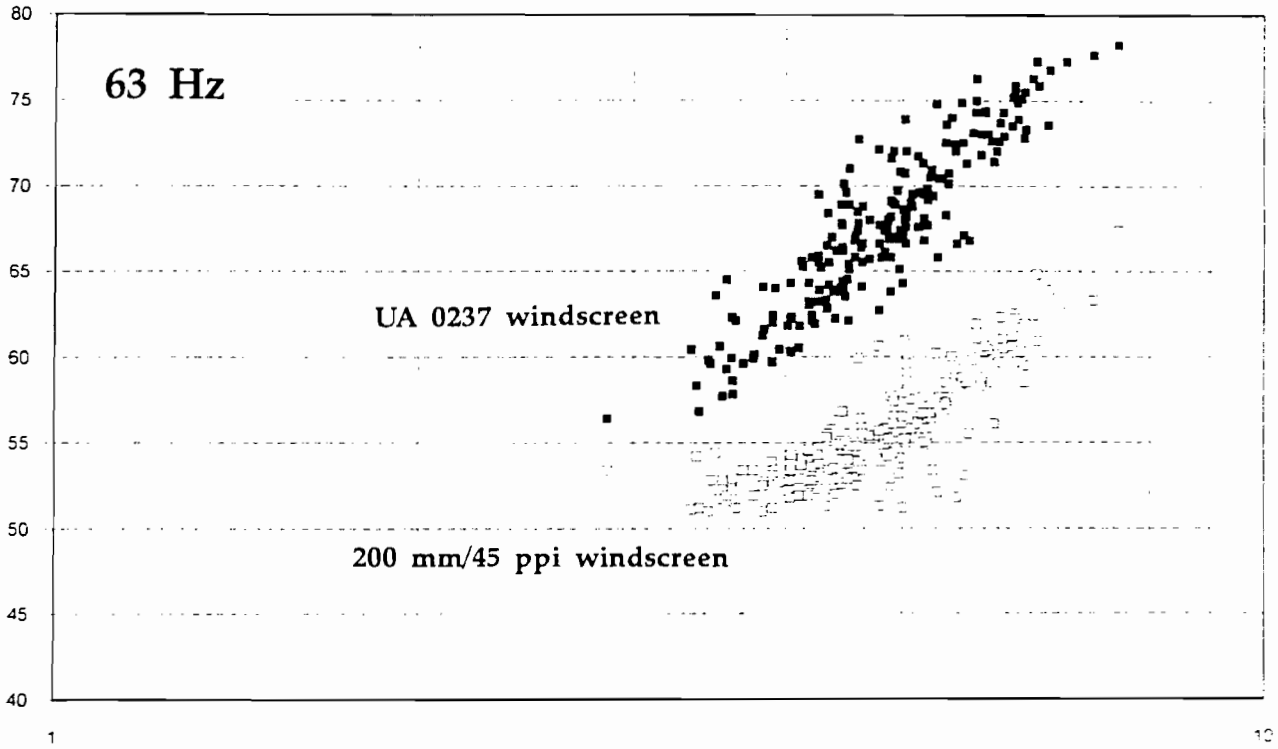

Figure 58 Scatter diagram - 5 second averaged SPL in 63 Hz and 1 kHz bands -v- wind speed m/s

Appendix A

Windscreens and Wind Noise in Microphones : A Literature Review

Contents	Page
Summary	
A.1 Introduction	A.1
A.2 Literature Search Strategy	A.3
A.3 Sources and Characteristics of Wind Noise	A.4
A.3.1 Sources of wind noise	A.4
A.3.2 Characteristics of wind noise	A.5
A.4 Reduction of Wind Noise by Various Methods	A.6
A.5 Theory and Practice in Designing Windscreen	A.8
A.5.1 How windscreens work	A.8
A.5.2 Effects of shape and size	A.9
A.5.3 Materials, porosity and roughness	A.10
A.5.4 Side-effects of windscreens	A.11
A.5.5 Effects of rain	A.11
A.5.6 Practical designs in the literature	A.12
A.6 Methods of Measuring Wind Noise and Windscreen Effectiveness	A.14
A.7 Windscreen Configurations	A.15
A.8 References	A.16

Summary of Appendix A

The assessment of noise from existing or proposed wind farms requires noise measurements to be made in mean wind speeds of up to at least 10 m/s. Existing commercially available microphone windscreens provide inadequate control of wind noise at such high wind speeds.

The objective of this study is to develop and test an improved design of microphone windscreen which will have significantly better performance than the available designs in reducing wind-induced noise, while being relatively simple to construct and suitable for use with standard noise-measurement microphones.

This Appendix presents the conclusions of an initial study, a literature search to identify and review relevant published work, current research, and other sources of information.

A.1 Introduction

Noise is an important consideration in planning and developing wind farms. Although newer designs of wind turbines are quieter than early models, the effect of noise on the local community, typically a relatively small number of isolated dwellings, must be assessed. The criteria for the assessment are a matter for debate, although it is generally agreed that account must be taken of the pre-existing background noise outside nearby dwellings, as well as the noise from the wind farm itself.

The noise from a proposed wind farm must be predicted from measurements made around existing sites. Noise from existing wind farms must be monitored not only to ensure compliance with planning conditions but also to provide up-to-date noise data for improved predictions at future sites. At each dwelling the background noise and the noise from the wind turbines will vary with the wind speed and direction. Measurements of both background noise and wind turbine noise must necessarily be made over a wide and representative range of wind speeds and weather conditions. To obtain sufficient data, noise and meteorological parameters must be recorded simultaneously over long periods, and the duration of the measurement periods generally necessitates the deployment of unattended equipment.

The particular requirement for noise measurements to be made over a range of wind speeds causes significant problems. The most critical is the 'wind noise' generated at a microphone assembly in the moving air. Turbulence inherent in the incoming unsteady air stream, or induced in the air flow by the microphone itself, creates pressure fluctuations at the microphone which are indistinguishable from the sound pressures generated by the noise sources being measured. Manufacturers of measurement systems have developed windscreens, usually in the form of a spherical or cylindrical 'envelope' of open-cell polyurethane foam or nylon mesh stretched over a wire frame. These windscreens are adequate for most environmental noise measurements, but they have been found to be inadequate for measurements close to wind farm sites, where there is often a requirement to be able to measure noise levels below 45 dB(A) in mean wind speeds of 10 m/s or higher.

There is therefore an urgent need for a method of reducing the effects of microphone wind noise on the accuracy of the sound level measurements used to assess noise in

communities near wind farm sites. The method would also have wider applications in monitoring outdoor environmental and industrial noise levels generally.

The Energy Technology Support Unit (ETSU) of the Department of Trade and Industry has commissioned ISVR Consultancy Services to carry out a study on measuring noise in windy conditions, directed towards the development of an improved microphone windscreen. This Appendix presents an assessment, based on a review of the literature, of the principal factors affecting the design and testing of microphone windscreens.

A.2 Literature Search Strategy

In searches of this kind the use of key words such as 'wind', 'flow' or 'noise' are likely to yield too many referenced papers. However, there are relatively few papers published on 'microphone(s)' each year and reference titles can be scanned efficiently even without additional key words. The latter approach was adopted using the Science Citation index as the main source augmented by the indexes of journals known to contain relevant papers, specifically the Journal of the Acoustical Society of America and the Journal of the Audio Engineering Society. The reference lists of the papers discovered from the indexes were then used as additional sources for earlier papers.

A.3 Sources and Characteristics of Wind Noise

A.3.1 Sources of wind noise

Phelps [1], Bleazey [2] and many others identify three sources of wind noise in the output signal of a microphone:

- 1 There may be pressure fluctuations due to velocity fluctuations present in the wind even though the microphone is absent.
- 2 There may be pressure fluctuations due to turbulence produced by the microphone in a wind otherwise free from turbulence, ie in a wind of uniform velocity and flow.
- 3 There may be noise radiated from the first two sources.

Skøde [3] and Keleman [4] also identify as a separate source

- 4 The interaction of existing pressure fluctuations with pressure fluctuations caused by the microphone.

The first source may be reduced by screening, the second by streamlining the microphone casing. The third and fourth sources will then also be reduced.

With natural outdoor winds, Morgan & Raspert [5] have demonstrated that the dominant source of pressure fluctuations is the intrinsic turbulence of the flow, ie source number 1 in the list above, a finding consistent with assertions made in earlier references (eg Wuttke [6]). This is not the case with many laboratory-based indoor measurements with low-turbulence flow. The findings of these laboratory studies may not therefore accord with outdoor measurements. The scales of outdoor turbulence in wind are determined by surface roughness, meteorological parameters, and the depth of the planetary boundary layer [5].

A.3.2 Characteristics of wind noise

Most energy in wind noise is at infrasonic and low audible frequencies (eg Robertson [7], Borwick [8]), reducing as frequency increases giving a characteristic 'heavy rumble' Wuttke [6]. Wind noise is a function of the wind velocity, wind noise increasing with speed.

Wind noise is also dependent on microphone design, size and method of operation, ie whether the microphone is pressure or pressure-gradient operated [6]. **Pressure-operated** microphones, the type where sound has access to one side of the diaphragm only, are essentially omnidirectional. Almost without exception, sound level measurements are made with pressure-operated microphones. (Note that instrumentation microphones, whether designated 'pressure' or 'free-field', are pressure-operated). In a **pressure-gradient** microphone, sound has access via damped ports to the rear of the diaphragm as well as the front. This configuration is used for close-talking noise-cancelling communications microphones or for high-quality directional microphones for broadcasting or recording. Fortunately for those making noise measurements, pressure microphones are inherently less sensitive than pressure-gradient microphones to wind noise [6].

This report is concerned solely with the design and performance of windscreens for pressure-operated microphones.

A.4 Reduction of Wind Noise by Various Methods

For noise measurements in smooth unidirectional air flows, such as within wind tunnels or in ducts, the turbulence caused by the microphone itself, the 'self-noise' (to borrow a term from hydrophone technology), can be reduced by streamlining the microphone. The usual method with instrumentation microphones is to fit a parabolic nose cone (Skøde 1965 [3], Brock 1986 [9]). Phelps [1] describes the 'Bernoulli windscreen' which apparently was also successful under these conditions. Bruel and Kjaer supply nose cones for their range of instrumentation microphones. A nose cone is ineffective in reducing pressure fluctuations resulting from turbulence in the incoming flow.

In uni-directional turbulent flows, a turbulence screen (Friedrich Tube) such as that described by Niese [10, 11, 12] can also be used. A turbulence screen is manufactured by Brüel & Kjær as Part No UA 0436. This is a tube which fits in front of the diaphragm of a half-inch microphone. The end of the tube further from the diaphragm is a parabolic nose cone which is pointed into the air flow. Along the side of the tube is a slit with a fine mesh. Because sound propagates at about the same speed inside and outside the tube, sound entering the tube along the length of the slit arrives in phase at the diaphragm. Turbulent pressure fluctuations in the air flow, however, propagate along the tube at the air speed and the resulting pressure fluctuations within the tube largely cancel along the length. A turbulence tube significantly affects the microphone directionality, which renders it unsuitable for general environmental noise measurements.

The use of multiple microphones and coherence techniques is an effective method of rejecting wind-induced noise from a measured signal. Chung [13] and Alfredson [14] describe the use of such techniques. However, these measurement methods require relatively complex instrumentation, and their application in outdoor noise measurements in wind has not been developed. Such techniques are outside the scope of this study.

A technique used in the broadcasting and recording industry is to combine the use of a windscreen with a high-pass filter having a cut-off frequency between 60 - 200 Hz. Filtering out the low frequencies removes much of the wind noise itself but has little audible effect on speech and many outdoor sounds. Filtering also has an important

effect in preventing low-frequency and infrasonic pressure fluctuations from overloading the electronic circuits following the filter [6, 8], which can cause intrusive harmonic and intermodulation distortion products across a wide frequency range. Such filtering is obviously not a solution to reducing wind noise interference with environmental noise measurements, where instrumentation frequency response is prescribed in the appropriate measurement standards.

It is concluded that the use of a porous windscreen to envelop the microphone offers the most appropriate solution to the problem of carrying out wide-bandwidth sound measurements in windy conditions. Design considerations applicable to windscreens are discussed in Section 5.

The proposed method for the measurement of noise from wind turbines [15] utilises a microphone positioned on a board placed on the ground. This minimises wind-induced noise and the influence of ground reflections. This technique is specifically intended to provide a standardised method for determining the noise emission from a single wind turbine, using measurement positions close to the turbine, and has no application to the measurement of noise for the purposes of environmental assessment.

A.5 Theory and Practice in Designing Windscreen

Bleazey [2] defines a windscreen as 'an enclosure for a microphone which offers negligible attenuation to sound-excited pressure fluctuations and high-attenuation to wind-excited fluctuations'. Wuttke [6] points out that 'the more effective a windscreen is at reducing wind interference, the more the sound pickup will be affected. Ignoring the sound, a closed box would then be the very best windscreen. Thus our goal must be to reach a reasonable compromise.'

Early designs of windscreen were open frames covered with one or more layers of cotton, fine-mesh fabric, metal screens or similar. This type of construction is designated 'basket-style' by Wuttke. More recently open-cell plastic foam windscreens have become very common because they are cheaper and more robust than basket screens.

A.5.1 How windscreens work

Windscreens work by reducing or eliminating steady or unsteady air flow at the microphone. The windscreen itself now acts as a new source of turbulence but the turbulence is at a greater distance from the microphone. Schomer et al [16] also explain that the inherent, incoherent turbulence in the wind is effectively averaged and cancelled over the surface of the windscreen, which is a far larger surface than the front of the microphone. More open materials let more air flow through to the microphone but cause less turbulence about themselves, whereas closer, denser materials form more of an obstruction to the airflow and cause turbulence in their wake. There can therefore be a balance between 'flow-through' and 'wake' wind noise. The flow-through noise is at higher frequencies than the wake noise. The porosity of a foam screen or the weave of a cloth screen is therefore important.

Partial theoretical treatments have been presented over the years by Phelps [1], Bleazey [2] and more recently Strasberg [17]. Strasberg observes that the wind noise sensed by a microphone inside a windscreen is 'a complicated aerodynamic noise phenomenon that has resisted theoretical analysis'. He identifies the variables determining wind noise in a given frequency band as the frequency and bandwidth, the size and shape of the windscreen and its porosity, the details of its construction, the wind speed, the density, viscosity and compressibility of the fluid medium.

Strasberg introduces the properties of the fluid explicitly because he is concerned with hydrophones as well as microphones.

Strasberg applied dimensional analysis to laboratory-based measurements from the published literature on cylindrical and spherical windscreens. He showed that the data may be represented by a single universal curve if plotted in nondimensional form. Appropriate graphs are obtained by plotting a dimensionless sound pressure coefficient, $\bar{p}_{1/3} / \rho V^2$, or a dimensionless spectral density, $fS/\rho^2 V^4$, against a dimensionless frequency, fD/V , ie the Strouhal Number, where f is frequency, D is screen diameter, V is wind speed, $\bar{p}_{1/3}$ is the sound pressure of the wind noise in a one-third octave band, ρ is fluid density and S is the spectral density of the wind noise at frequency f .

Strasberg gives the equation

$$L_{1/3} = 61 + 63 \text{ Log } \underline{V} - 23 \text{ Log } f - 23 \text{ Log } \underline{D}$$

where $L_{1/3}$ is the one-third octave band sound level in decibels, f is frequency in Hz, \underline{V} is wind speed in m/s and \underline{D} is the screen diameter in centimetres. This implies that wind noise increases at 19 dB per doubling of wind speed, but decreases at 7 dB per octave as frequency increases, and decreases at 7 dB per doubling of the windscreen diameter. Strasberg admits to omitting various factors such as the distance from the microphone diaphragm to the windscreen surface or the porosity of the screen materials, but nevertheless there was little scatter in the plots. Of more importance is the acknowledgement that the data included in his analysis were limited to laboratory data where turbulence was caused by the introduction of the microphone into a non-turbulent flow, and thus the analysis will not apply for natural winds outdoors where the wind is already turbulent.

A.5.2 Effects of shape and size

The obvious shape for a windscreen, to combine the requirements for minimum wake generation and the ability to accept wind from any direction, is a sphere; however, cylindrical windscreens have been found to be almost equally effective.

Strasberg's analysis above shows roughly a 7 dB reduction in wind noise for a doubling in windscreen diameter. Bleazey's empirical measurements outdoors also show that wind noise is reduced by about 7 dB per doubling of radius except for small screens where the radius is only slightly larger than the microphone's and where the reduction in wind noise has a greater rate of increase with radius. Bleazey also found that the reduction of wind noise increased with the volume of the windscreen. Plotting wind noise attenuation against the logarithm of the enclosed volume of the screen not occupied by the microphone was highly linear, with a slope of about 2 dB per doubling of volume.

A.5.3 Materials, porosity and roughness

Bleazey measured the wind noise attenuation for fine-mesh silk, 60 mesh per inch cotton and 'monk's cloth' windscreens. Only a slight increase in attenuation was noted when extra layers of silk were added to the original single layer. He concluded that the turbulence produced at the surface of the single layer was almost as great as that produced by multiple layers and that the noise produced by turbulence at the screen was greater than the wind leakage through the silk. The other materials were equally effective in attenuating wind noise, but the single layer of silk was the least detrimental to the frequency response of the microphone at high frequencies.

The effect of porosity has been studied empirically for foam windscreens. Wuttke states that open cell foam with between 50 and 80 pores per linear inch (approximately 2000 - 3000 pores per meter or ppm) is ideal [6]. Brüel & Kjær do not state the porosity of their windscreens but an inspection of some samples under a magnifying glass suggests that they are probably about 1200 - 2500 ppm, noticeably varying from sample to sample.

Schomer et al [16] cite data from Hosier and Donovan for low-porosity 500 ppm and high porosity 1200 ppm foam, the latter being the more effective. Note that authors tend to use the term high-porosity for materials with small holes (high values of ppm) and low-porosity for material with large holes (low values of ppm), which is not necessarily intuitive. Schomer et al's own designs use an outer cylinder of 400ppm foam enclosing an inner foam ball of 1200 ppm. The low porosity outer foam is intended to allow some through air flow to minimise 'wake' noise, while reducing the

air speed over the inner foam ball which then reduces the 'flow-through' noise, wake noise from the inner ball not being a problem at the reduced air speed.

Morgan and Raspet [5] state that the surface roughness of foam windscreen will reduce the width of the turbulent wake by moving the separation point of the flow from the windscreen further aft.

A.5.4 Side-effects of windscreens

Basket type screens often cause small but wide peaks as well as dips in a microphone frequency response. These are due to internal reflections within the screen and diffraction around the screen [6] rather than sound transmission through the screen. Thin layers of cloth or foam over a frame can flutter if care is not taken, and exposed parts of a frame can cause turbulence and whistling or rustling noises [6]. Some fabrics will stretch or tighten with the relative humidity [18]. Loose fabrics lose their effectiveness [18]. Very tightly stretched fabric can become 'tuned' to give a characteristic noise as the wind passes over [18, 19].

'Solid' foam windscreens do not suffer these effects but instead tend to cause a smooth, gradual high frequency roll-off. [6]

Note that all windscreens which are effective in reducing wind noise will have some effect upon the microphone frequency response. Although the effect may be very slight and can be disregarded for most purposes, a microphone and measurement system, when fitted with a windscreen of any type, may no longer satisfy the strict requirements for IEC Type 1 classification (formerly known as precision grade).

A.5.5 Effects of rain

Nelson and Godfrey [20] have demonstrated that for a foam windscreen (Brüel & Kjær UA 0082) 'the standard practice of neglecting the acoustic sensitivity of the windscreen whether wet or dry will not appreciably affect the accuracy of outdoor measurements of traffic noise.' They were concerned with the effect of the windscreen on the frequency response and calibrated sensitivity of the microphone as it affected overall A-weighted levels. No tests were made to compare the effectiveness in reducing wind noise of a wet windscreen with a dry windscreen.

Brüel & Kjør state that the sound attenuation for their general purpose foam windscreen (Type UA 0237) when wet is within +3 dB/-2 dB of the attenuation when dry between 1.5 kHz and 20 kHz [21].

The sound attenuation of their 'permanent outdoor' windscreen Type UA 0570 when wet is within ± 0.5 dB of the attenuation of the dry screen for frequencies up to 9 kHz [21].

A.5.6 Practical designs in the literature

A problem with much of the literature is that the reduction in wind noise given by a given windscreen design is measured or expressed fairly vaguely or differently by different authors. A further problem is that measured data may be specific to a particular microphone type, because the noise at the unscreened microphone is often taken as a reference datum.

Nevertheless certain findings emerge. The tenor of Wuttke's article [6] is that foam windscreens are by far the most effective single layer solution for pressure operated microphones. Cook [22] however demonstrated that a windscreen made of 'shadedcloth' with dimensions of 800 mm x 800 mm x 1400 mm high was more effective than a commercial foam windscreen, but the dimensions are a drawback, and whether the design could survive high wind speeds is not known.

There are other designs in the literature which by implication perform better than the foam ball. These other designs however are more complex with multiple layers, usually a basket outer screen around a foam ball inner screen with an air gap between. Sometimes multiple layers are used.

Most robust is Hilliard's design [23], which has a stainless steel mesh lined with 20 pore per inch foam as an outer basket and an inner cloth or metallic screen nearer the microphone. This is claimed to give 20-25 dB reduction in wind noise with less than 2 dB acoustic noise reduction at 8 kHz. It was designed for airport noise monitoring.

Schomer et al [16] used a 40 cm diameter x 90 cm high vertical cylinder outer skin of 25 mm thick, 400 ppm foam surrounding a half-inch microphone fitted with a 17 cm

diameter, 1200 ppm foam ball. On average this system gave a reduction in wind noise of 29 dB(C) compared to 24 dB(C) for the 17 cm foam ball alone, but this improvement was not always apparent in the individual measurements.

IEC/TC88 [15] describes a possible configuration for a secondary windscreen, to be used in addition to a foam hemisphere (for covering a microphone mounted on a board on the ground plane) where additional wind noise reduction is required. The suggested design is in the form of a hemispherical frame of 450 mm diameter, covered with open-cell foam of 4-8 pores per 10mm (ie 400-800 ppm). The basis for this recommendation is not known, although it is consistent with Schomer et al's proposal.

A.6 Methods of Measuring Wind Noise and Windscreen Effectiveness

Various methods have been used to measure wind-induced noise and the effectiveness of windscreens, as detailed in the relevant papers. A useful summary is provided in BS 6840:Part 4:1987 'Sound system equipment. Part 4. Methods for specifying and measuring the characteristics of microphones' [24]. This is the same as IEC 268:1972 'Sound system equipment. Part 4: Microphones' [25].

The standards state:

'All measurements of wind noise are subject to large variation if the stream of air is turbulent at the source or develops turbulence between the source and the microphone. No general method of measurement can be given for equivalent sound pressure due to wind.'

Simple methods of wind production, however are in general use for comparing microphones. Such methods are e.g.:

- the pendulum method;*
- the rotating device method;*
- the riding vehicle method;*
- the wind-tunnel method.'*

None of the above methods attempts to simulate the characteristics of atmospheric turbulence. Some workers have attempted to overcome this deficiency by the following means:

- placing an obstruction in the smooth flow in front of a microphone [6, 9],
- using a custom made radial ventilator [6],
- using various propeller or rotating paddles [1, 2],
- making measurements outdoors in real winds [2, 5, 16, 18, 22].

A.7 Windscreen Configurations

It is a fundamental requirement of this study that any improved windscreen design should be of simple and robust design, capable of being manufactured cheaply by a commercial firm, or of being made up from scratch or a kit of parts by the user, with repeatable results.

From the literature review, two basic windscreen configurations are worthy of investigation:

Single layer screens, in the form of a foam or 'basket' design. The principal variables are diameter and envelope porosity.

Multi-layer screens. From the literature, it is unlikely that any benefit is gained from the use of more than two layers. A practical approach to a two-layer screen is to use the reference B&K UA 0237/0570 as the primary screen, with an additional secondary screen with a foam or wire mesh envelope. The requirement is then to optimise the dimensions and porosity of this secondary screen, which can probably be of cylindrical shape.

A.8 References in Appendix A

- 1 W D Phelps, 1938; *Microphone wind screening*. RCA Review 3, 203 - 212. Radio Corporation of America.
- 2 J C Bleazey, 1961; *Experimental determination of the effectiveness of microphone wind screens*. Journal of the Audio Engineering Society, 9(1), 48 - 54
- 3 F Skøde, 1966; *Windscreening of outdoor microphones*. Brüel & Kjær Technical Review, 3 - 9, 1966 No 1.
- 4 A Kelemen, 1971; *Wind noise protection of microphones*. Paper 19E4 Proceedings of the Seventh international Congress of Acoustics, 1, 281-284, Budapest, Hungary.
- 5 S Morgan & R Raspet, 1992; *Investigation of the mechanisms of low-frequency wind noise generation outdoors*. Journal of the Acoustical Society of America, 92(2), 1180 - 1183.
- 6 J Wuttke, 1992; *Microphones and wind*. Journal of the Audio Engineering Society, 40(10), 809 - 817.
- 7 A E Robertson, 1963; *Microphones*. BBC Training Manual, 2nd Edn., 274 - 280, Iliffe Books Ltd, London.
- 8 J Borwick, 1990; pp147 - 148 in *Microphones. Technology and technique* Focal Press, London and Boston ISBN 0-240-51279-0.
- 9 M Brock, 1986; *Wind and turbulence noise of turbulence screen, nose cone, and sound intensity probe with windscreen*. Brüel & Kjær Technical Review, 32 - 39, 1986 No 4.
- 10 W Neise, 1975; *Theoretical and experimental investigations of microphone probes for sound measurements in turbulent flow*. Journal of Sound and Vibration, 39(3), 371 - 400.
- 11 W Neise & B Stahl, 1979; *The flow noise level at microphones in flow ducts*. Journal of Sound and Vibration, 63(4), 561 - 579.
- 12 W Neise, 1991; *Experimental determination of the acoustic sensitivity of a microphone turbulence screen under mean flow conditions*. Internoise 91, 1013 - 1016.
- 13 J Y Chung, 1977; *Rejection of flow noise using a coherence function method*. Journal of the Acoustical Society of America, 62(2), 388 - 395.
- 14 R J Alfredson & M Loh, 1991; *The multiple coherence method for reducing flow noise on microphones*. Internoise 91, 1117 - 1120.
- 15 Committee Draft IEC/TC88 Document; *Acoustic noise measurement techniques for wind turbine generator systems*. June 1994. International Electrotechnical Commission.

- 16 P D Schomer, R Raspet, J Brunner, D Marshall, M Wagner & D Walker, 1990; *Reduction of wind noise for unattended blast noise monitoring*. Noise Control Engineering Journal, **34(2)**, 77 - 88.
- 17 M Strasberg, 1988; *Dimensional analysis of windscreen noise* Journal of the Acoustical Society of America, **83(2)**, 544 - 548.
- 18 L R Burroughs, 1961; *The reduction of wind noise in microphones*. Journal of the Audio Engineering Society, **9**, 168.
- 19 L Burroughs, 1974; *Microphones: design and application*. Pp. 193 - 194, Sagamore Publishing Co, inc., Plainview, New York. ISBN 0-914130-00-5.
- 20 P M Nelson & N S Godfrey, 1978; *A note on the acoustic sensitivity of microphone windscreens*. Applied Acoustics, **11**, 21 - 26.
- 21 Brüel & Kjær, 1982; *Data Handbook. Condenser microphones and microphone preamplifiers for acoustic measurements*
- 22 R Cook, 1991; *Microphone windscreens for low level environmental measurements*. Internoise 91, 969 - 972.
- 23 J K Hilliard, 1971; *Microphone windscreens*. Journal of the Audio Engineering Society, **19(5)**, 426 - 427.
- 24 BS 6840:Part 4: 1987; *Sound system equipment Part 4 Methods for specifying and measuring the characteristics of microphones*. British Standards Institution.
- 25 IEC 268-4;1972; *Sound system equipment Part 4 Microphones*. International Electrotechnical Commission.

Other papers not cited in the text:

P V Bruel, 1960; *Aerodynamically induced noise of microphones and windscreens*. Brüel & Kjær Technical Review, 3 - 26, 1960 No 2.

L L Beranek, 1949; *Microphones in winds*. pp 258 - 264 in *Acoustic Measurements*. John Wiley and Sons, 1949.

R W Leonard, 1954; *The measurement of acoustic pressures in moving air streams*. Acustica, **4**, 110 - 112.

Appendix B

Information on Standard Microphone Windscreens (Brüel and Kjær)

9.2. WINDSCREENS

9.2.1. Permanent Outdoor Windscreen UA 0570

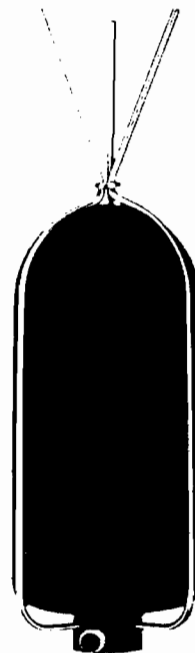

Fig.9.1. Windscreen UA 0570

The Windscreen UA 0570, shown in Fig.9.1., is designed for use in unattended outdoor monitoring applications using a half-inch microphone. The Windscreen is made from a specially prepared porous polyurethane foam which is resistant to humid and corrosive atmospheres and is supported by three stainless steel rods which protrude as spikes preventing interference from birds. The design of the foam screen and stainless steel frame provides excellent long term mechanical stability.

The recommended system for use with the Windscreen consists of a half-inch condenser microphone, Rain Cover UA 0393, Dehumidifier UA 0308 and microphone preamplifier which are inserted into the hard plastic (P.O.M.) conical ring at the base of the Windscreen and secured with a nylon screw, as shown in Fig.9.2.

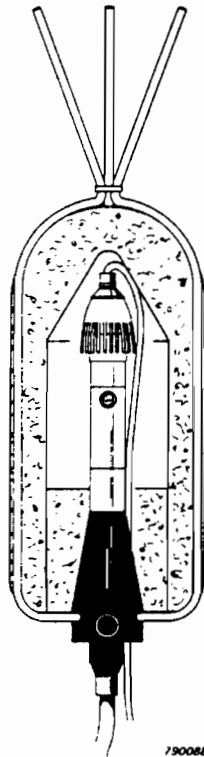

Fig.9.2. Half-inch microphone and preamplifier fitted with Rain Cover UA 0393 and Dehumidifier UA 0308 mounted inside Windscreen UA 0570

The Windscreen gives an effective reduction of wind noise of the order of 15 dB for wind speeds up to 120 km/h. The attenuation of a wet screen differs from that of a dry screen by only $\pm 0,5$ dB up to 9 kHz as shown in Fig.9.3. Wind induced noise levels for half-inch Condenser Microphones Types 4133 and 4149 fitted with Rain Cover UA 0393 and Windscreen UA 0570 are shown in Figs.9.4 to 9.6. Free-field correction curves are given in Fig.9.7 for half-inch Condenser Microphones Types 4133 and 4149, fitted with Rain Cover UA 0393 and Windscreen UA 0570.

Windscreen UA 0570 is also delivered as part of the Outdoor Microphone Unit Type 4921 which is designed for permanent outdoor noise monitoring systems. The unit consists of the quartz coated half-inch Condenser Microphone Type 4149, Rain Cover UA 0393, Windscreen UA 0570, and a Preamplifier mounted on a weather proof case housing an amplifier, calibration oscillator, dehumidifier and a battery pack. For further details, see the 4921 Instruction Manual.

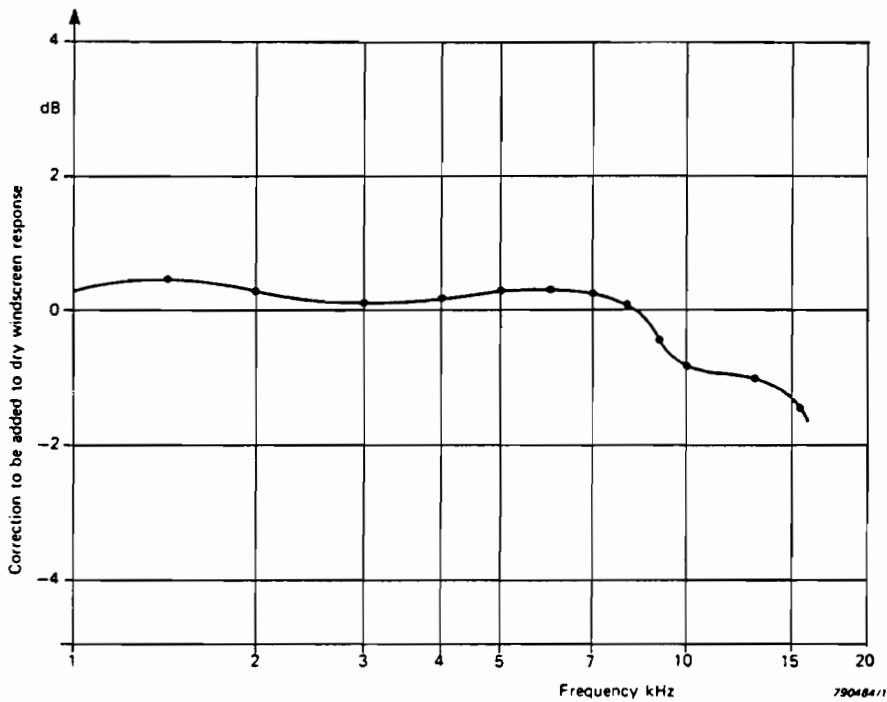

Fig.9.3. Effect of wet screen on the attenuation of Windscreen UA 0570

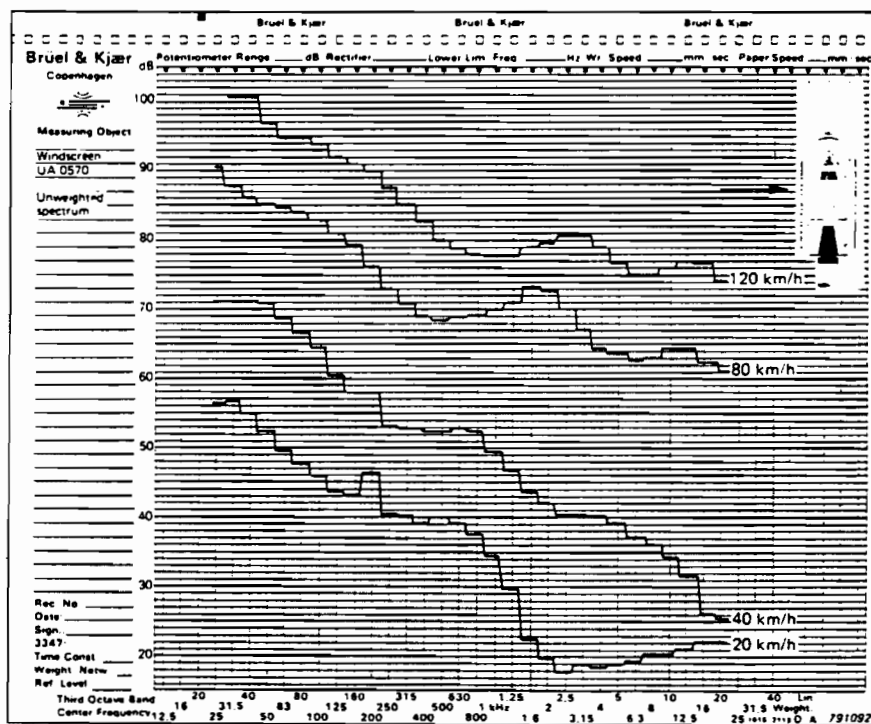

Fig. 9.4. 90° incidence wind induced noise levels for half-inch microphone Type 4133/49 fitted with Rain Cover UA 0393 and Dehumidifier UA 0308 mounted inside Windscreen UA 0570

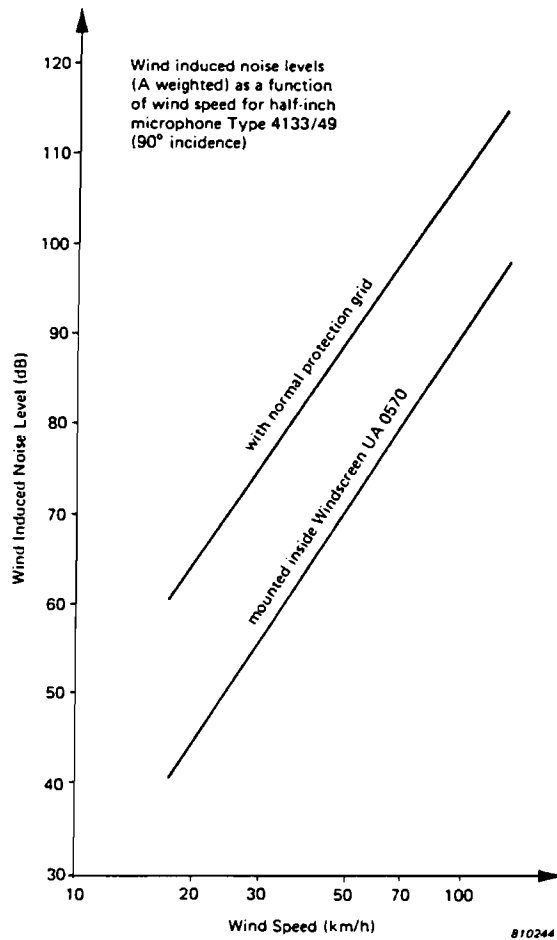

Fig. 9.5. A-weighted wind induced noise level as a function of wind speed for half-inch microphone Type 4133/49 fitted with Rain Cover UA 0393 and Dehumidifier UA 0308 mounted inside Windscreen UA 0570

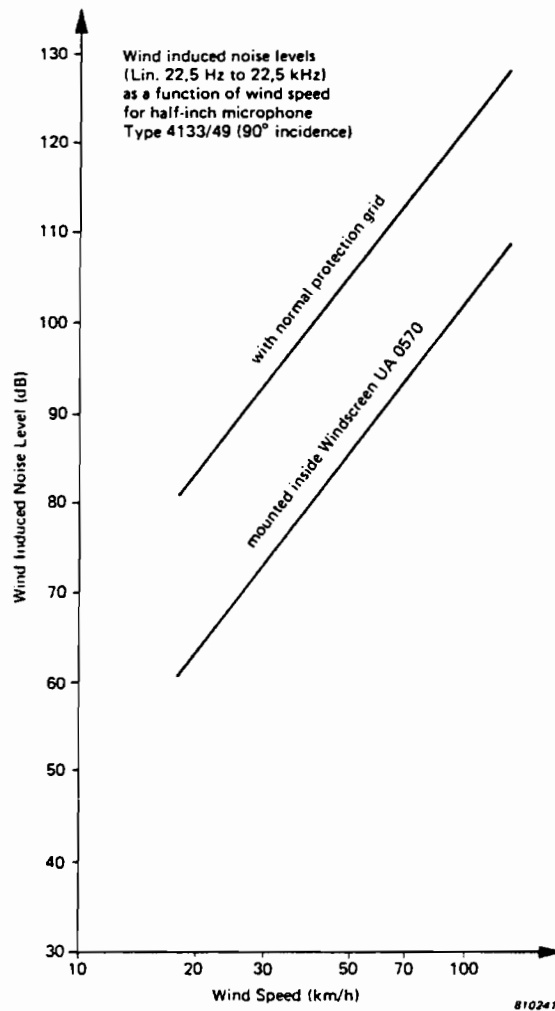

Fig. 9.6. Linear wind induced noise level as a function of wind speed for half-inch microphone Type 4133/49 fitted with Rain Cover UA 0393 and Dehumidifier UA 0308 mounted inside Windscreen UA 0570

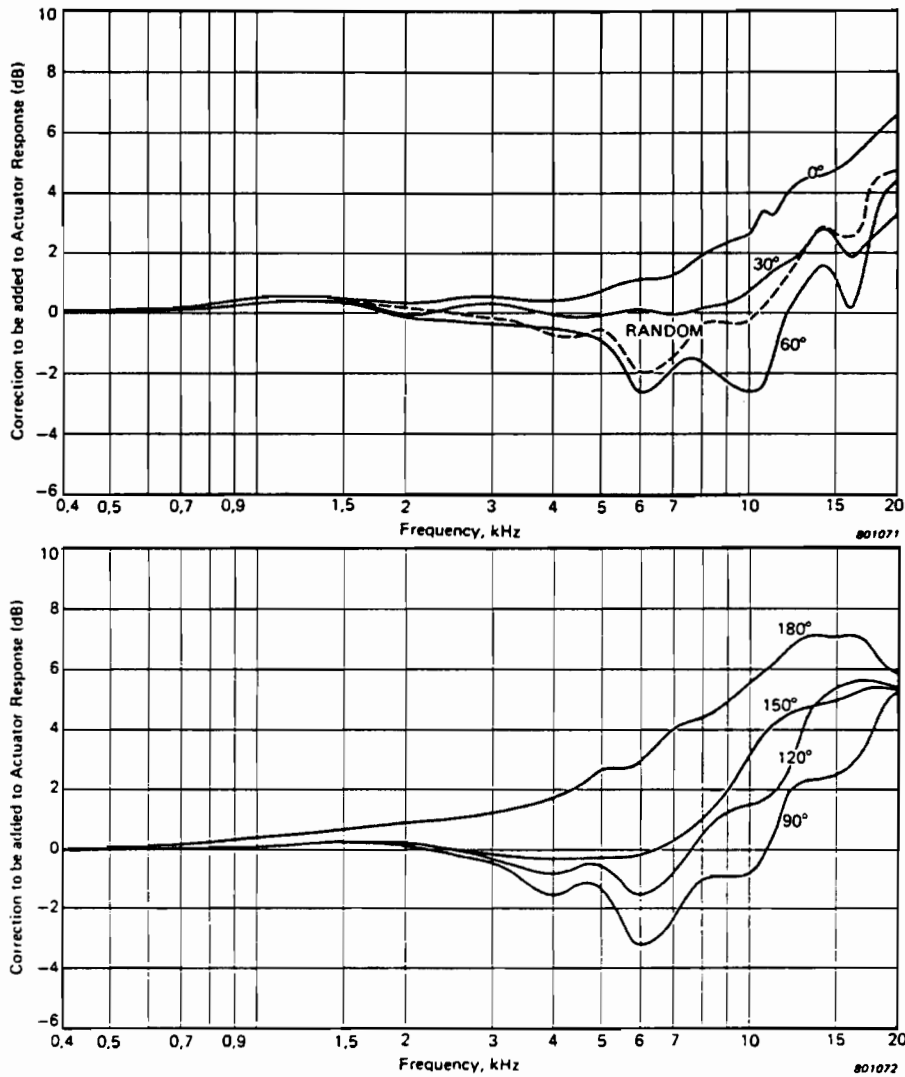

Fig. 9.7. Free-field correction curves for half-inch microphone Type 4133/49 fitted with Rain Cover UA 0393 and Dehumidifier UA 0308 mounted inside Windscreen UA 0570

9.2.2. Foam Windscreens

The Windscreens UA 0207 and UA 0237 are available for use with one-inch and half-inch microphones respectively. The Windscreens are identical in size and material, and differ only in the diameter of the cylindrical hole provided for insertion of the microphone and preamplifier.

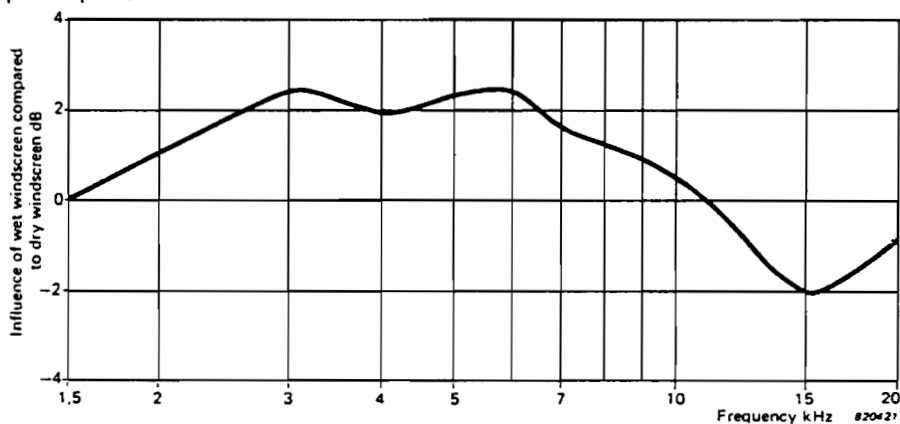

Fig.9.8. Effect of UA 0237 wet screen 0° incidence free-field response of half-inch microphone Type 4133

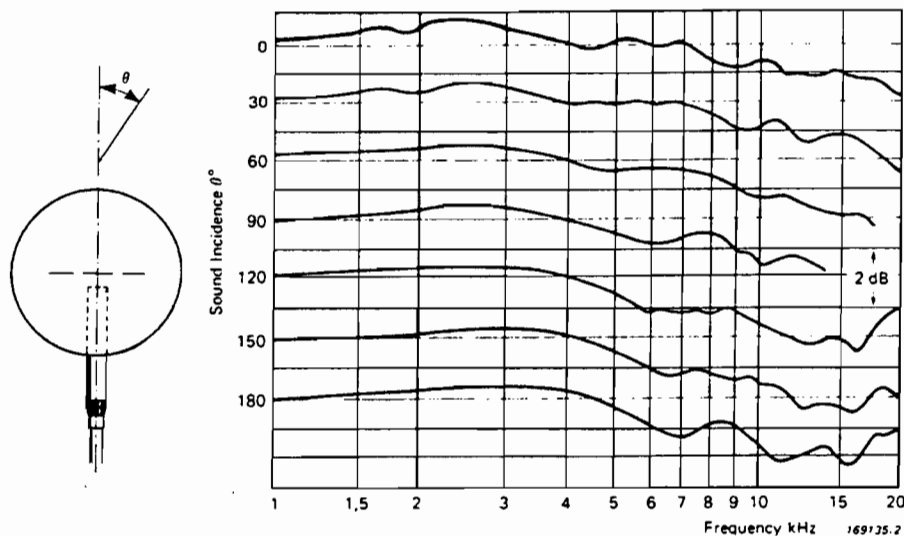

Fig.9.11. Increments to free-field correction curves due to Wind-screen UA 0207

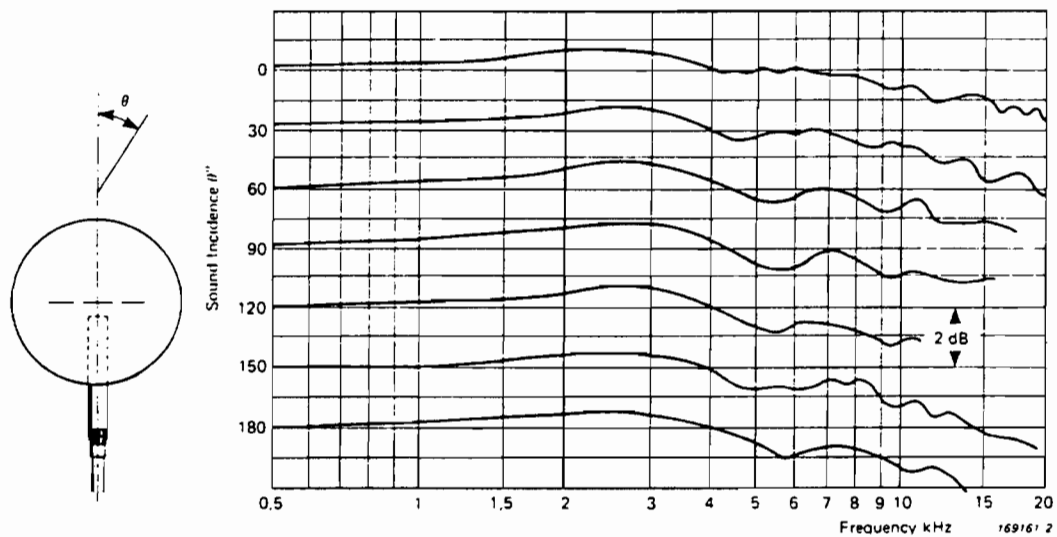

Fig.9.12. Increments to free-field correction curves due to Wind-screen UA 0237

The Windscreen material is a specially prepared type of open-pored polyurethane foam. Diameter is 90 mm and in use the Windscreen is simply pushed as far as it will go over the microphone (fitted with its normal protection grid) and preamplifier. Wind-induced noise for one-inch and half-inch microphones fitted with the foam windscreens is shown in Figs.9.9 and 9.10. Free-field response corrections for the Windscreens are given in Figs.9.11 and 9.12. These curves should be added to the normal free-field characteristic of the microphone.

A smaller (65 mm dia.) Windscreen, UA 0459, is also available. This is briefly described in Section 1.1.

9.3. RAIN COVER UA 0393

A Rain Cover is available only for the half-inch microphone size. The Rain Cover UA 0393, shown in Fig.9.13, is designed to be mounted on a half-inch microphone in place of the normal protection grid, and as well as rain protection, it serves as an electrostatic actuator

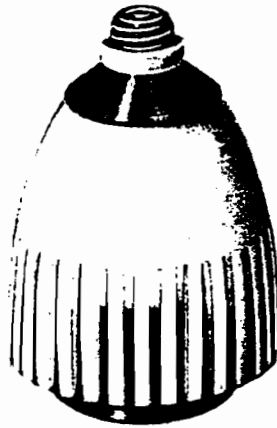

Fig.9.13. Rain Cover UA 0393

calibrator which can be excited for remote calibration. It is important to mount the unit upright, the microphone diaphragm facing straight up. The Rain Cover can be delivered together with a half-inch free-field microphone (4149 is particularly recommended for permanent outdoor use), factory calibrated to give an equivalent sound pressure level of 90 ± 1 dB when 215 V AC is applied to the actuator terminal (80 ± 1 dB for 121 V AC).

Free-field corrections of the half-inch microphones fitted with the Rain Cover are given in Fig.9.14. From these curves, the response of the half-inch microphone can be drawn as shown in Fig.9.15.

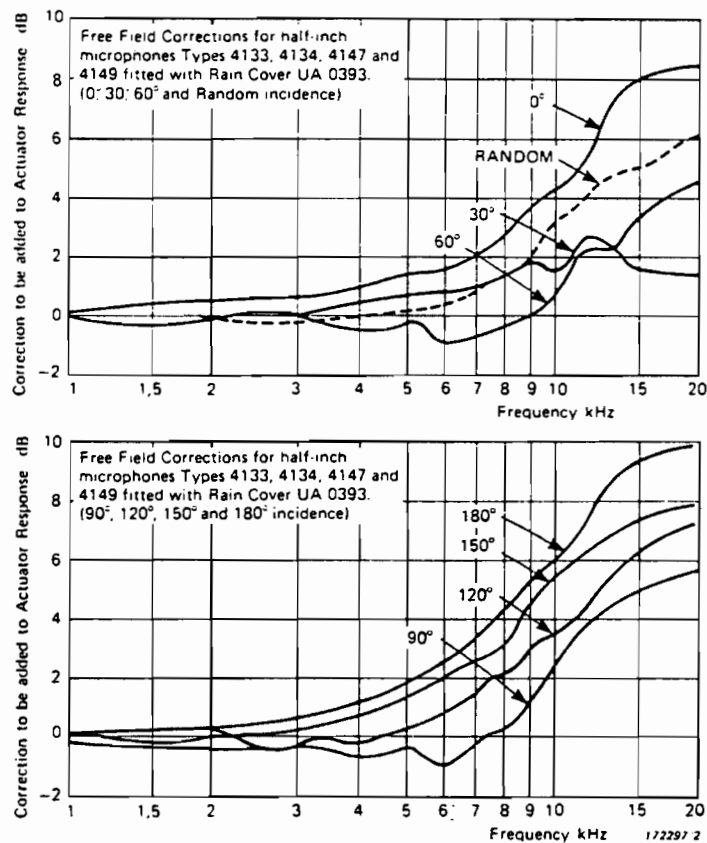

Fig.9.14. Free-field correction curves for half-inch microphones Types 4133 and 4149 fitted with Rain Cover UA 0393

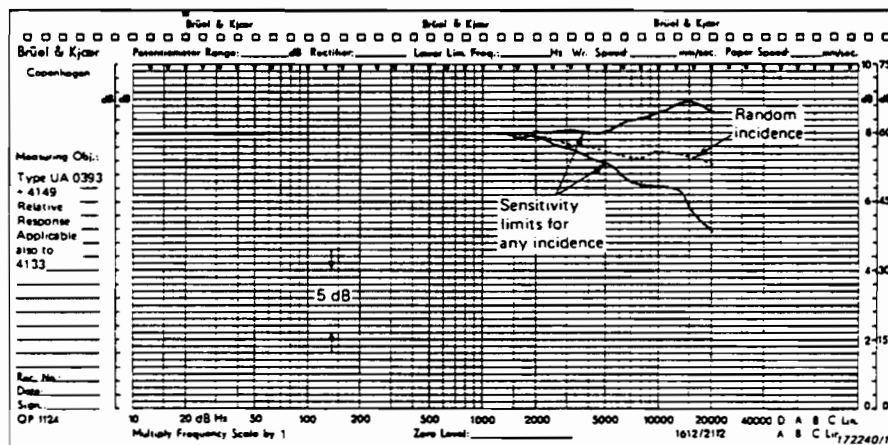

Fig.9.15. Sensitivity limits for any incidence for half-inch microphones Types 4133 and 4149 fitted Rain Cover UA 0393

A particularly recommended outdoor installation, suitable for use in all weathers, is a 4149 microphone fitted with UA 0393 Rain Cover, UA 0308 dehumidifier (section 1.1), and Windscreen UA 0570 (section 9.2.1). This combination also meets the directional requirements of IEC 651 Type 1 for precision sound level measurements. The microphone is best protected in such an outdoor application when the preamplifier heater is permanently on.

Maximum temperature to which the Rain Cover should be subjected is 150°C.

Note that the electrostatic actuator of the Rain Cover is not recommended for frequency response calibration because the presence of the Rain Cover itself influences the linearity of the frequency characteristics at high frequencies.

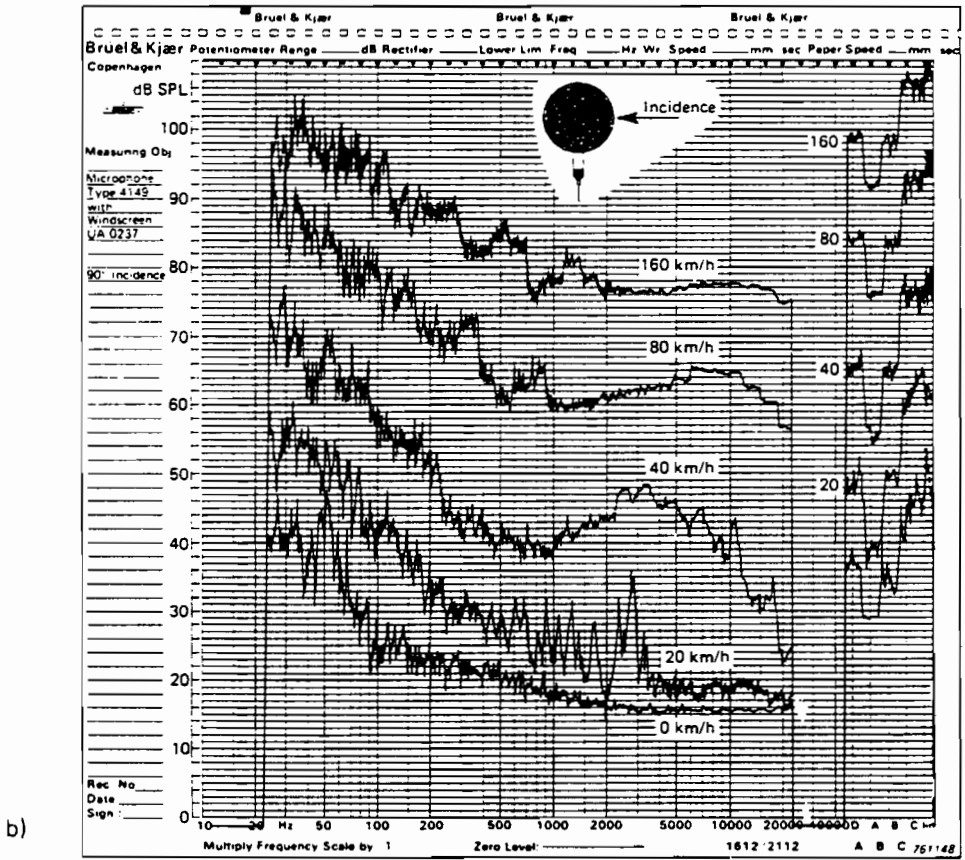
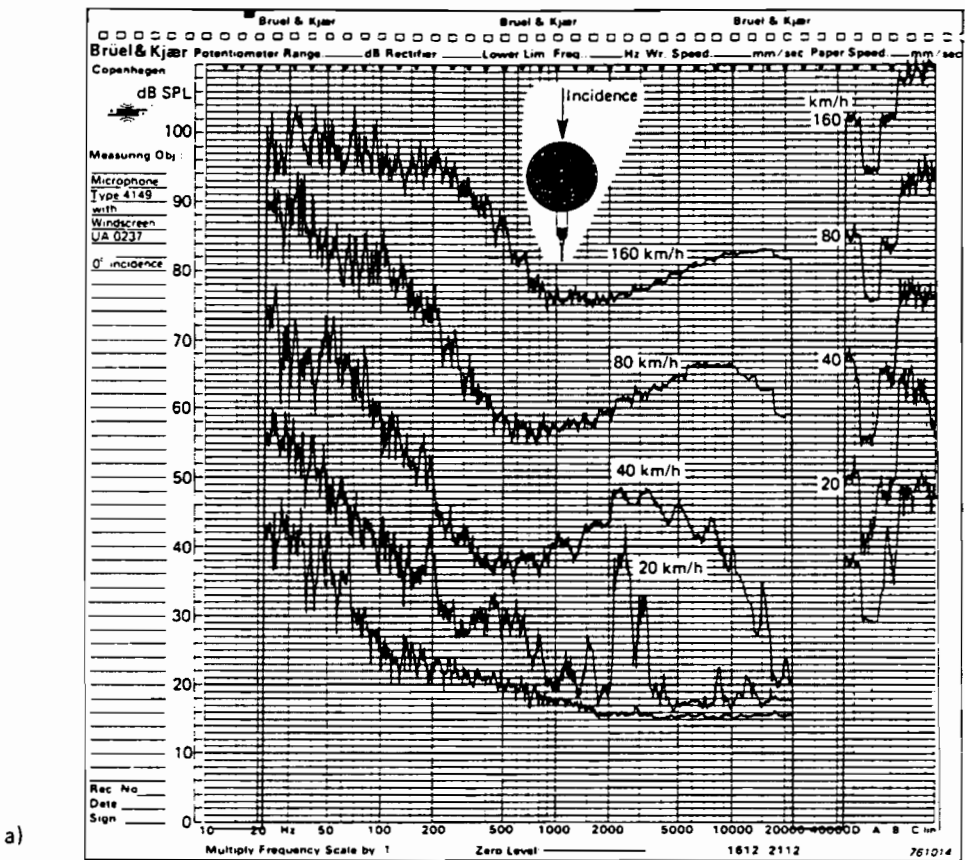
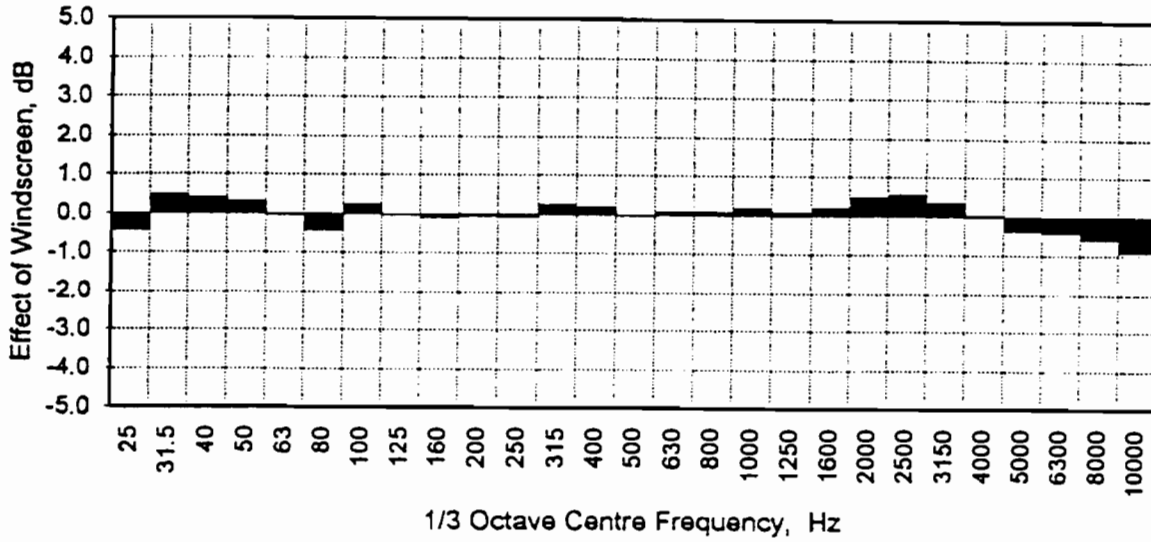

Fig.9.10. Wind induced noise levels for half-inch microphones fitted with Windscreen UA 0237
 a) 0° incidence b) 90° incidence

Appendix C

**One-third octave band spectra showing effect of
windscreens on free-field frequency response
of 4155 microphone (90° incidence)**

Outer Windscreen : None
Inner Windscreen : B&K UA0237



Outer Windscreen : None
Inner Windscreen : B&K UA0570/UA0393

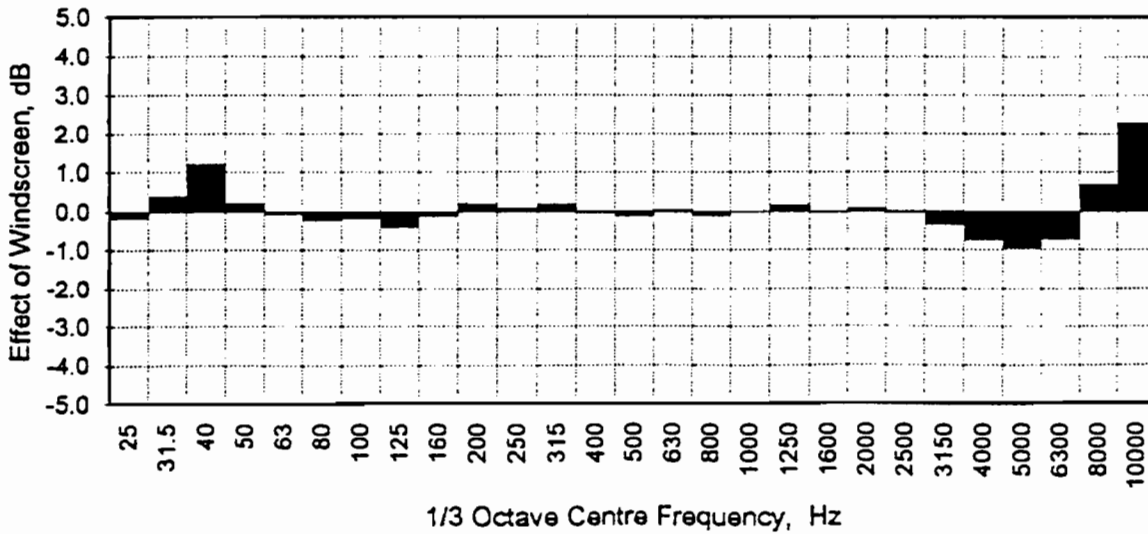

Outer Windscreen : Diameter 200 mm Solid Foam Grade 10 ppi
 Inner Windscreen : None

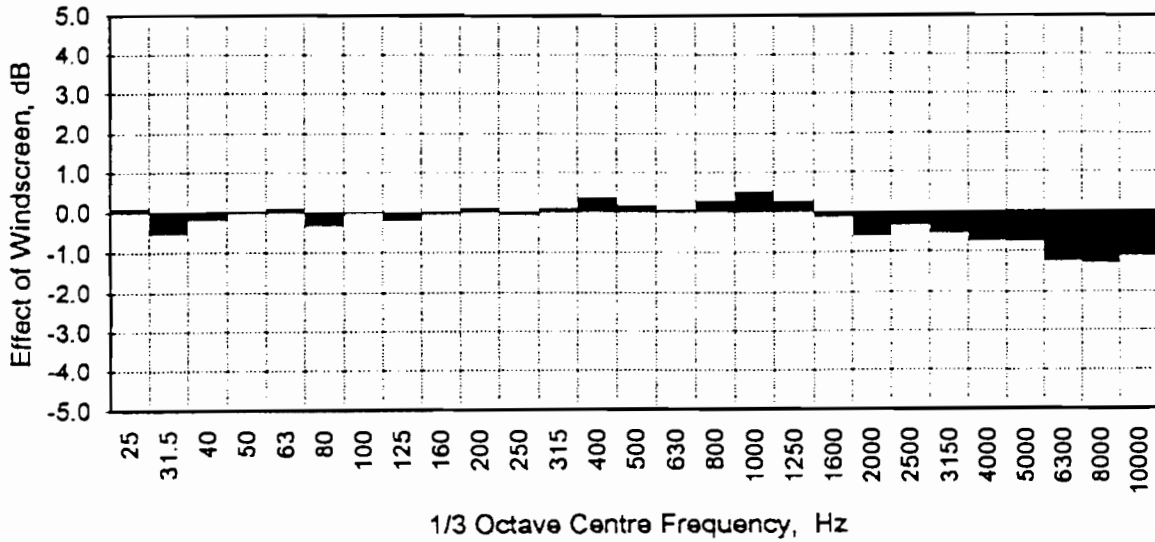

Outer Windscreen : Diameter 200 mm Solid Foam Grade 20 ppi
 Inner Windscreen : None

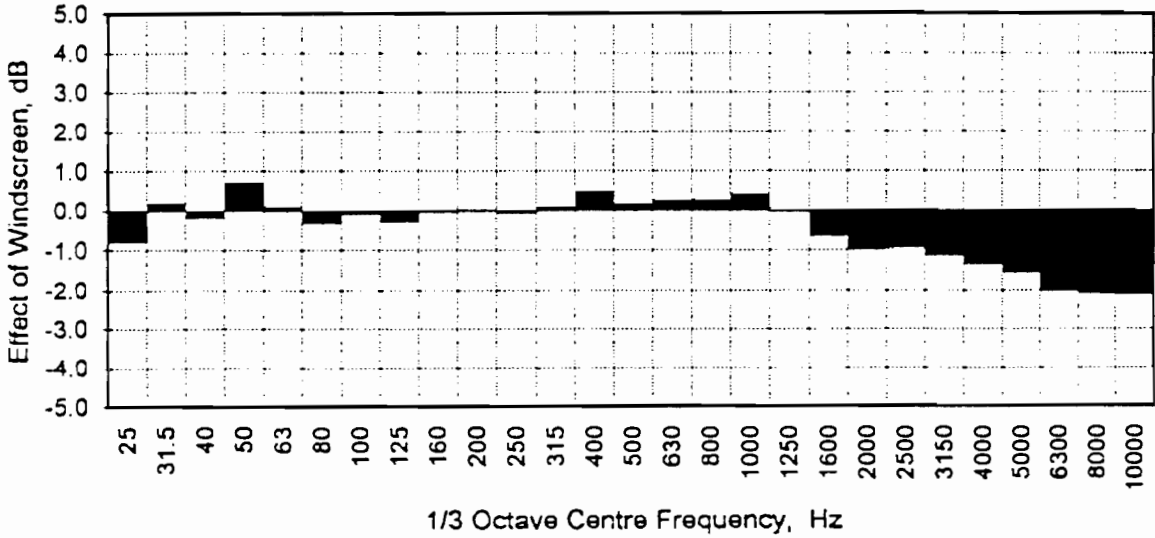

Outer Windscreen : Diameter 200 mm Solid Foam Grade 30 ppi
 Inner Windscreen : None

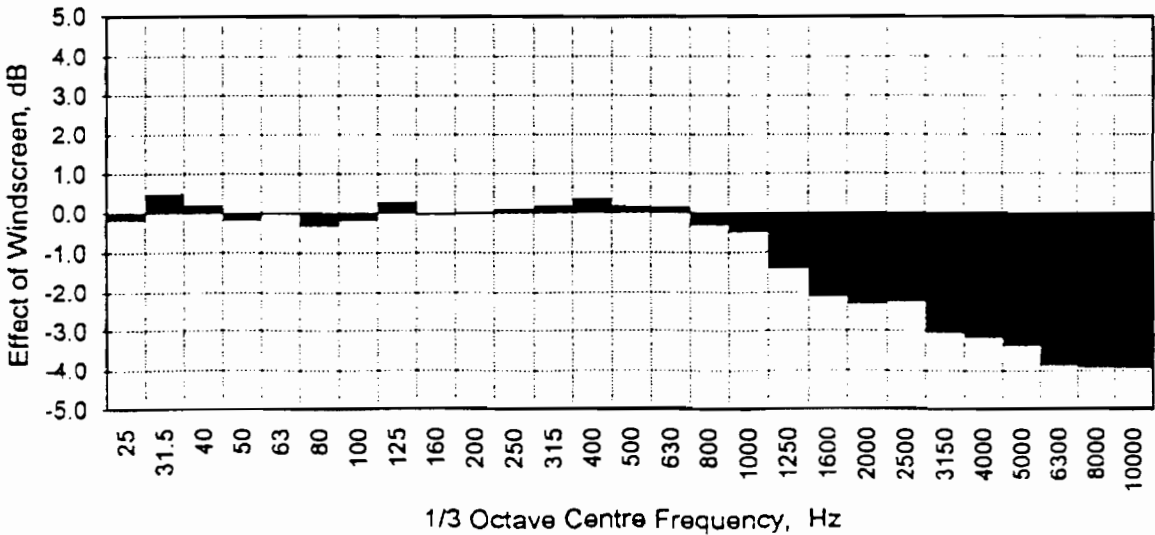

Outer Windscreen : Diameter 200 mm Solid Foam Grade 45 ppi
 Inner Windscreen : None

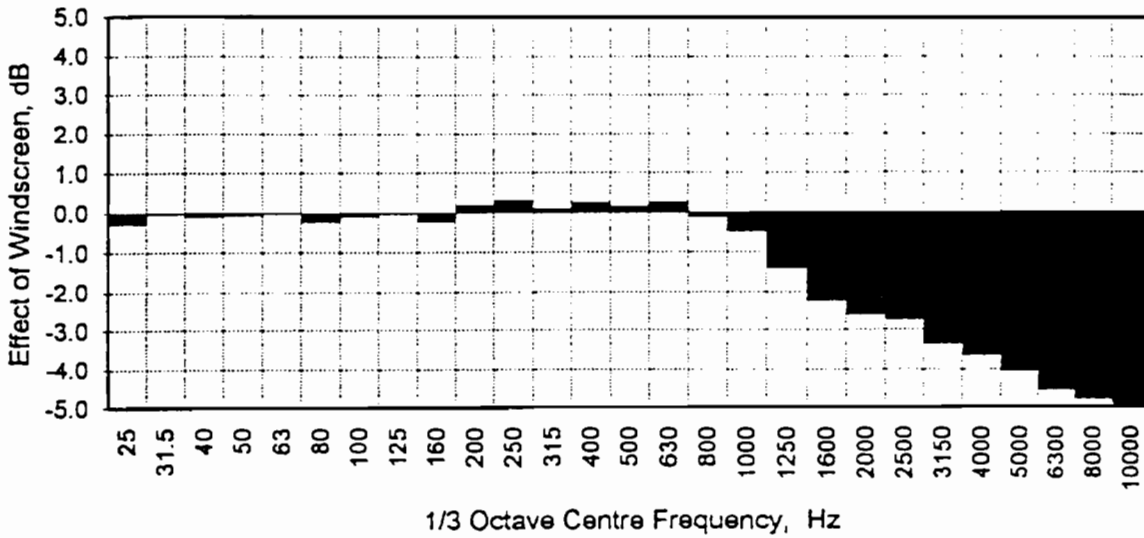

Outer Windscreen : Diameter 200 mm Solid Foam Grade 60 ppi
 Inner Windscreen : None

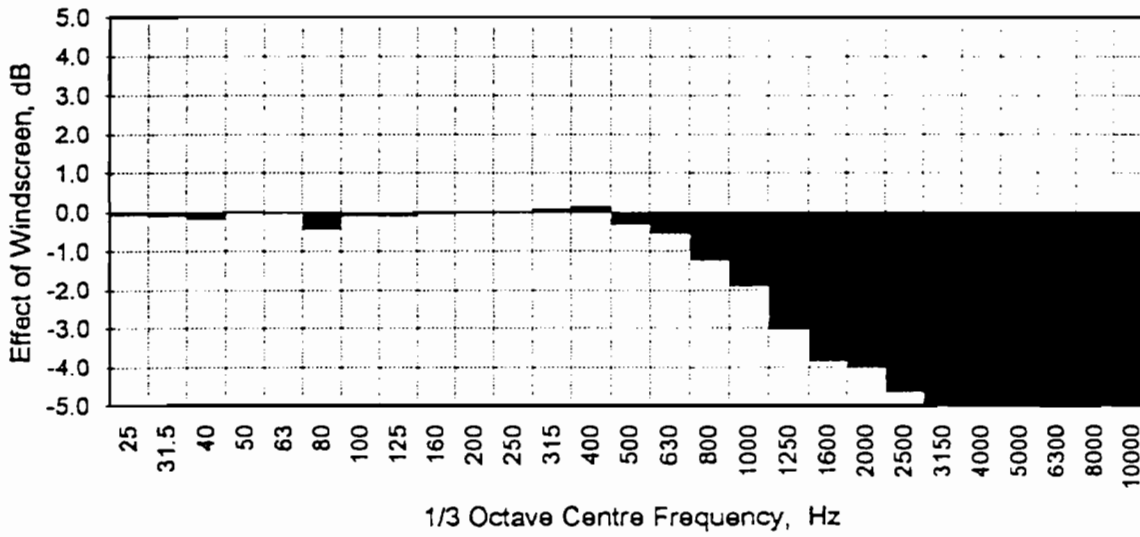

Outer Windscreen : Diameter 200 mm Solid Foam Grade 70 ppi
 Inner Windscreen : None

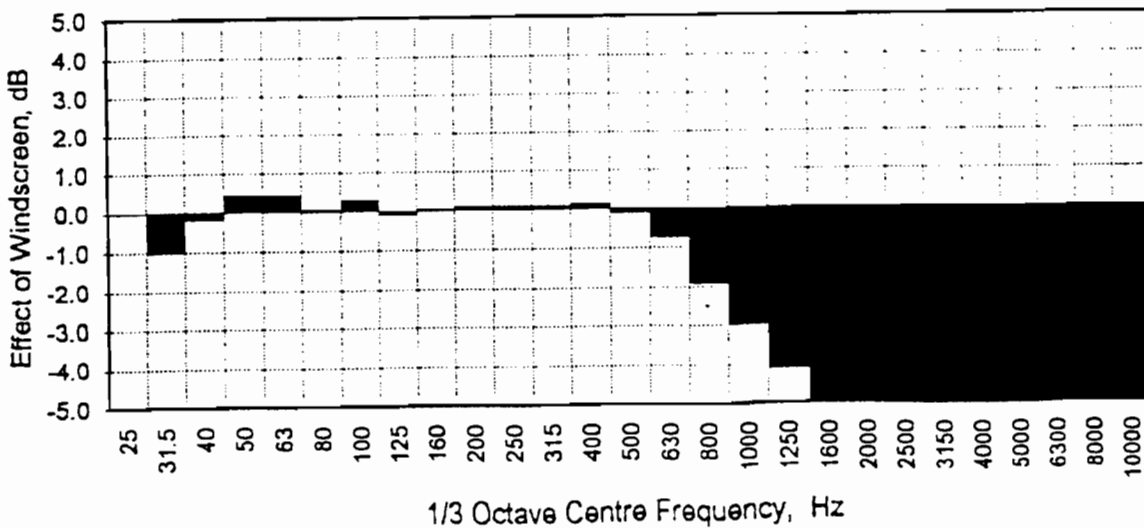

Outer Windscreen : Diameter 300 mm Solid Foam Grade 10 ppi
Inner Windscreen : None

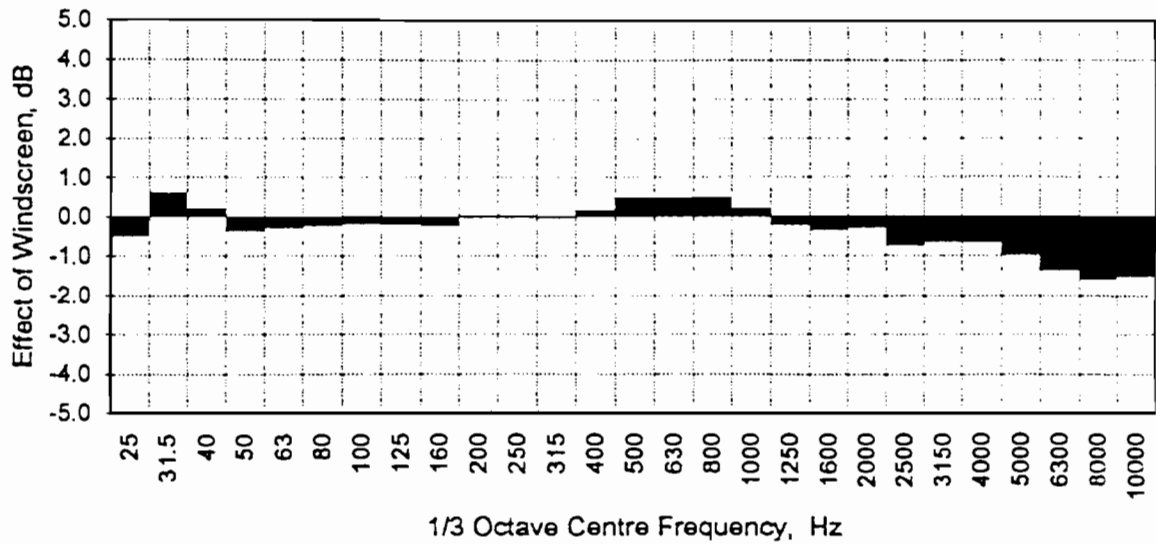

Outer Windscreen : Diameter 300 mm Solid Foam Grade 20 ppi
Inner Windscreen : None

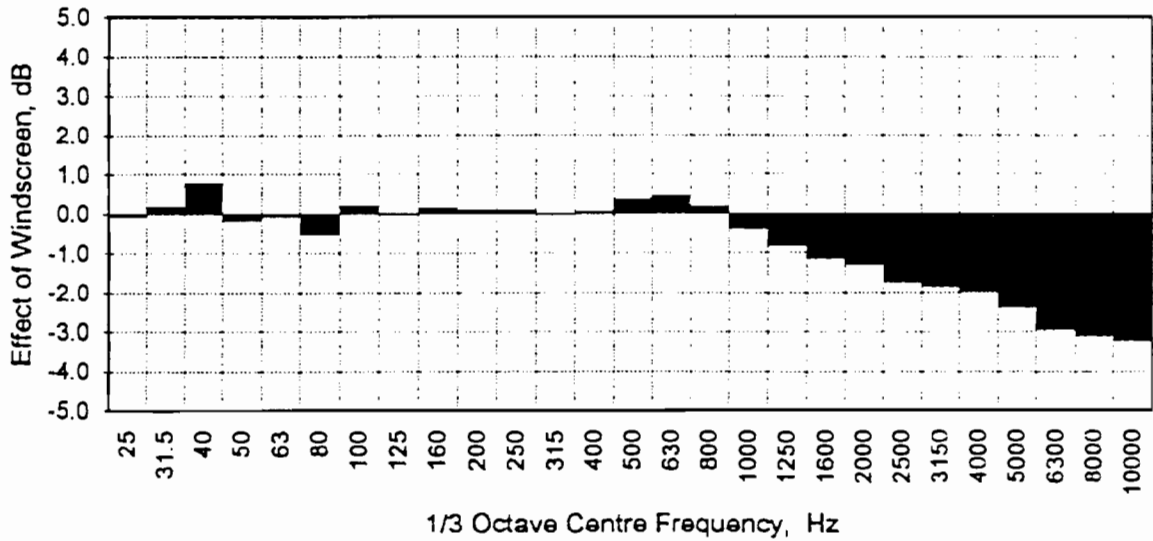

Outer Windscreen : Diameter 300 mm Solid Foam Grade 30 ppi
Inner Windscreen : None

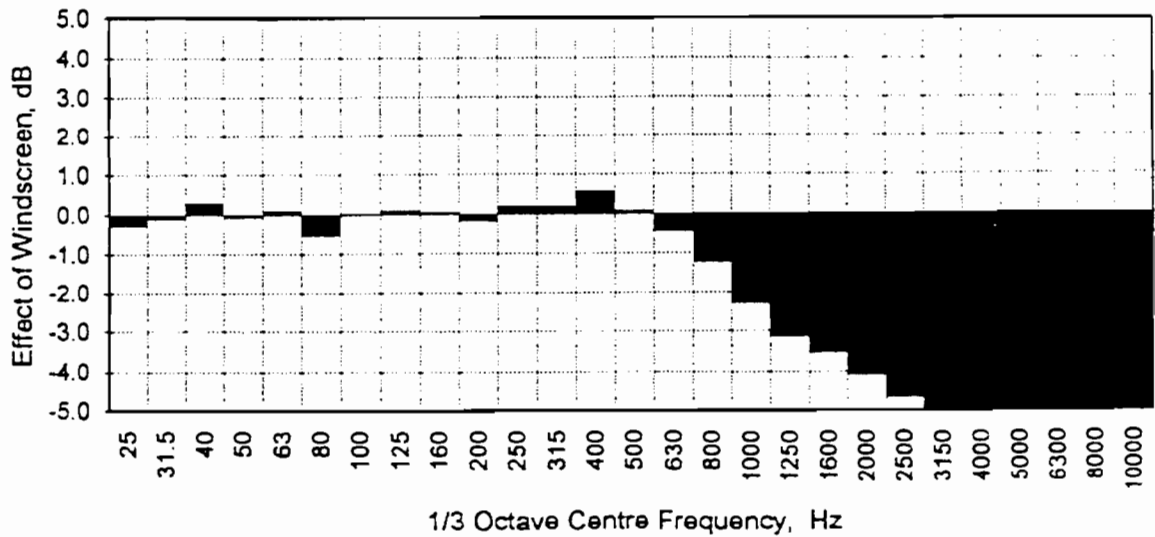

Outer Windscreen : Diameter 300 mm Solid Foam Grade 45 ppi
 Inner Windscreen : None

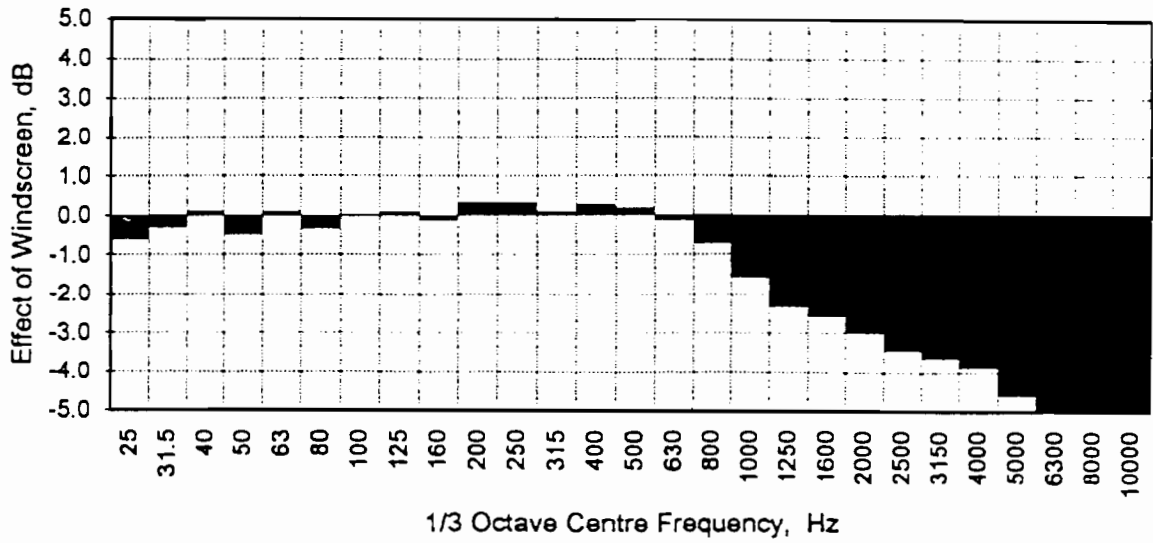

Outer Windscreen : Diameter 300 mm Solid Foam Grade 60 ppi
 Inner Windscreen : None

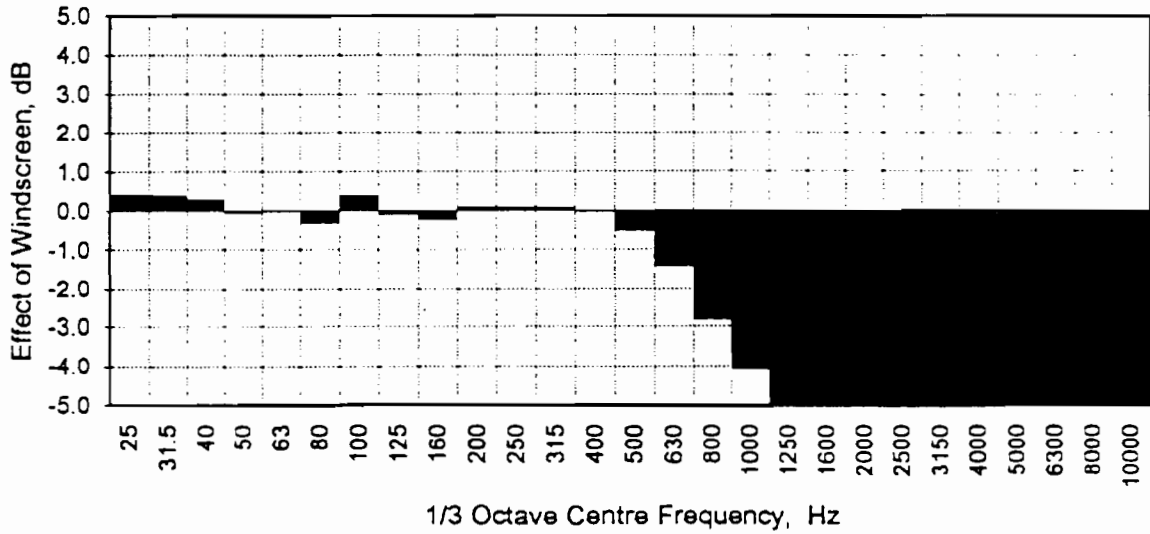

Outer Windscreen : Diameter 300 mm Solid Foam Grade 80 ppi
 Inner Windscreen : None

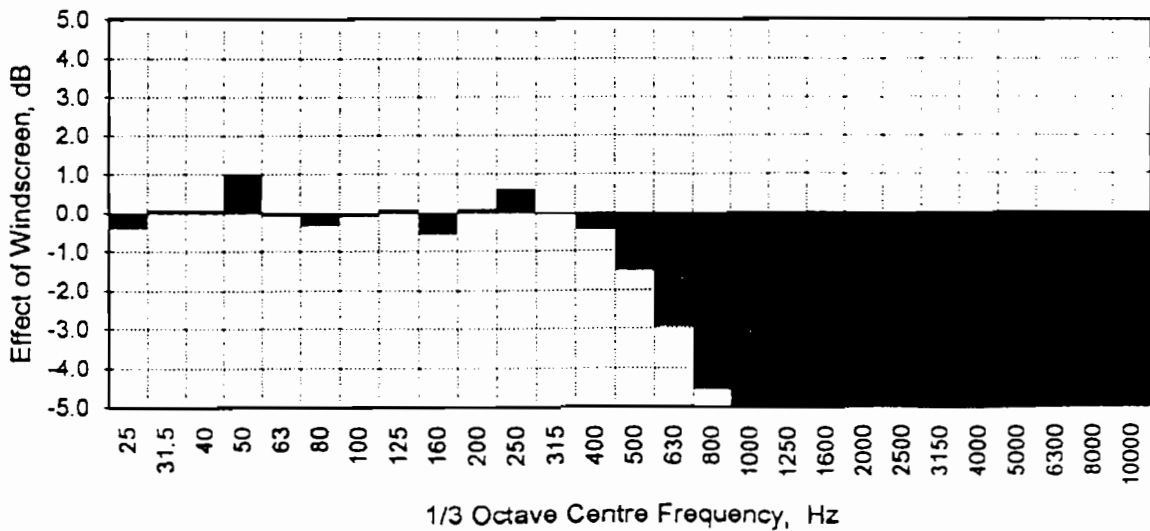

Outer Windscreen : Diameter 200 mm Hollow Foam Grade 10 ppi
 Inner Windscreen : None

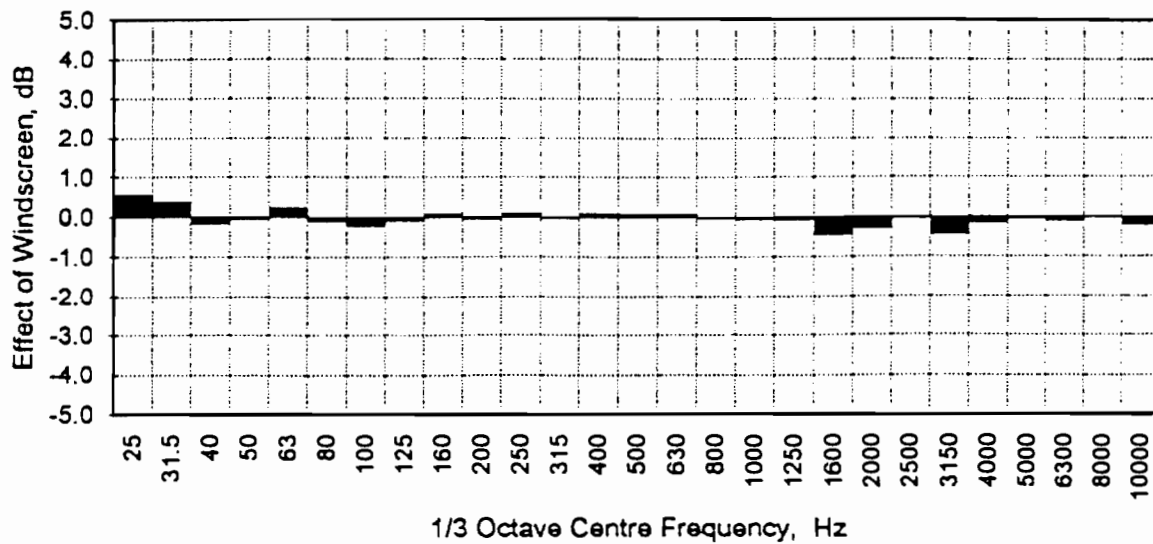

Outer Windscreen : Diameter 200 mm Hollow Foam Grade 20 ppi
 Inner Windscreen : None

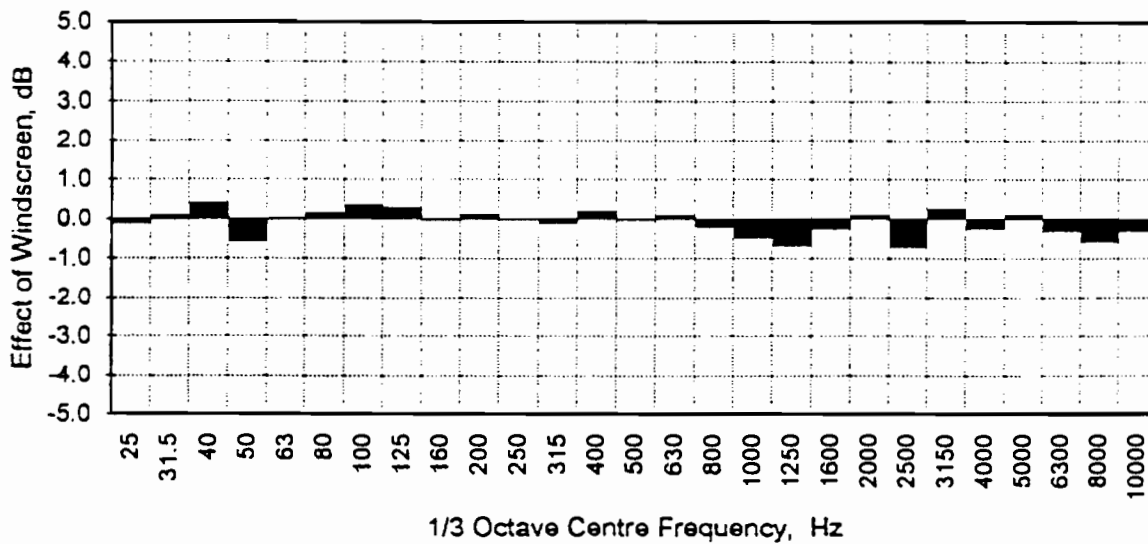

Outer Windscreen : Diameter 200 mm Hollow Foam Grade 30 ppi
 Inner Windscreen : None

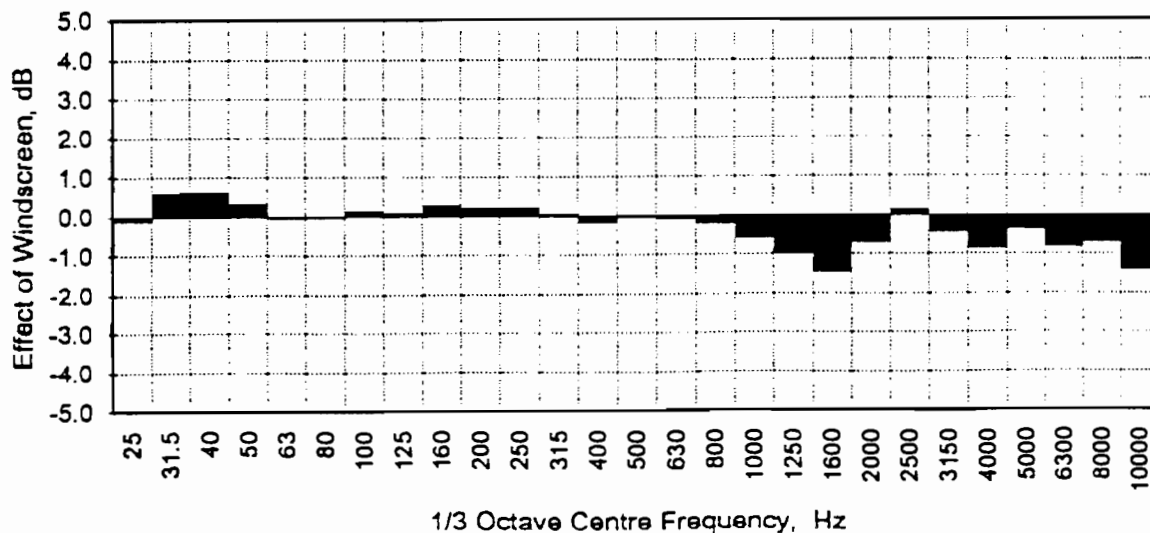

Outer Windscreen : Diameter 200 mm Hollow Foam Grade 45 ppi
Inner Windscreen : None

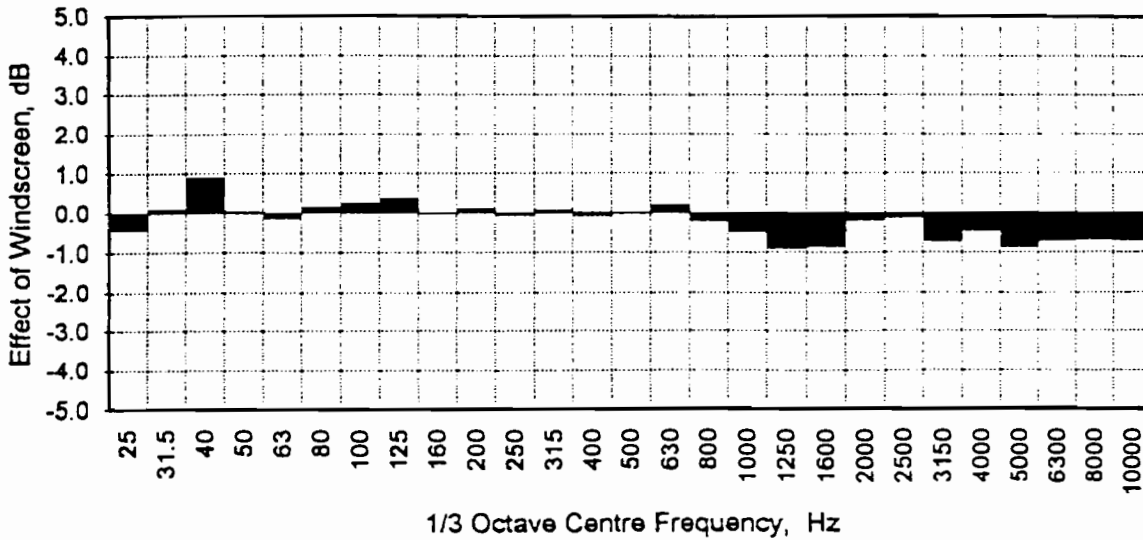

Outer Windscreen : Diameter 200 mm Hollow Foam Grade 60 ppi
Inner Windscreen : None

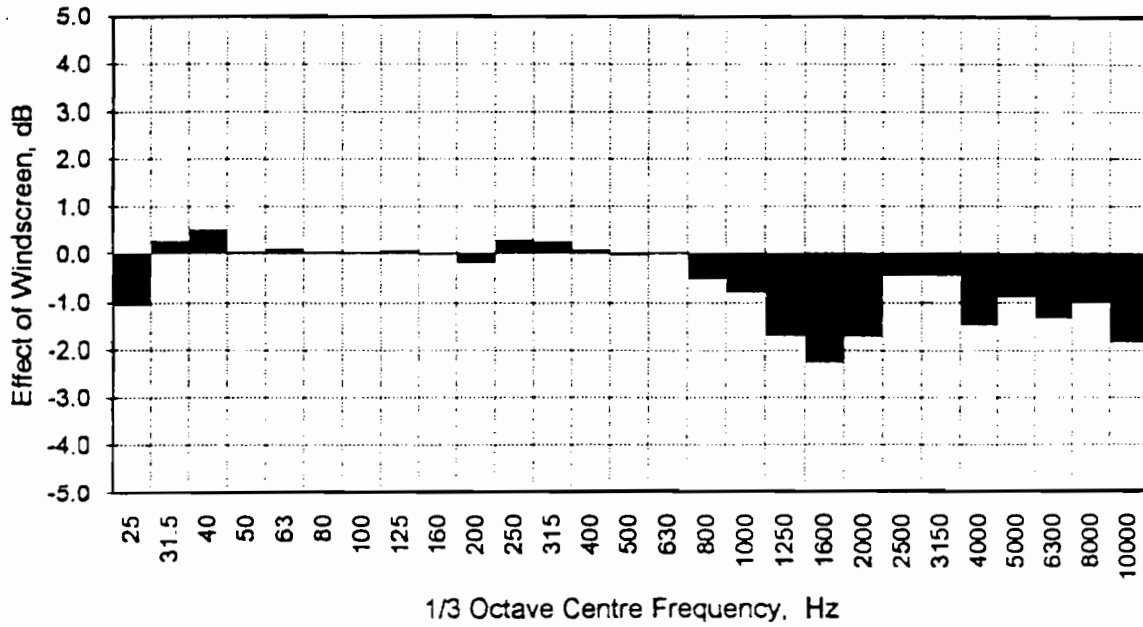

Outer Windscreen : Diameter 200 mm Hollow Foam Grade 80 ppi
Inner Windscreen : None

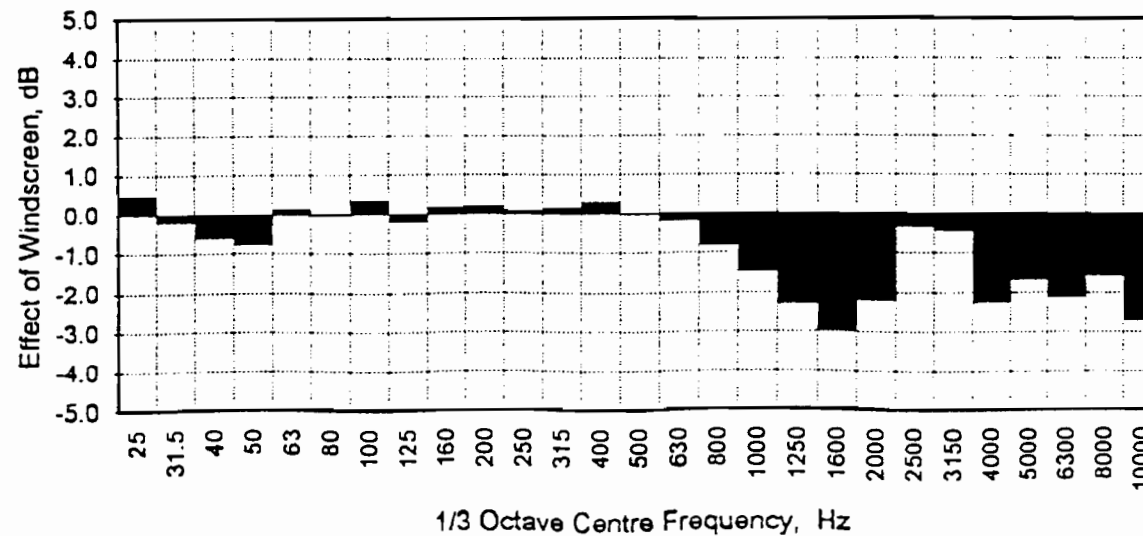

Outer Windscreen : Diameter ~~200~~ 400 mm Hollow Foam Grade 10 ppi
 Inner Windscreen : B&K UA0237

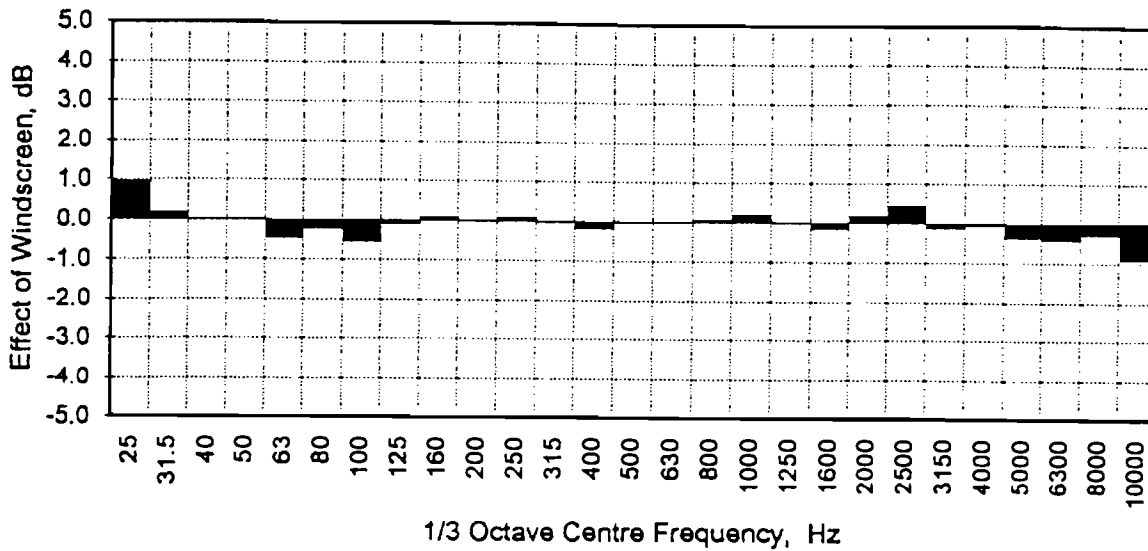

Outer Windscreen : Diameter 200 mm Hollow Foam Grade 30 ppi
 Inner Windscreen : B&K UA0237

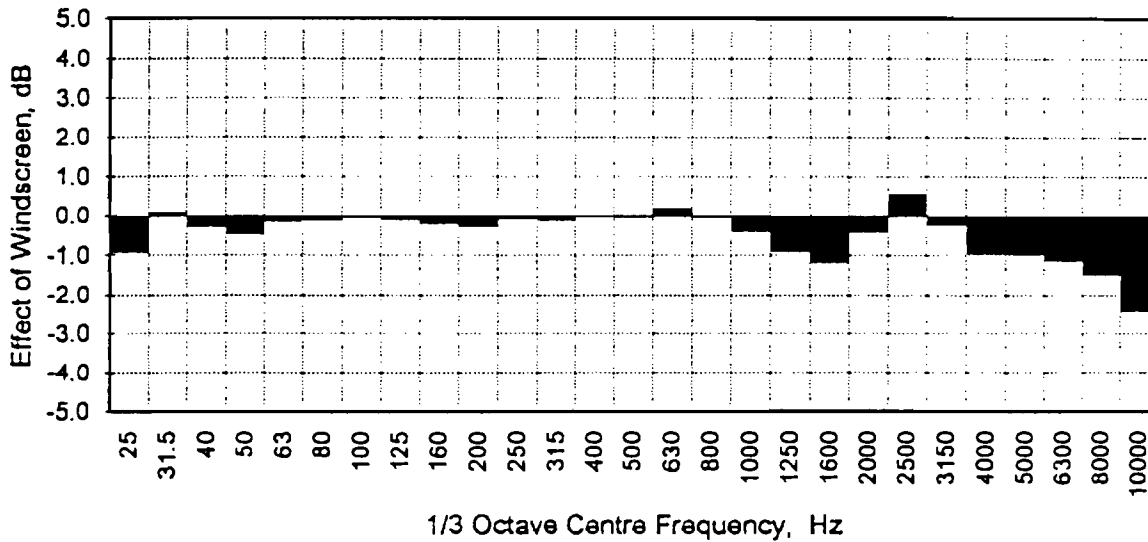

Outer Windscreen : Diameter 200 mm Hollow Foam Grade 20 ppi
 Inner Windscreen : B&K UA0237

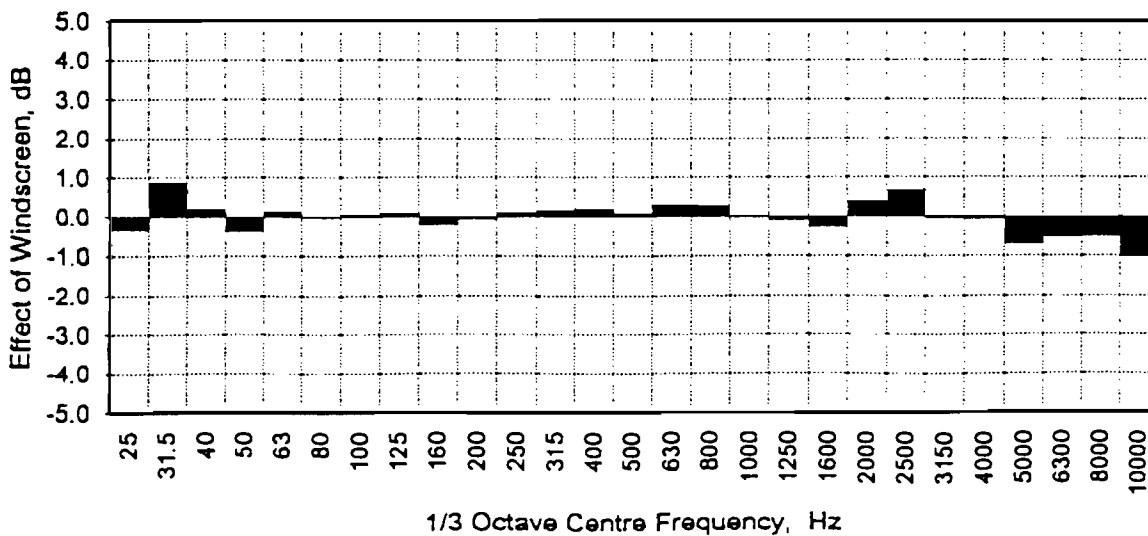

Outer Windscreen : Diameter 200 mm Hollow Foam Grade 45 ppi
 Inner Windscreen : B&K UA0237

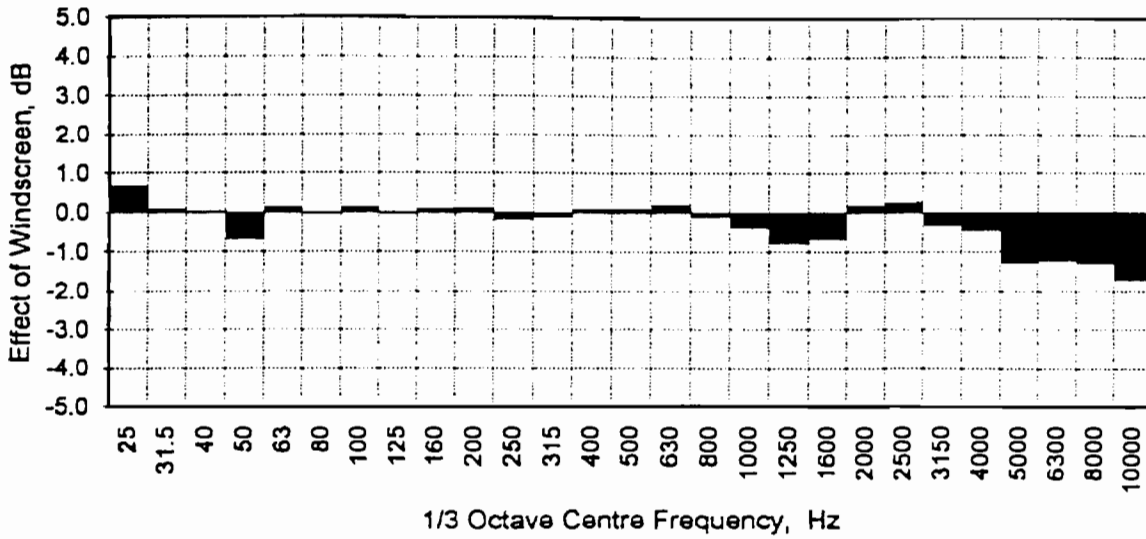

Outer Windscreen : Diameter 200 mm Hollow Foam Grade 60 ppi
 Inner Windscreen : B&K UA0237

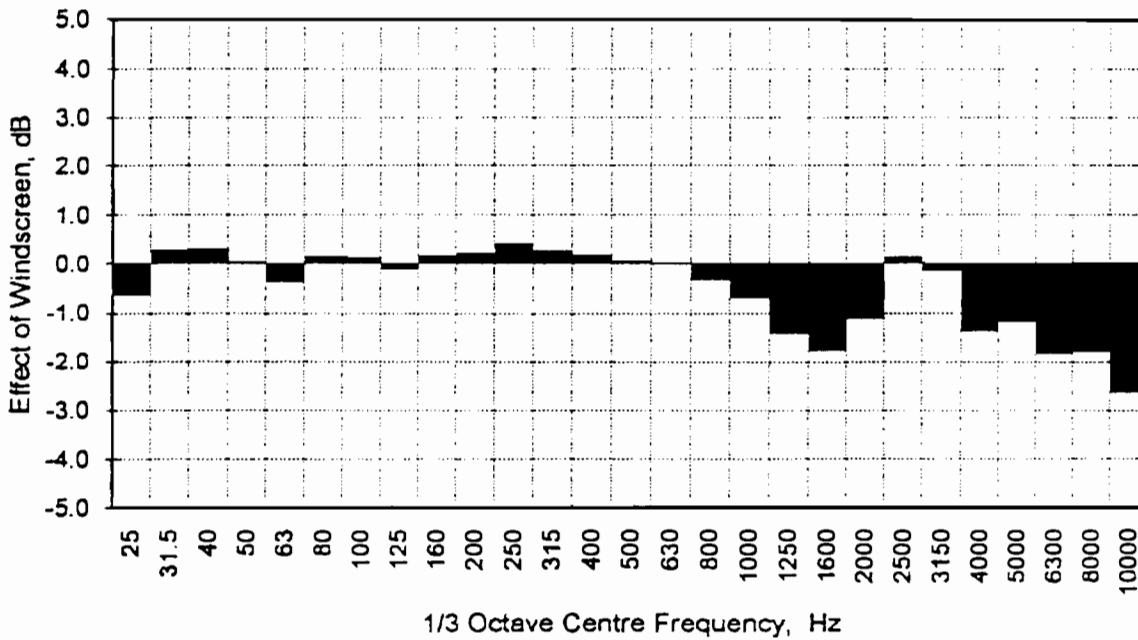

Outer Windscreen : Diameter 200 mm Hollow Foam Grade 80 ppi
 Inner Windscreen : B&K UA0237

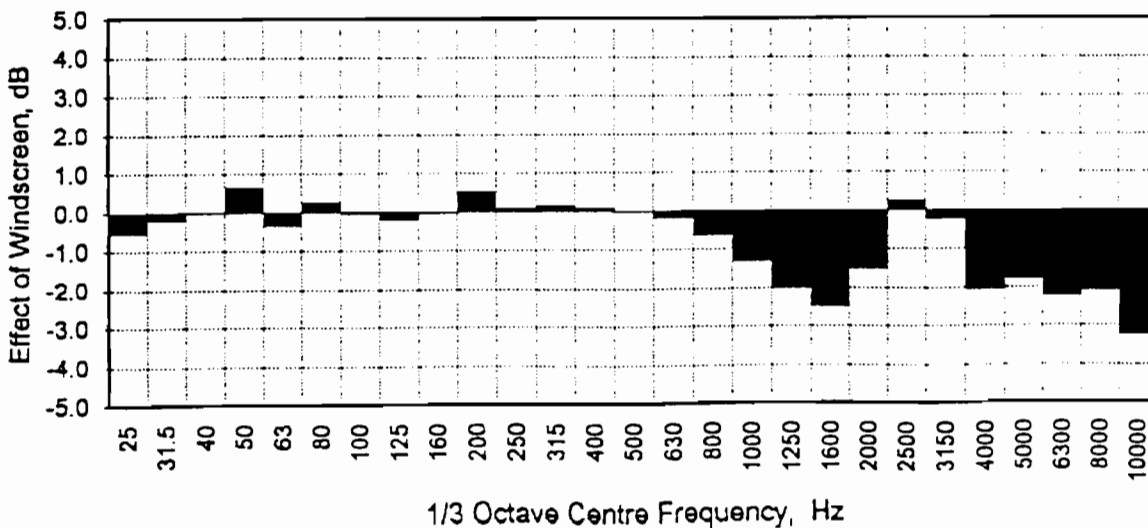

Outer Windscreen : Diameter 200 mm Hollow Foam Grade 10 ppi
 Inner Windscreen : B&K UA0570/UA0393

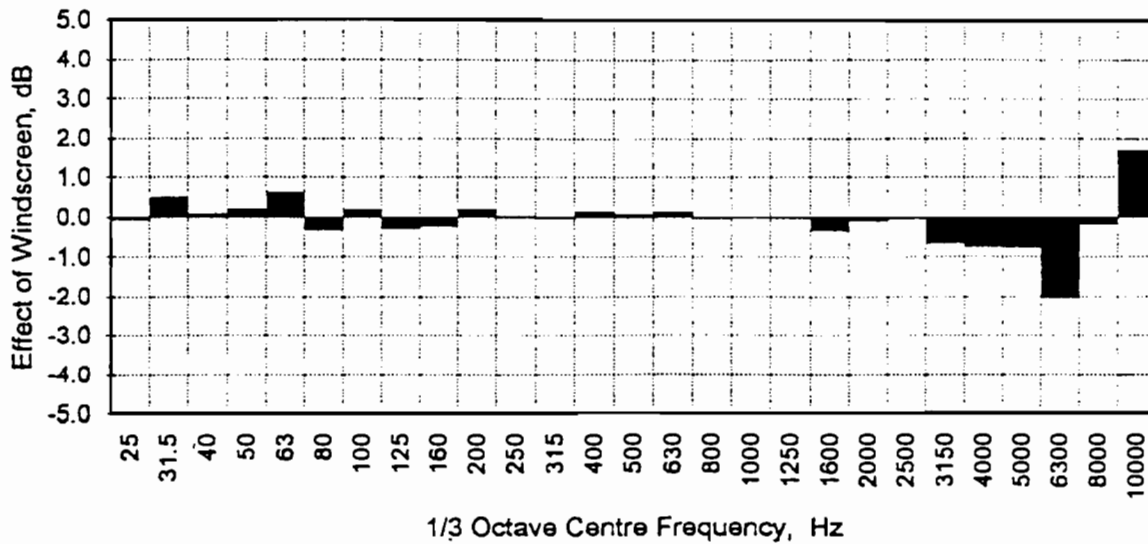

Outer Windscreen : Diameter 200 mm Hollow Foam Grade 20 ppi
 Inner Windscreen : B&K UA0570/UA0393

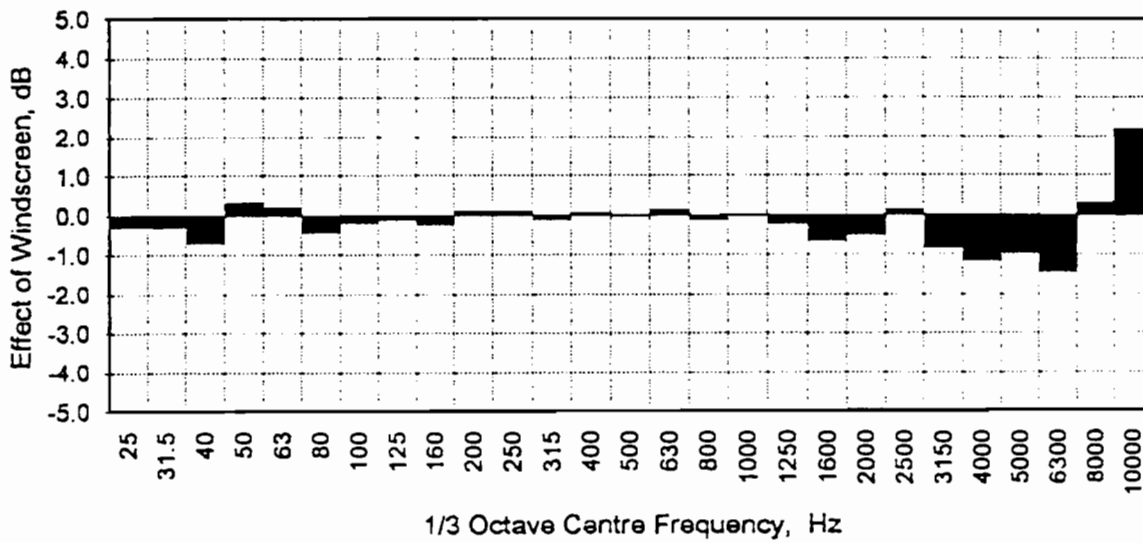

Outer Windscreen : Diameter 200 mm Hollow Foam Grade 30 ppi
 Inner Windscreen : B&K UA0570/UA0393

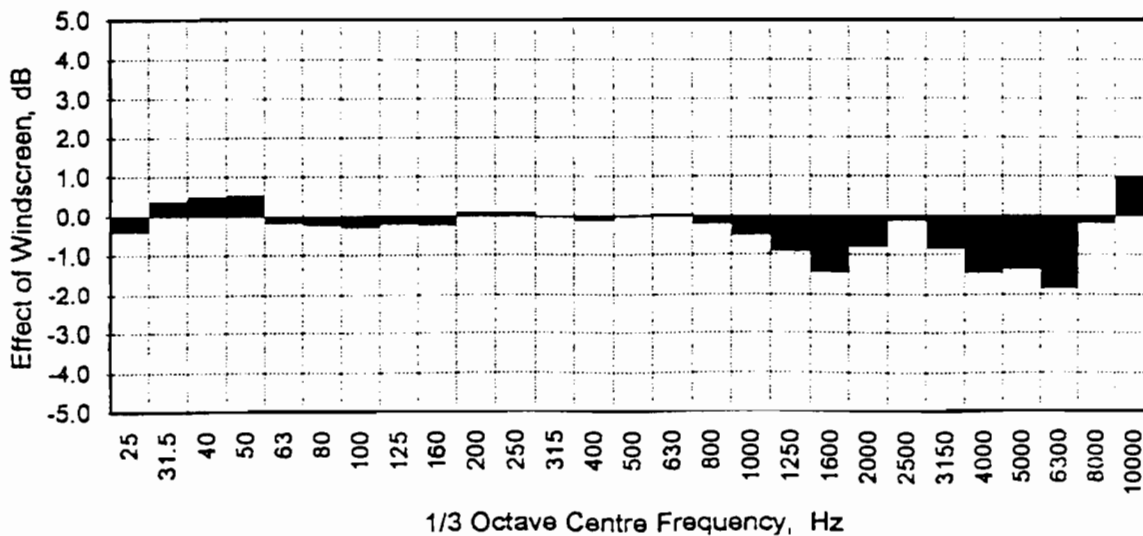

Outer Windscreen : Diameter 200 mm Hollow Foam Grade 45 ppi
 Inner Windscreen : B&K UA0570/UA0393

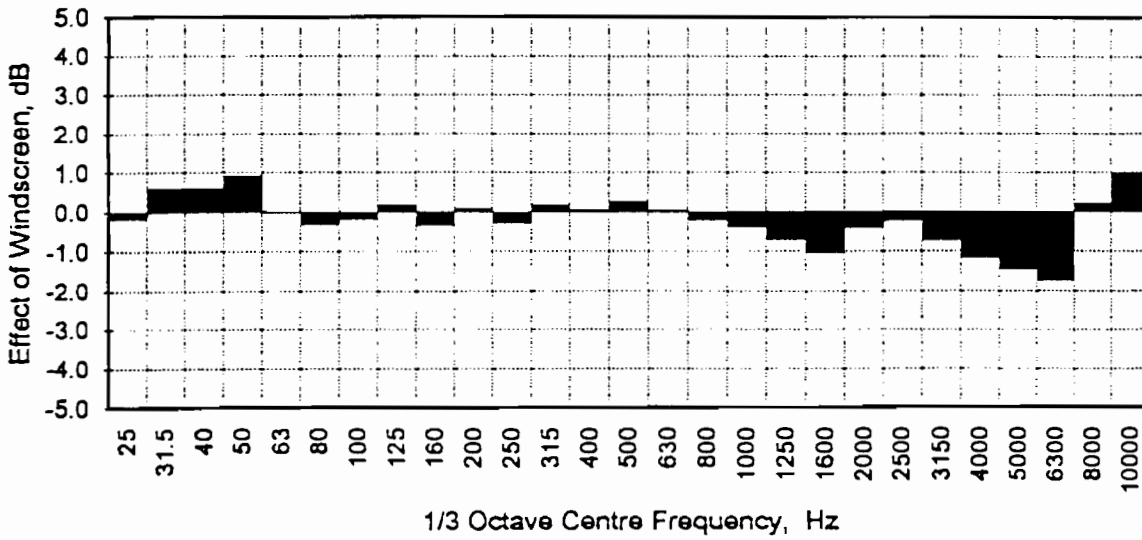

A

Outer Windscreen : Diameter 200 mm Hollow Foam Grade 60 ppi
 Inner Windscreen : B&K UA0570/UA0393

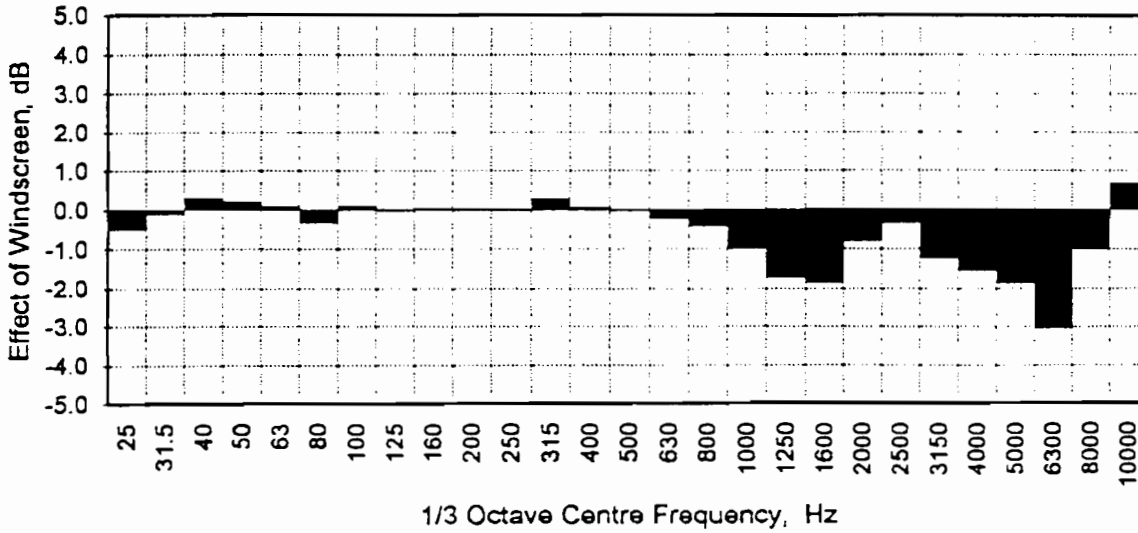

Outer Windscreen : Diameter 200 mm Hollow Foam Grade 80 ppi
 Inner Windscreen : B&K UA0570/UA0393

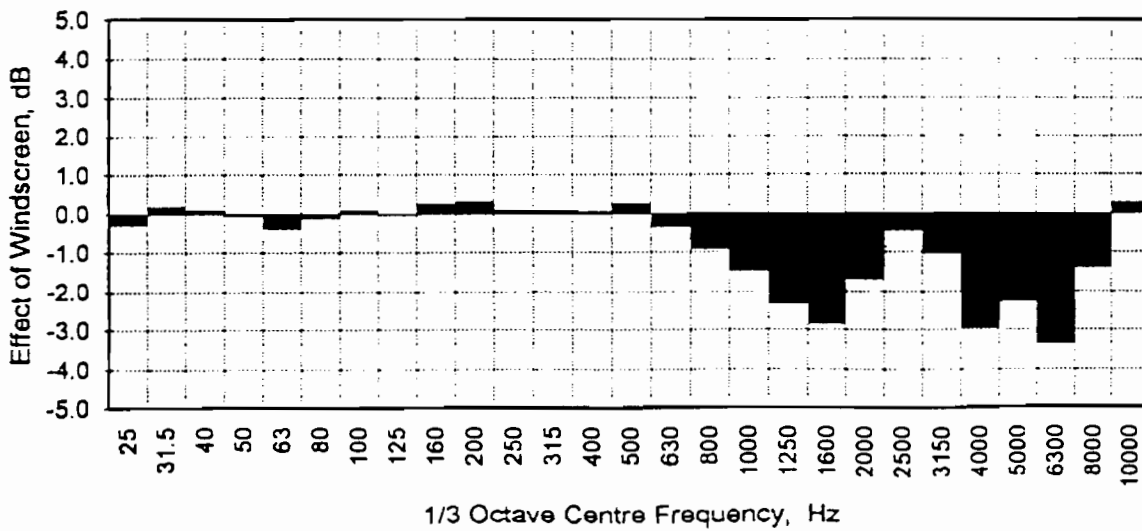

Outer Windscreen : Diameter 300 mm Hollow Foam Grade 10 ppi
 Inner Windscreen : None

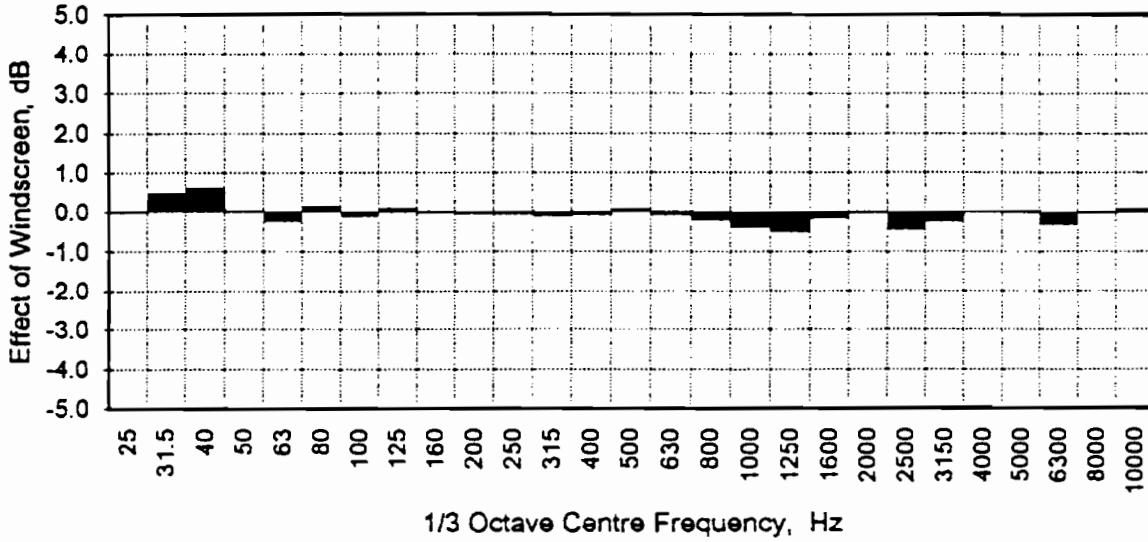

Outer Windscreen : Diameter 300 mm Hollow Foam Grade 30 ppi
 Inner Windscreen : None

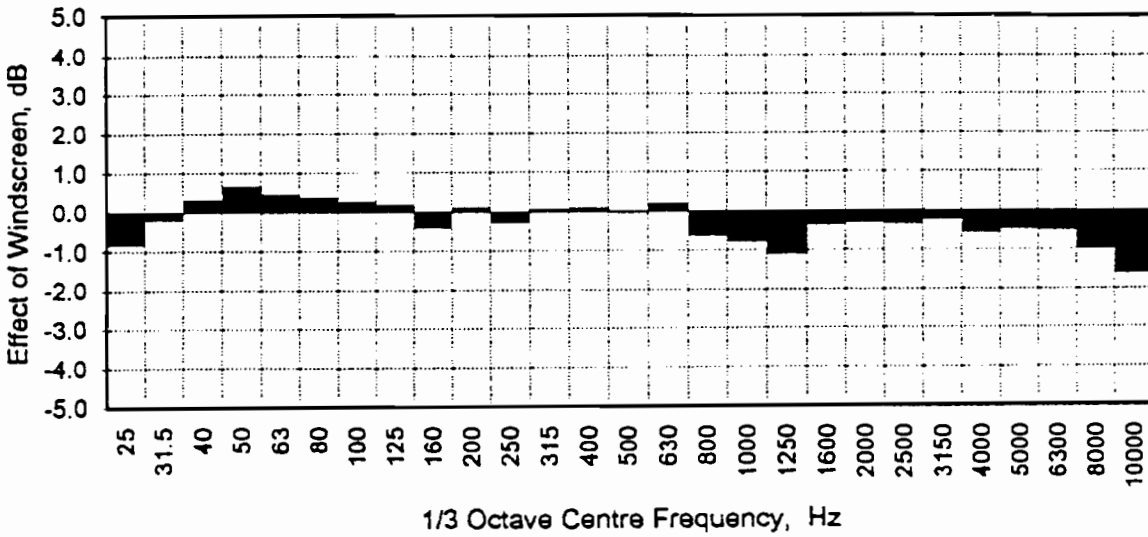

Outer Windscreen : Diameter 300 mm Hollow Foam Grade 45 ppi
 Inner Windscreen : None

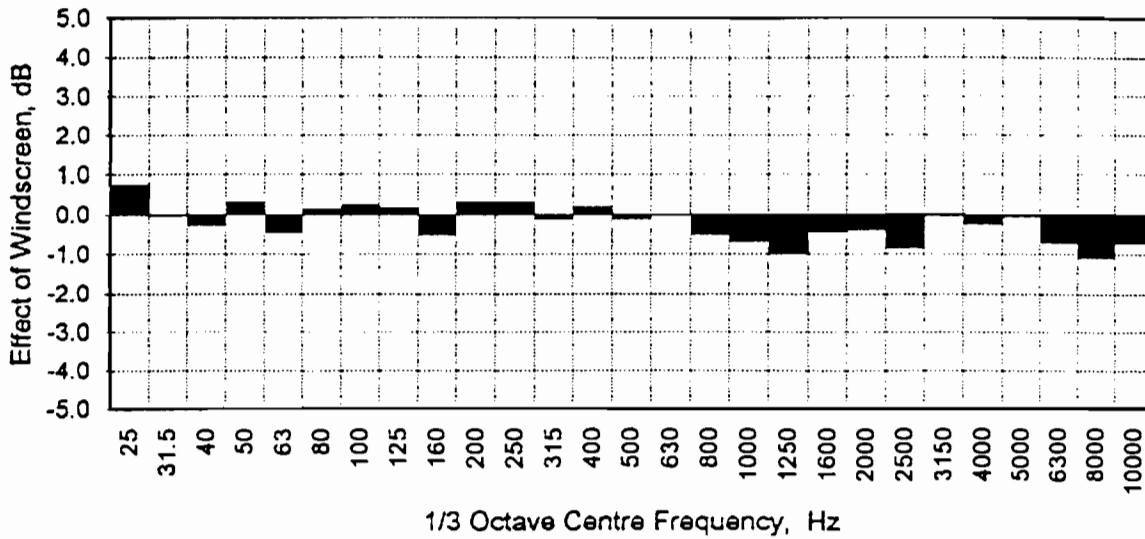

Outer Windscreen : Diameter 300 mm Hollow Foam Grade 60 ppi
 Inner Windscreen : None

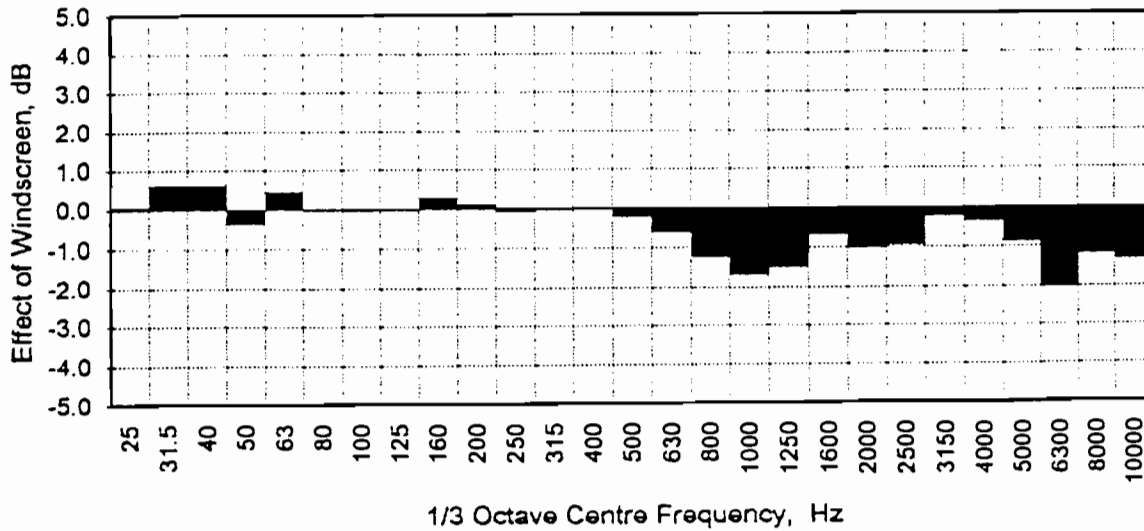

Outer Windscreen : Diameter 300 mm Hollow Foam Grade 80 ppi
 Inner Windscreen : None

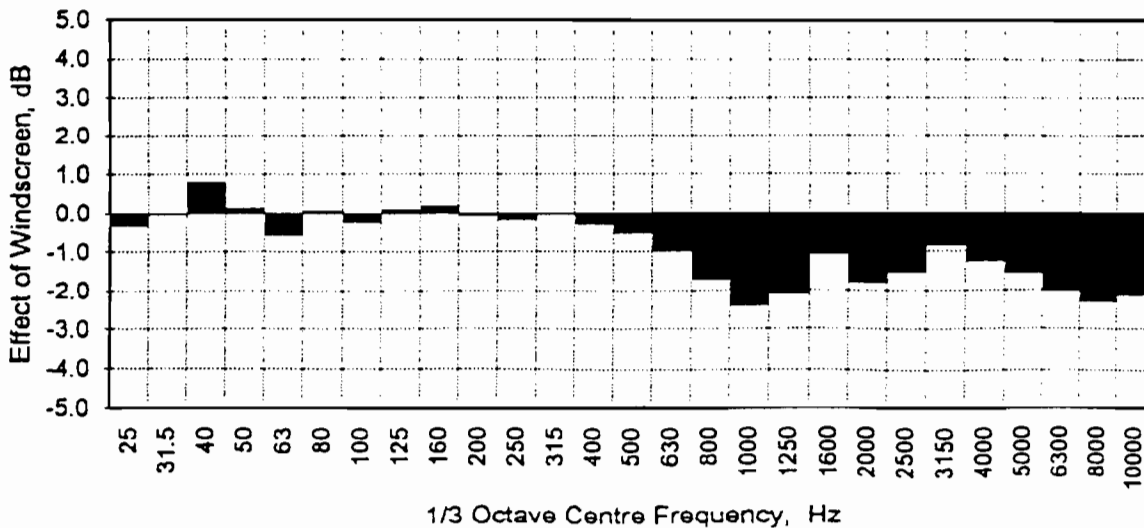

Outer Windscreen : Diameter 300 mm Hollow Foam Grade 10 ppi
 Inner Windscreen : B&K UA0237

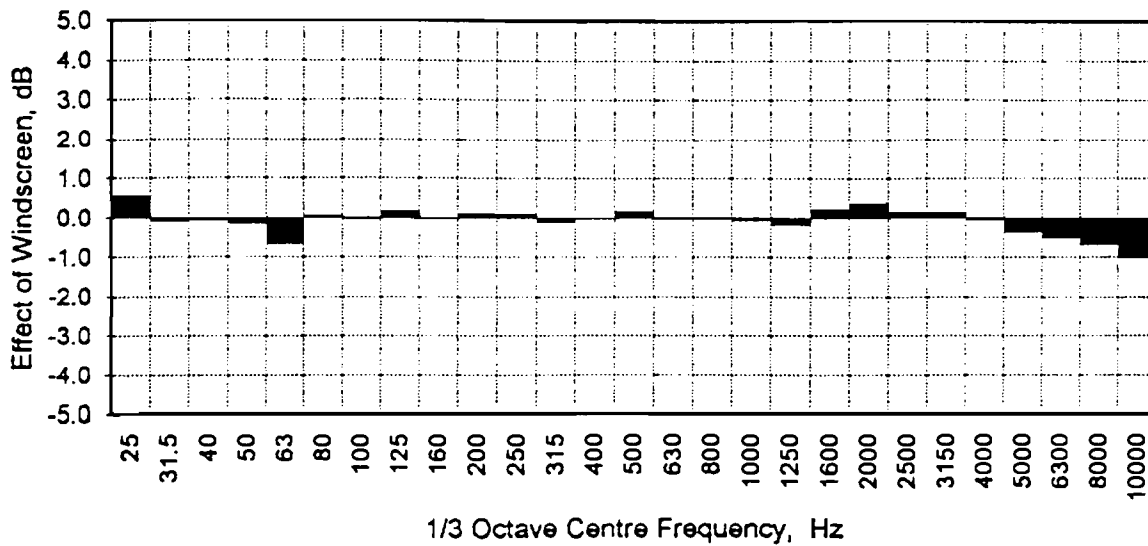

Outer Windscreen : Diameter 300 mm Hollow Foam Grade 20 ppi
 Inner Windscreen : B&K UA0237

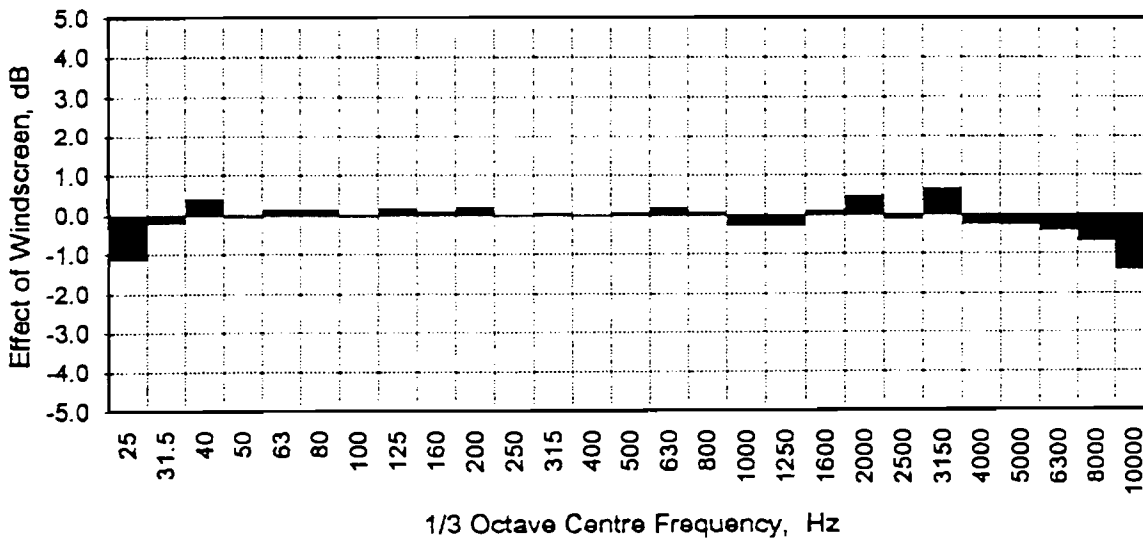

Outer Windscreen : Diameter 300 mm Hollow Foam Grade 30 ppi
 Inner Windscreen : B&K UA0237

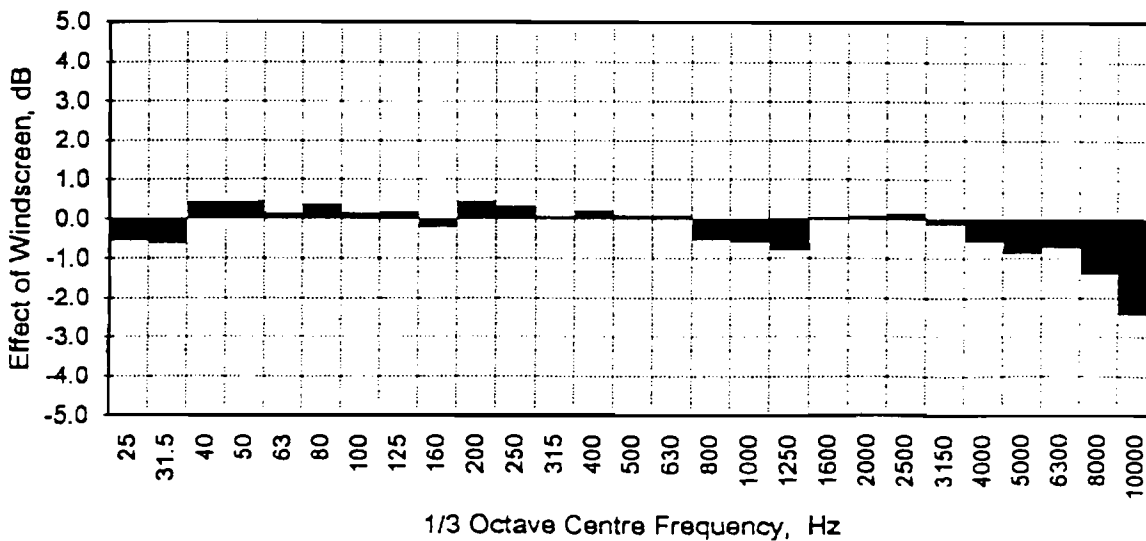

Outer Windscreen : Diameter 300 mm Hollow Foam Grade 45 ppi
 Inner Windscreen : B&K UA0237

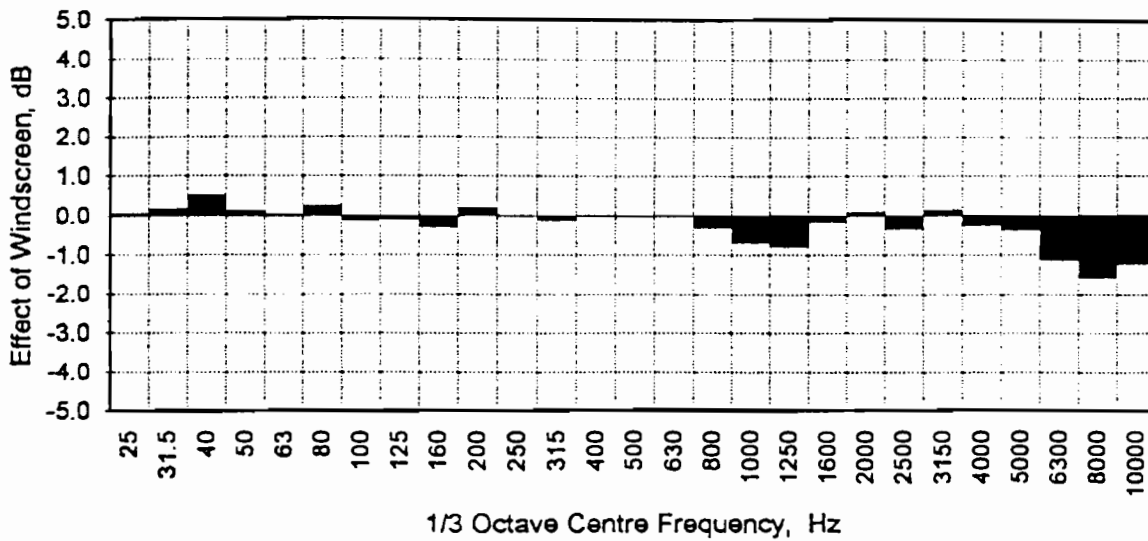

Outer Windscreen : Diameter 300 mm Hollow Foam Grade 60 ppi
 Inner Windscreen : B&K UA0237

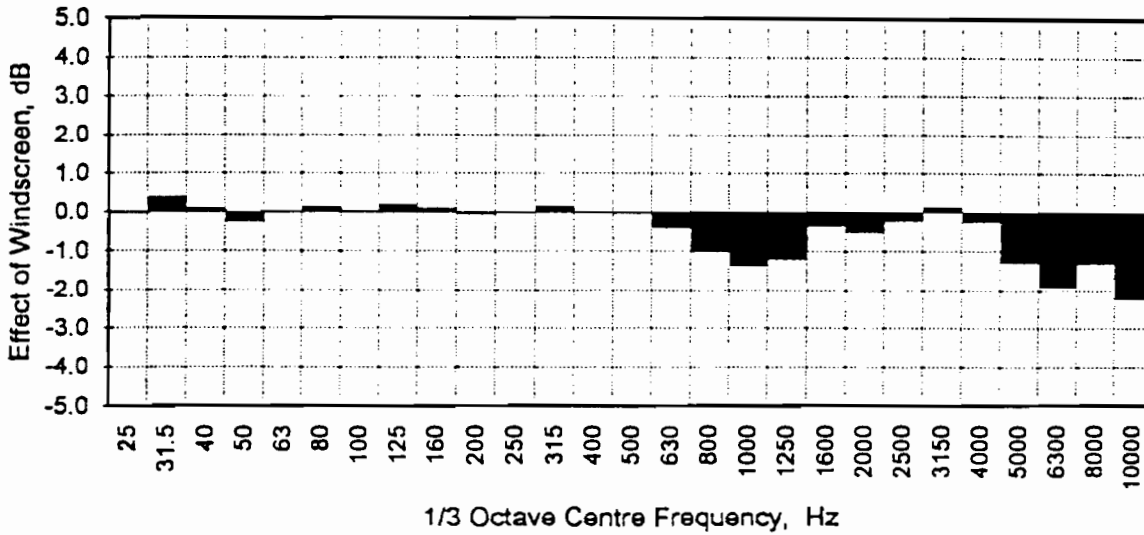

Outer Windscreen : Diameter 300 mm Hollow Foam Grade 80 ppi
 Inner Windscreen : B&K UA0237

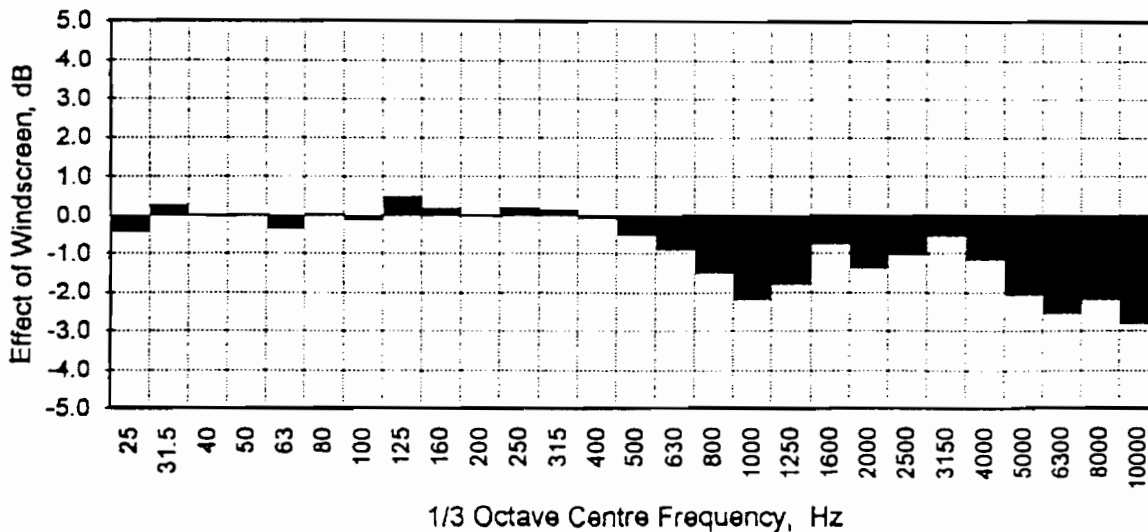

Outer Windscreen : Diameter 300 mm Hollow Foam Grade 10 ppi
 Inner Windscreen : B&K UA0570/UA0393

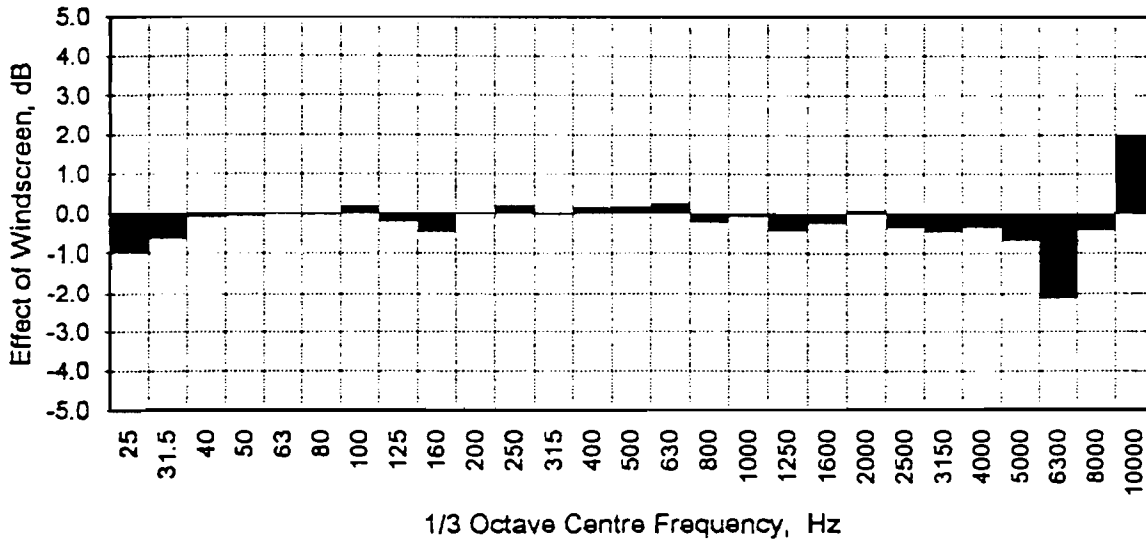

Outer Windscreen : Diameter 300 mm Hollow Foam Grade 20 ppi
 Inner Windscreen : B&K UA0570/UA0393

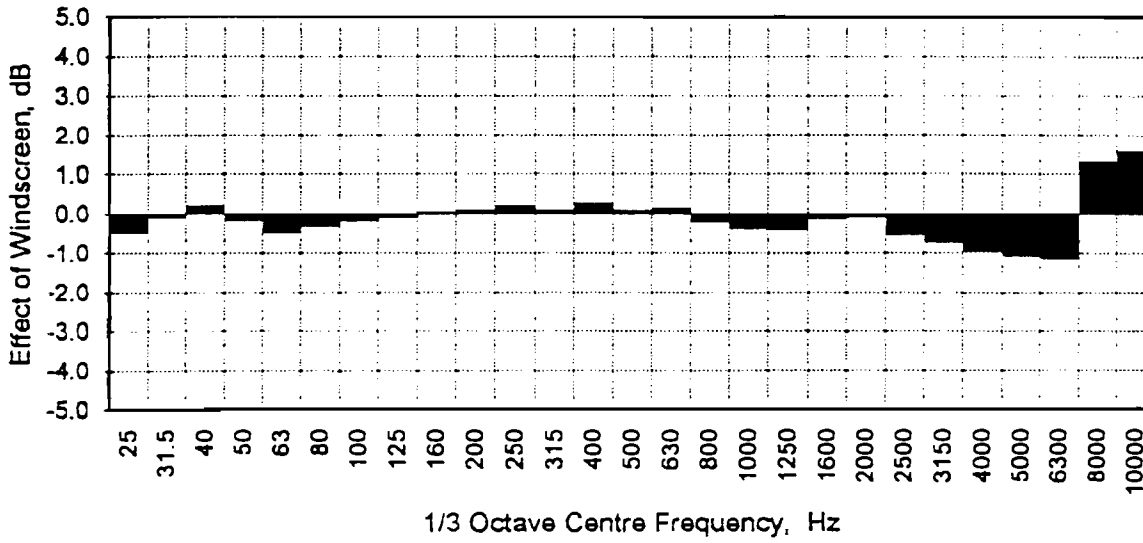

Outer Windscreen : Diameter 300 mm Hollow Foam Grade 30 ppi
 Inner Windscreen : B&K UA0570/UA0393

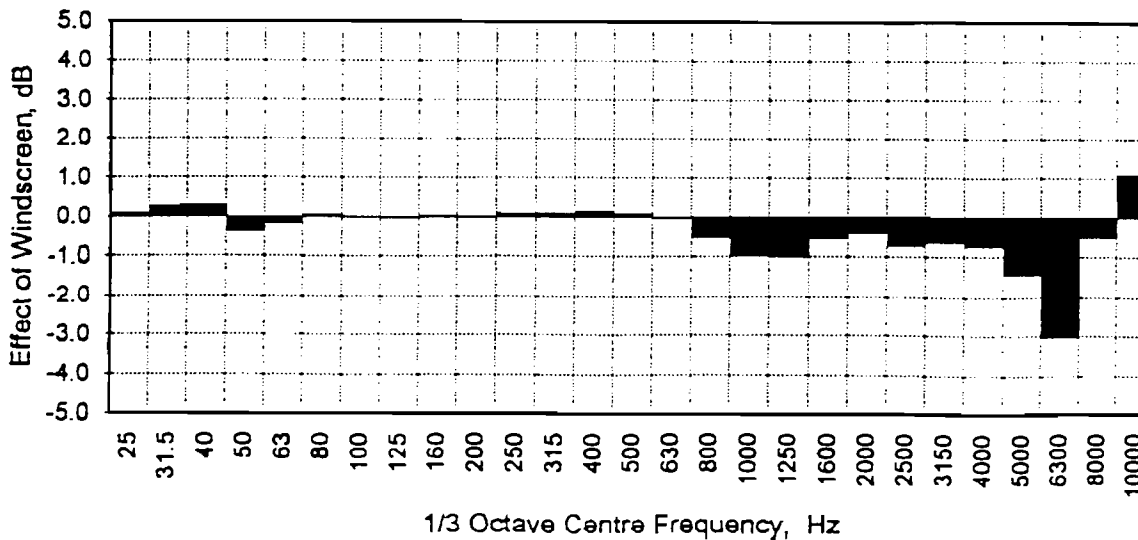

Outer Windscreen : Diameter 300 mm Hollow Foam Grade 45 ppi
 Inner Windscreen : B&K UA0570/UA0393

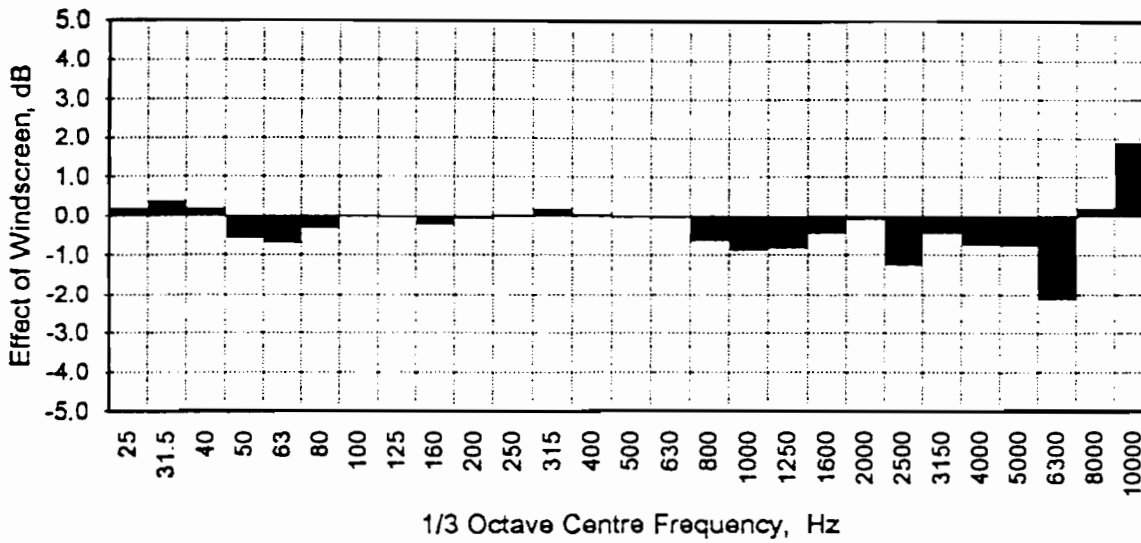

Outer Windscreen : Diameter 300 mm Hollow Foam Grade 60 ppi
 Inner Windscreen : B&K UA0570/UA0393

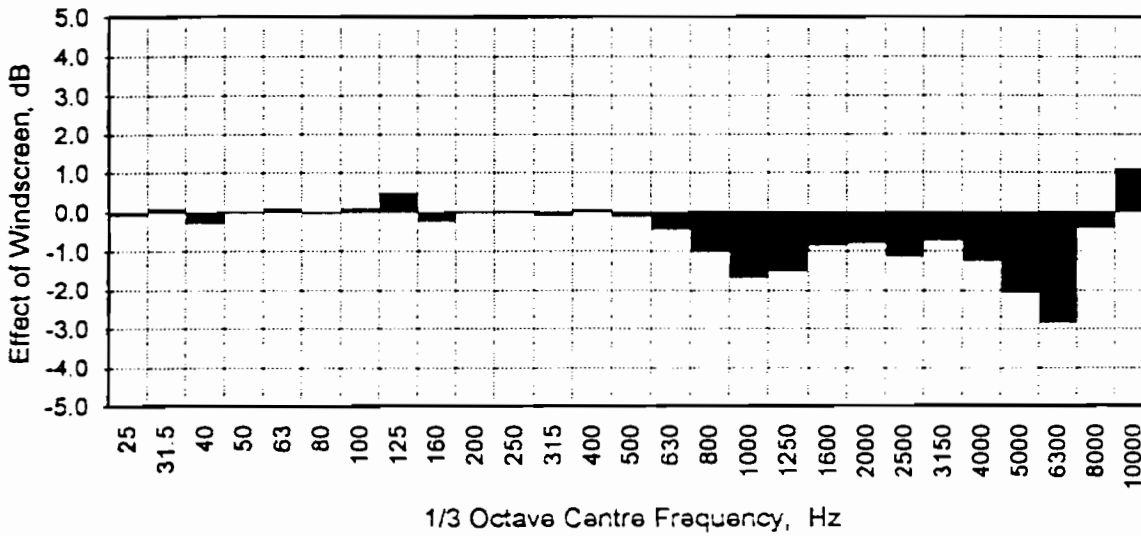

Outer Windscreen : Diameter 300 mm Hollow Foam Grade 80 ppi
 Inner Windscreen : B&K UA0570/UA0393

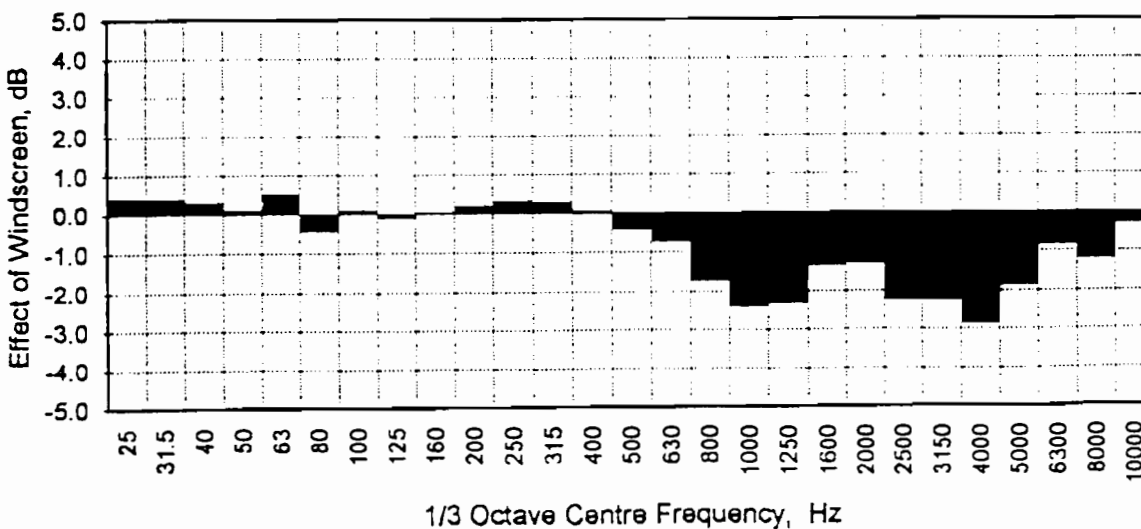

Outer Windscreen : Diameter 400 mm Hollow Foam Grade 10 ppi
Inner Windscreen : None

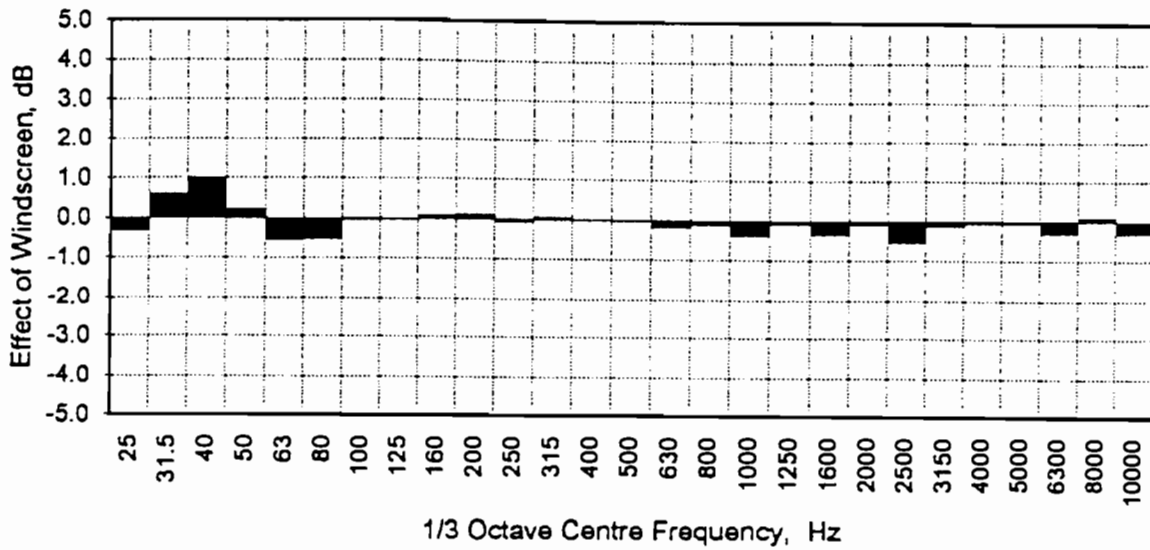

Outer Windscreen : Diameter 400 mm Hollow Foam Grade 20 ppi
Inner Windscreen : None

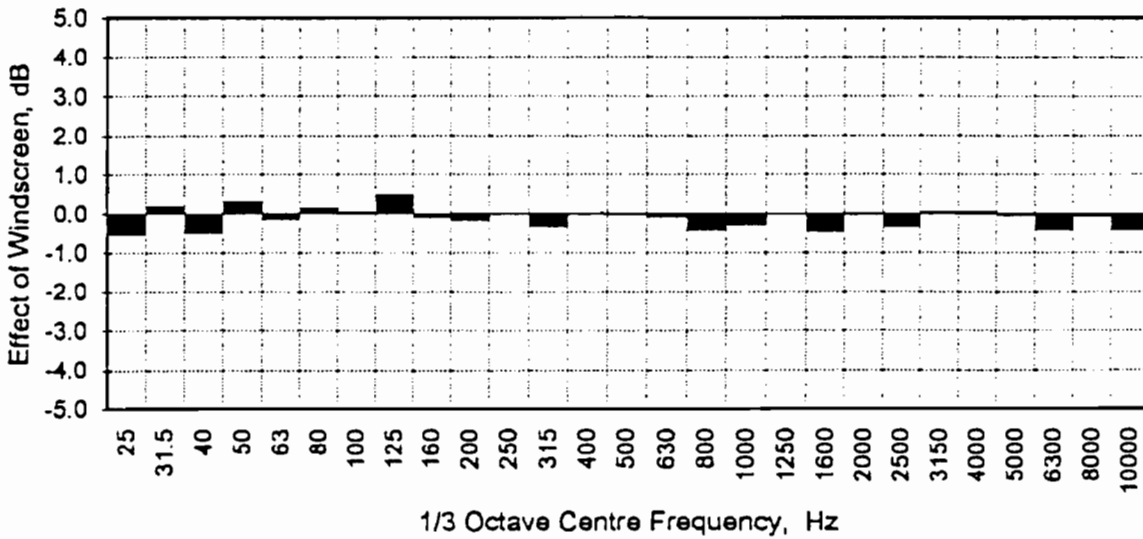

Outer Windscreen : Diameter 400 mm Hollow Foam Grade 30 ppi
Inner Windscreen : None

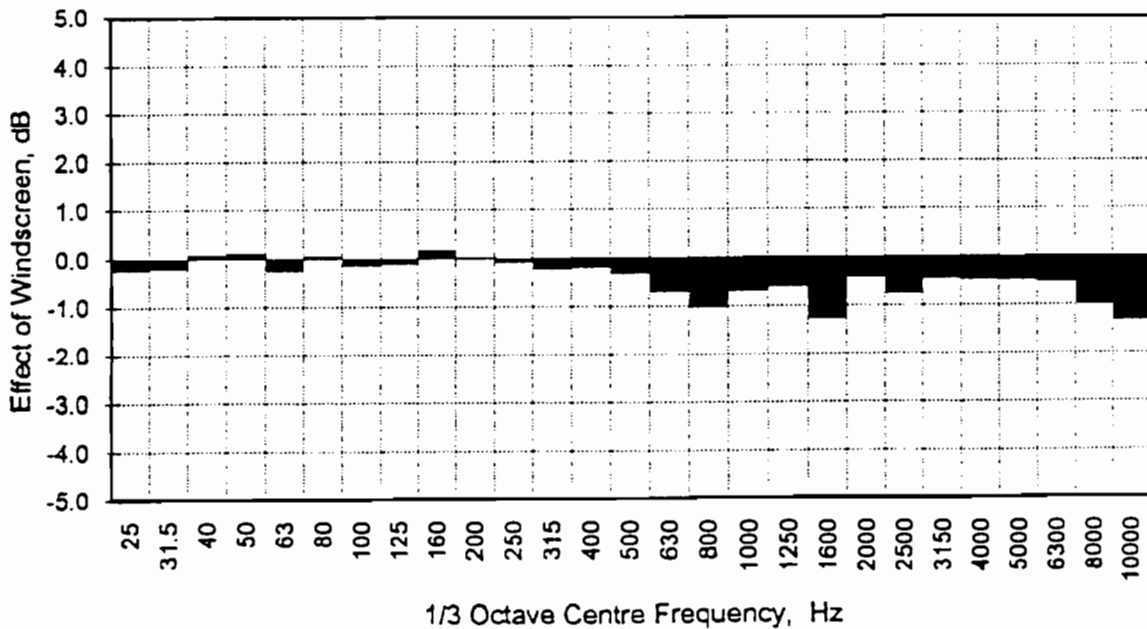

Outer Windscreen : Diameter 400 mm Hollow Foam Grade 45 ppi
 Inner Windscreen : None

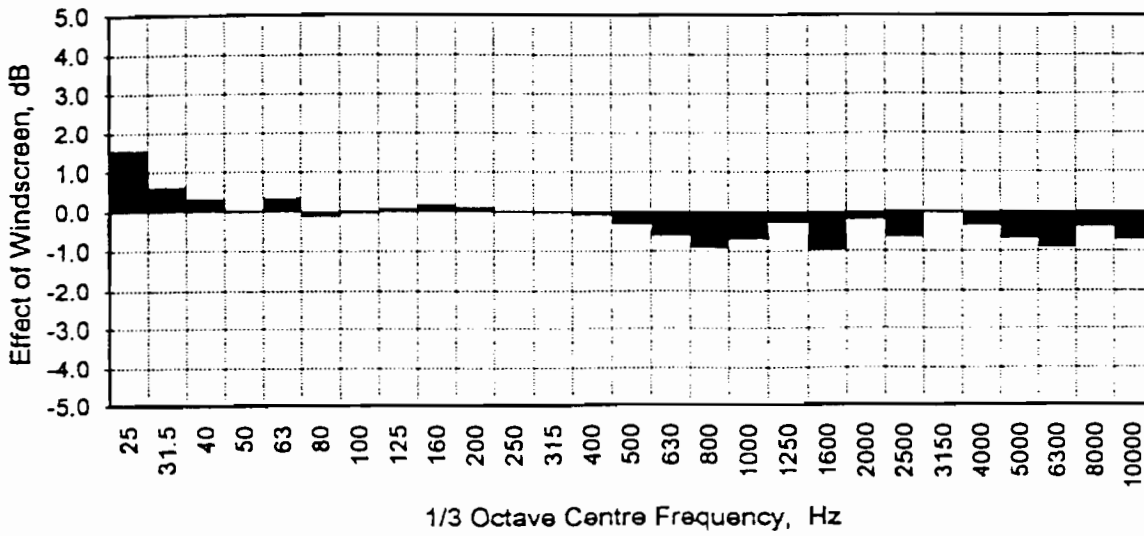

Outer Windscreen : Diameter 400 mm Hollow Foam Grade 60 ppi
 Inner Windscreen : None

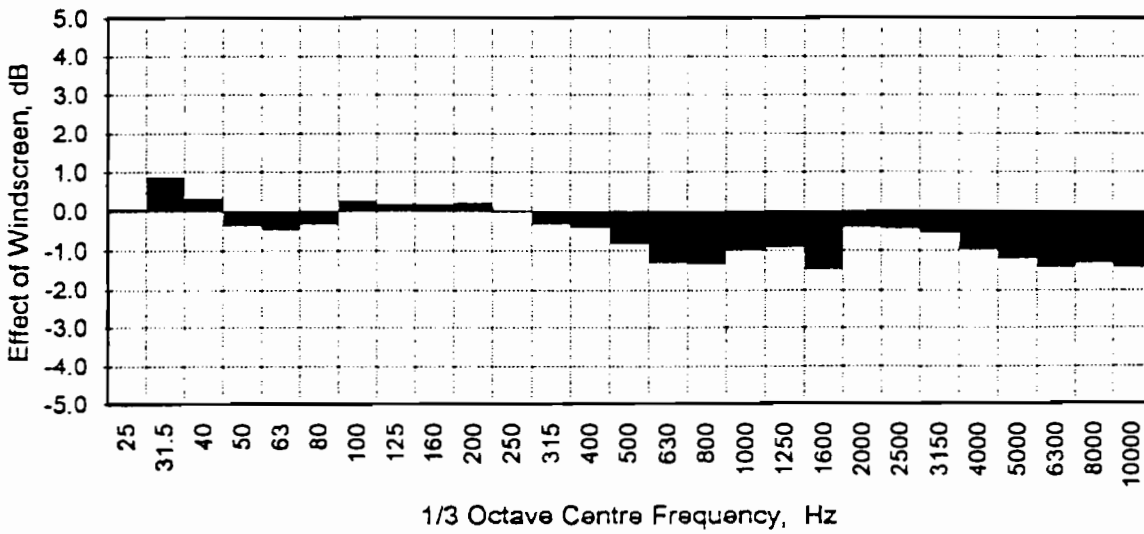

Outer Windscreen : Diameter 400 mm Hollow Foam Grade 80 ppi
 Inner Windscreen : None

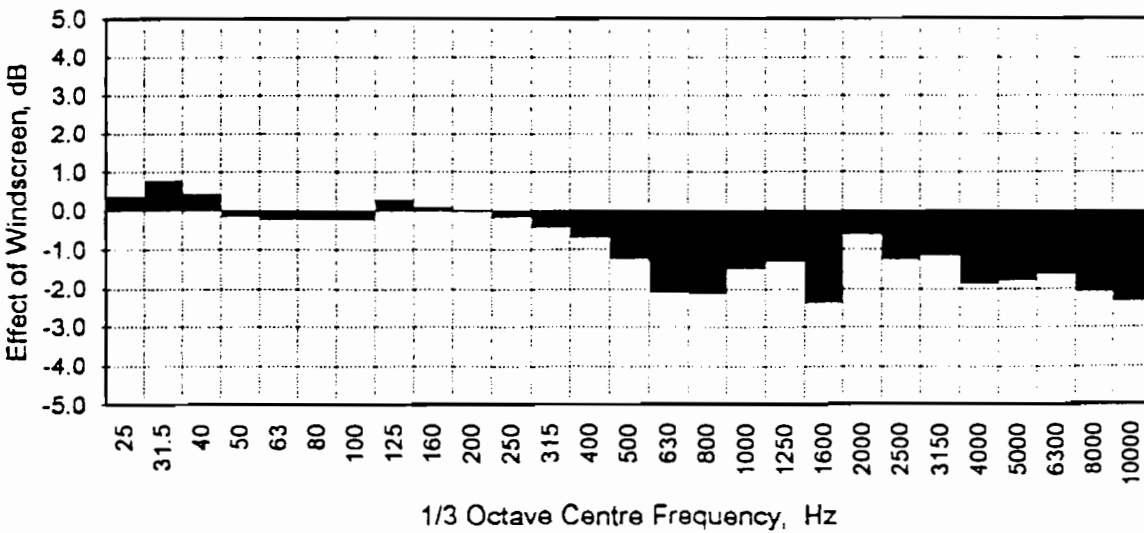

Outer Windscreen : Diameter 400 mm Hollow Foam Grade 10 ppi
 Inner Windscreen : B&K UA0237

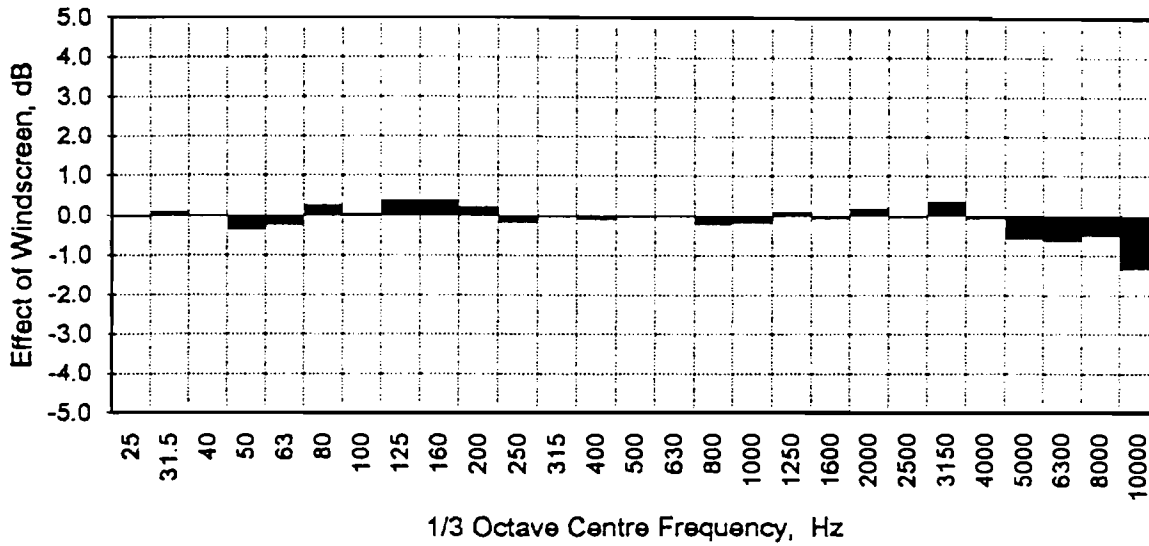

Outer Windscreen : Diameter 400 mm Hollow Foam Grade 20 ppi
 Inner Windscreen : B&K UA0237

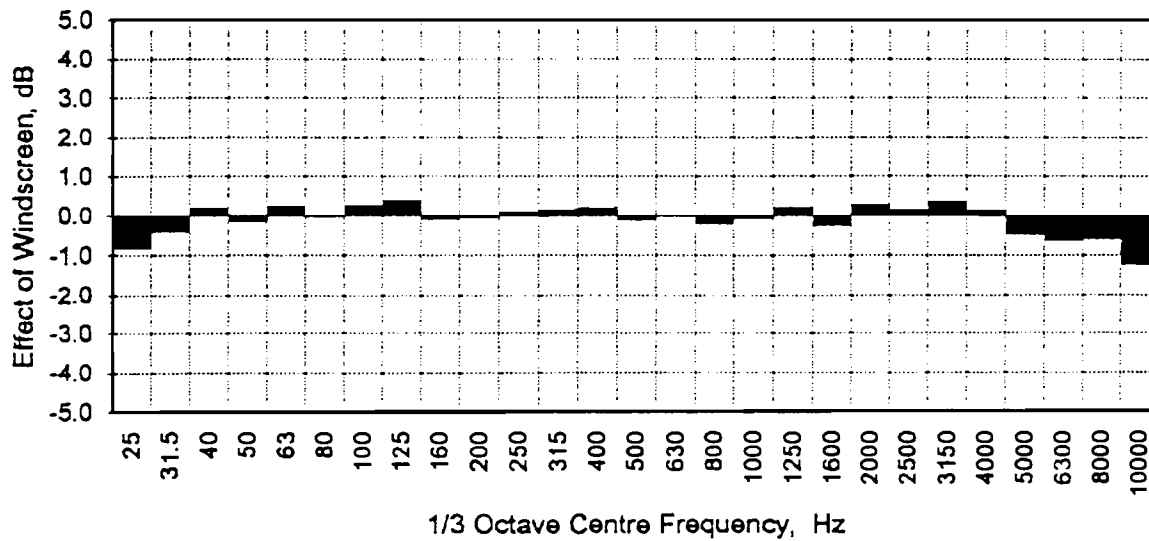

Outer Windscreen : Diameter 400 mm Hollow Foam Grade 30 ppi
 Inner Windscreen : B&K UA0237

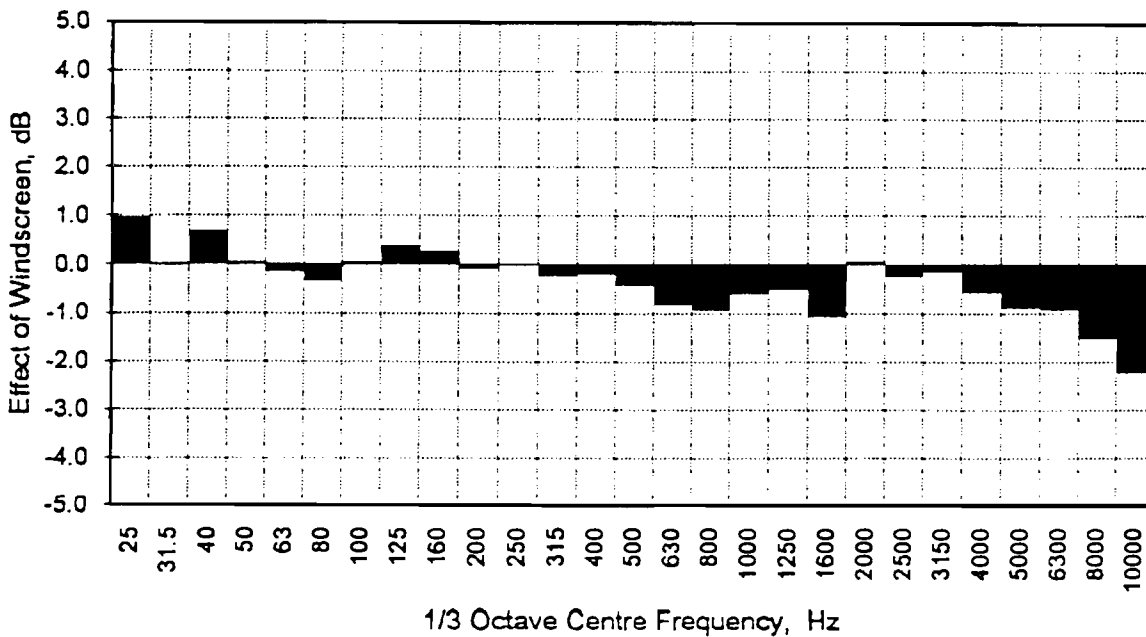

Outer Windscreen : Diameter 400 mm Hollow Foam Grade 45 ppi
 Inner Windscreen : B&K UA0237

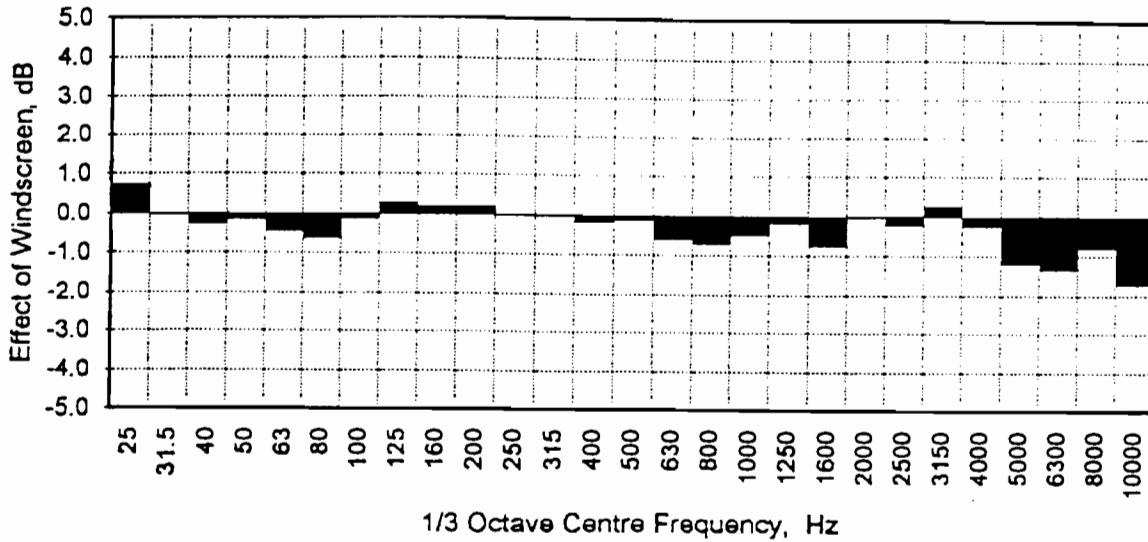

Outer Windscreen : Diameter 400 mm Hollow Foam Grade 60 ppi
 Inner Windscreen : B&K UA0237

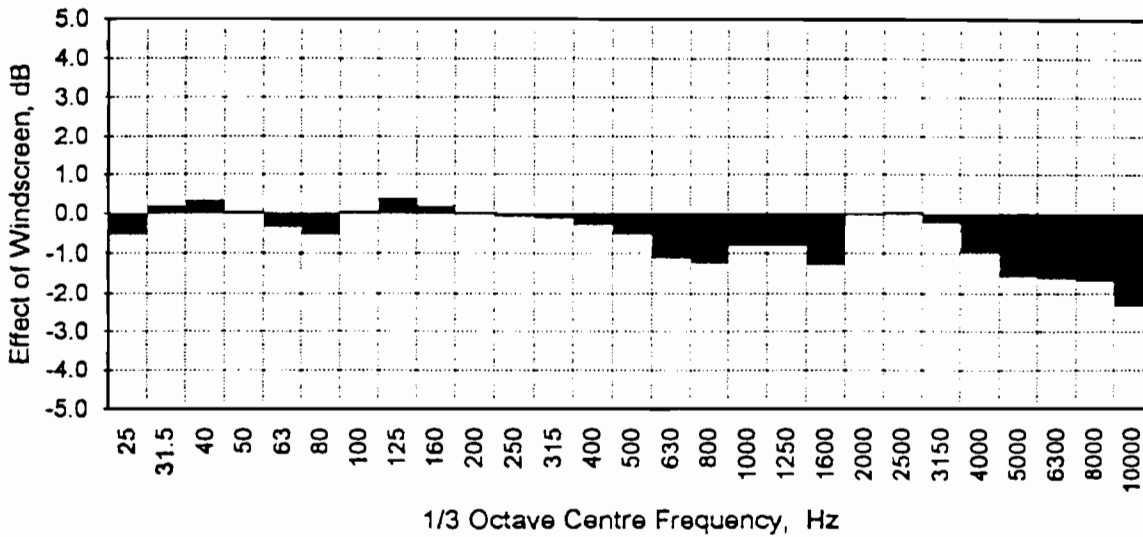

Outer Windscreen : Diameter 400 mm Hollow Foam Grade 80 ppi
 Inner Windscreen : B&K UA0237

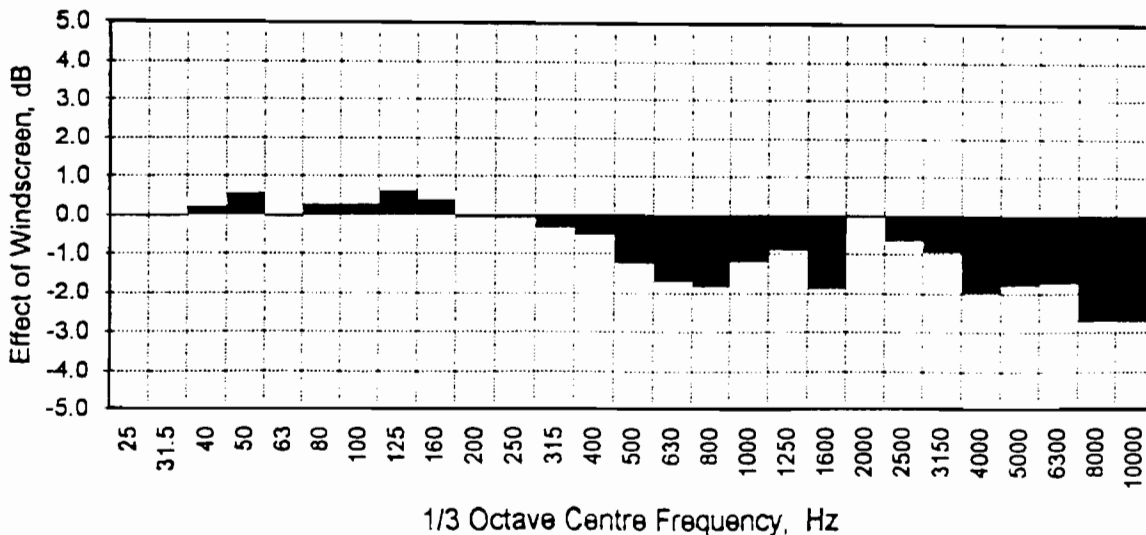

Outer Windscreen : Diameter 400 mm Hollow Foam Grade 10 ppi
 Inner Windscreen : B&K UA0570/UA0393

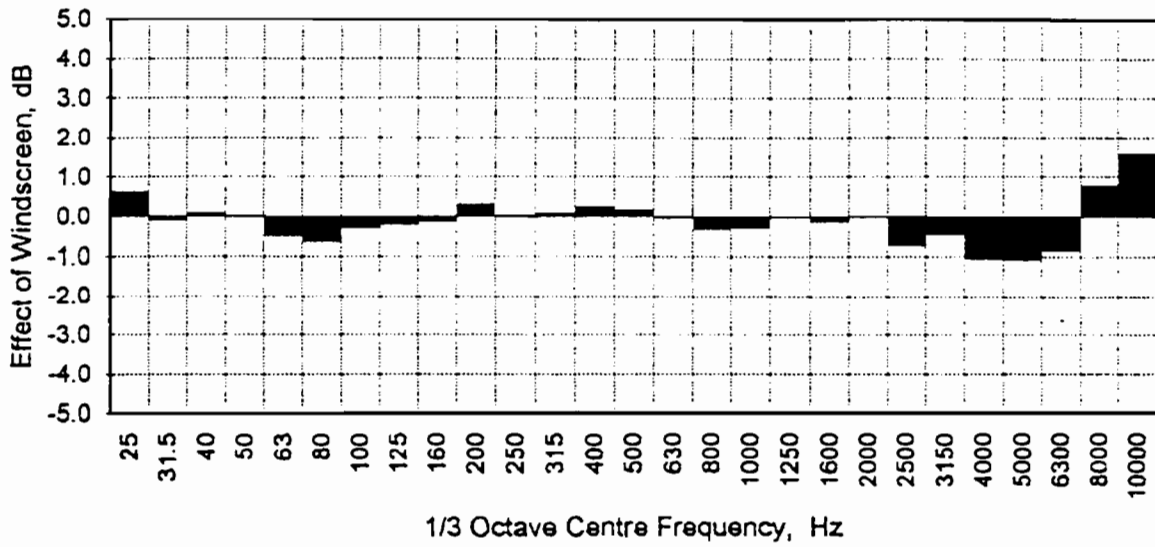

Outer Windscreen : Diameter 400 mm Hollow Foam Grade 20 ppi
 Inner Windscreen : B&K UA0570/UA0393

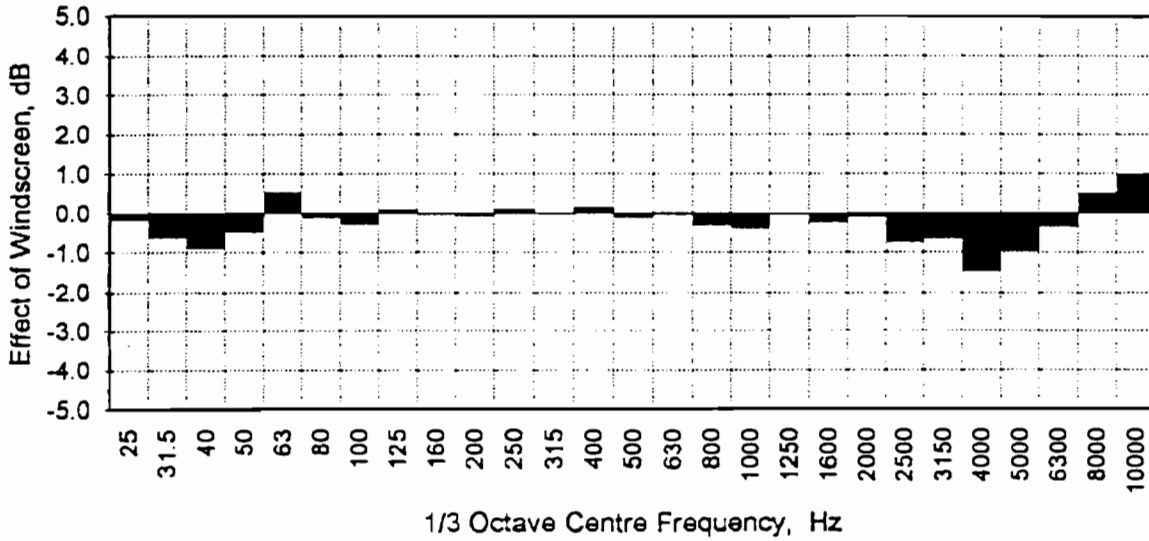

Outer Windscreen : Diameter 400 mm Hollow Foam Grade 30 ppi
 Inner Windscreen : B&K UA0570/UA0393

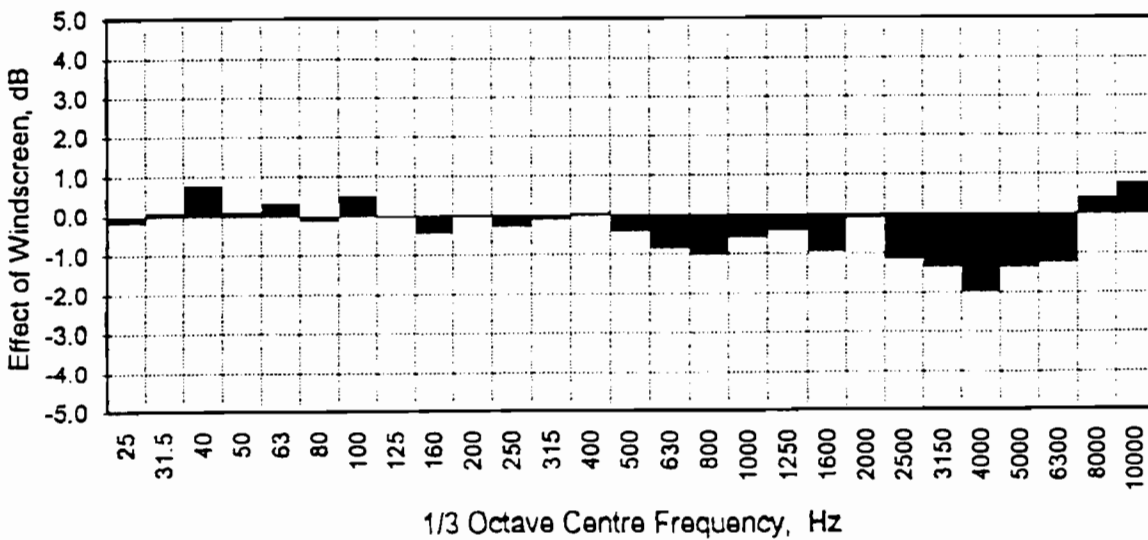

Outer Windscreen : Diameter 400 mm Hollow Foam Grade 45 ppi
 Inner Windscreen : B&K UA0570/UA0393

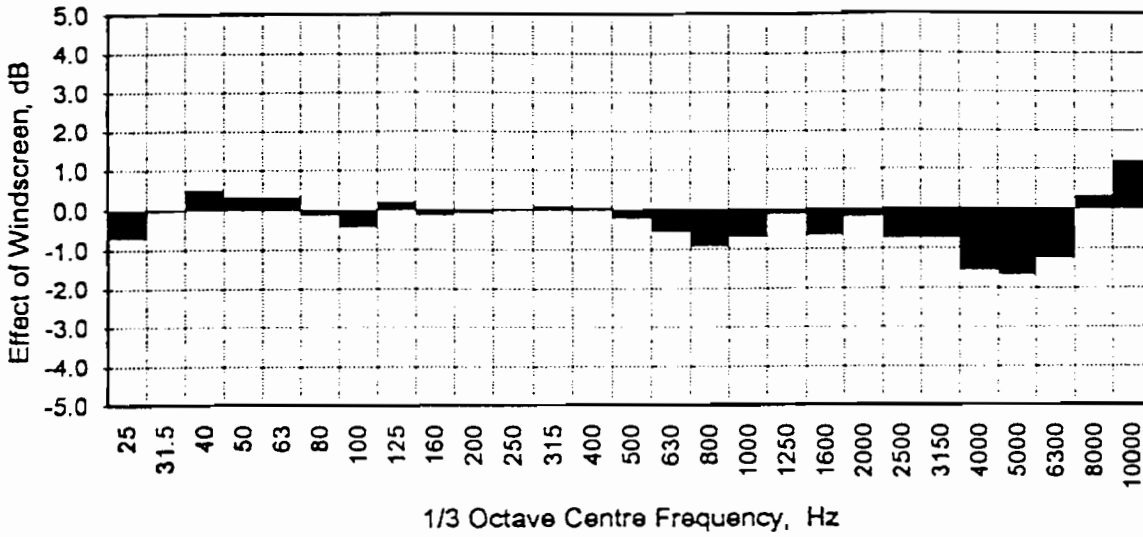

Outer Windscreen : Diameter 400 mm Hollow Foam Grade 60 ppi
 Inner Windscreen : B&K UA0570/UA0393

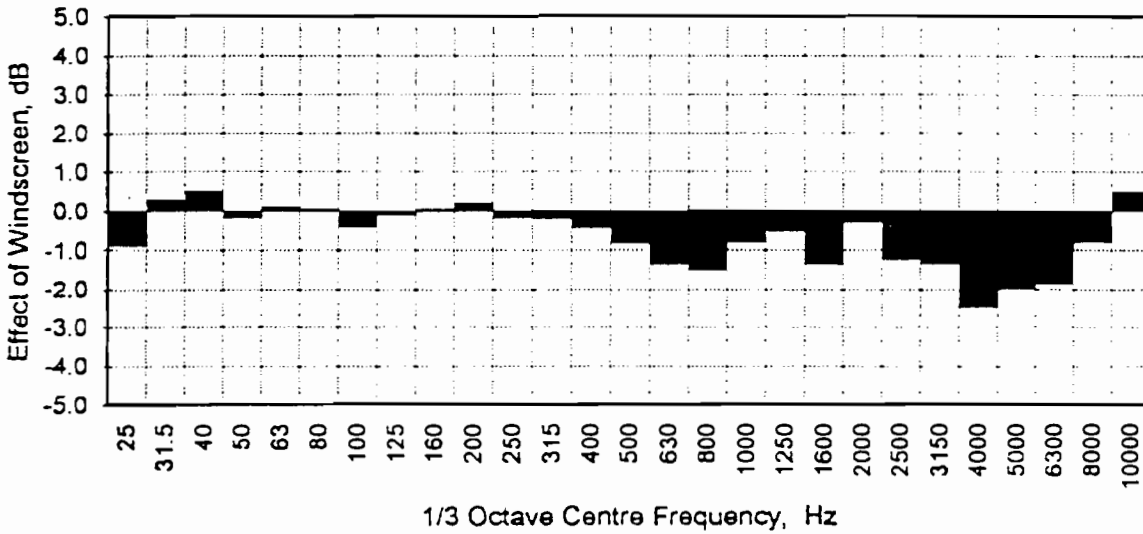

Outer Windscreen : Diameter 400 mm Hollow Foam Grade 80 ppi
 Inner Windscreen : B&K UA0570/UA0393

